

SD 700 Series

VARIABLE SPEED DRIVE

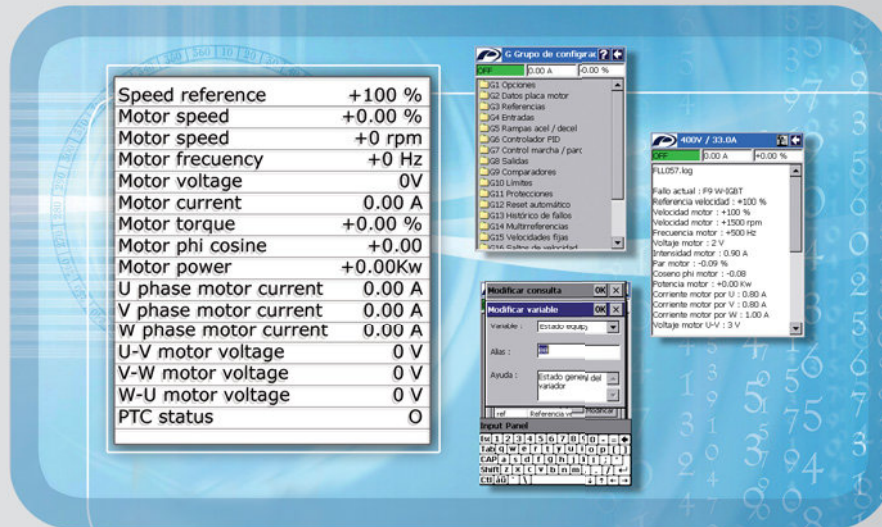
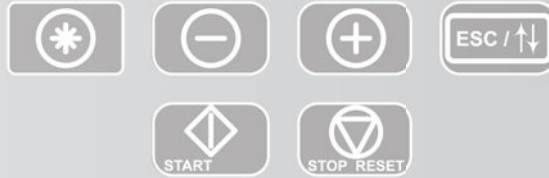

Variable Speed Drive Programming and Software Manual

SD700

Series

VARIABLE SPEED DRIVE

Variable Speed Drive

Programming and Software Manual

SD700_R2.3

Edition: September 2013

SD70MTSW01CI Rev. C

E
N
G
L
I
S
H

SAFETY SYMBOLS

Always follow safety instructions to prevent accidents and potential hazards from occurring.

**WARNING**

This symbol means improper operation may result in serious personal injury or death.

**CAUTION**

Identifies shock hazards under certain conditions. Particular attention should be given because dangerous voltage may be present. Maintenance operation should be done by qualified personnel



Identifies potential hazards under certain conditions. Read the message and follow the instructions carefully.



Identifies shock hazards under certain conditions. Particular attention should be given because dangerous voltage may be present.

Edition of September 2013

This publication could present technical imprecision or misprints. The information here included will be periodically modified and updated, and all those modifications will be incorporated in later editions. To consult the most updated information of this product you might access through our website www.power-electronics.com where the latest version of this manual can be downloaded.

Revisions

Date	Revision	Description
29 / 04 / 2010	A	First edition. SW version 2.0 (25)
31 / 03 / 2011	B	Software version updating and misprinting errors. SW Version 2.0 (26)
26 / 09 / 2013	C	SW Version 2.3

INDEX

SAFETY INSTRUCTIONS	6
1. DISPLAY UNIT AND CONTROL KEYPAD	10
1.1. Keypad Unit Description.....	10
2. STATUS MESSAGES	13
2.1. List of Status Messages.....	13
2.2. List of Warning Messages.....	14
3. VISUALIZATION AND STATUS PARAMETERS. GROUP G0	15
3.1. Parameters SV.1 – Motor Visualization.....	15
3.2. Parameters SV.2 – Drive Visualization	16
3.3. Parameters SV.3 – External Visualization.....	16
3.4. Parameters SV.4 – Internal Visualization.....	17
3.5. Parameters SV.5 – Programmable Parameters.....	17
3.6. Parameters SV.6 – Registers.....	17
4. DESCRIPTION OF PROGRAMMING PARAMETERS	18
4.1. Group 1 – G1: Options Menu	18
4.2. Group 2 – G2: Motor Nameplate Data	20
4.3. Group 3 – G3: References	21
4.4. Group 4 – G4: Inputs.....	22
4.5. Group 5 – G5: Acceleration and Deceleration Ramps	30
4.6. Group 6 – G6: PID Control.....	32
4.7. Group 7 – G7: Start / Stop Mode Configuration	33
4.8. Group 8 – G8: Outputs.....	35
4.9. Group 9 – G9: Comparators.....	40
4.10. Group 10 – G10: Limits	44
4.11. Group 11 – G11: Protections	45
4.12. Group 12 – G12: Auto Reset.....	47
4.13. Group 13 – G13: Fault History	49
4.14. Group 14 – G14: Multi-references.....	50
4.15. Group 15 – G15: Inch Speeds	50
4.16. Group 16 – G16: Skip Frequencies.....	50
4.17. Group 17 – G17: Brake.....	51
4.18. Group 18 – G18 : Encoder	51
4.19. Group 19 – G19: Fine Tuning	52
4.20. Group 20 – G20: Communication Buses.....	55
4.21. Group 21 – G21: Networks	58
5. MODBUS COMMUNICATION	61
5.1. Supported Modbus Function Codes.....	61
5.2. Addressing Modes	62
5.3. Remote Control Functions	63
5.4. Summary of Modbus Addresses	64
6. FAULT MESSAGES. DESCRIPTION AND ACTIONS	77
6.1. Description of Fault List.....	77
6.2. Procedure for Fault Solutions.....	79
7. COMMONLY USED CONFIGURATIONS	82
7.1. Start / Stop Commands and Speed Reference by Keypad	82
7.2. Start / Stop Commands by Terminals and Speed Reference by Analogue Input.....	84
7.3. Start / Stop Commands by Terminals and Speed Reference by Motorized Potentiometer.....	83
7.4. Start / Stop Commands by Terminals and Seven Speed References Selectable by Digital Inputs.....	85
8. CONFIGURATION REGISTER	87

SAFETY INSTRUCTIONS

IMPORTANT!

- Read this manual carefully to maximise the performance of this product and to ensure its safe use.
- In this manual, safety messages are classified as follows:



WARNING

Do not remove the cover while the power is applied or the unit is in operation.
Otherwise electric shock could occur.

Do not run the drive with the front cover removed.
Otherwise you may get an electric shock due to the high voltage terminals or exposure of charged capacitors.

Do not remove the cover except for periodic inspections or wiring, even if the input power is not applied. Otherwise you may access the charged circuits and get an electric shock.

Wiring and periodic inspections should be performed at least 10 minutes after disconnecting the input power and after checking the DC Link voltage is discharged with a meter (below 30VDC).
Otherwise you may get an electric shock.

Operate the switches with dry hands.
Otherwise you may get an electric shock.

Do not use cables with damaged insulation.
Otherwise you may get an electric shock.

Do not subject the cables to abrasions, excessive stress, heavy loads or pinching.
Otherwise, you may get an electric shock.



CAUTION

Install the drive on a non-flammable surface. Do not place flammable material nearby.
Otherwise fire could occur.

Disconnect the input power if the drive gets damaged.
Otherwise it could result in a secondary accident or fire.

After the input power is applied or removed, the drive will remain hot for a couple of minutes.
Touching hot parts may result in skin burns.

Do not apply power to a damaged drive or to a drive with parts missing even if the installation is complete.
Otherwise you may get an electric shock.

Do not allow lint, paper, wood chips, dust, metallic chips or other foreign matter into the drive.
Otherwise fire or accident could occur.



WARNINGS

RECEPTION

- The SD700 is carefully tested and perfectly packed before leaving the factory.
 - In the event of transport damage, please ensure that you notify the transport agency and POWER ELECTRONICS: 902 40 20 70 (International +34 96 136 65 57) or your nearest agent, within 24hrs from receipt of the goods.
-

UNPACKING

- Make sure model and serial number of the variable speed drive are the same on the box, delivery note and unit.
 - Each variable speed drive is supplied with a SD700 technical manual.
-

RECYCLING

- Packing of the equipments should be recycled. For this, it is necessary to separate different materials included (plastic, paper, cardboard, wood, ...) and deposit them on proper banks.
 - Waste products of electric and electronic devices should be selectively collected for their correct environmental management.
-

EMC

- This type of PDS (Power Device System) is not intended to be used on a low-voltage public network which supplies domestic premises.
 - Radio frequency interference is expected if used on such a network.
-

SAFETY

- Before operating the drive, read this manual thoroughly to gain an understanding of the unit. If any doubt exists then please contact POWER ELECTRONICS, (902 40 20 70 / +34 96 136 65 57) or your nearest agent.
 - Wear safety glasses when operating the drive with power applied and the front cover is removed.
 - Handle the drive with care according to its weight.
 - Install the drive according to the instructions within this manual.
 - Do not place heavy objects on the drive.
 - Ensure that the mounting orientation is correct.
 - Do not drop the drive or subject it to impact.
 - The SD700 drives contain static sensitive printed circuit boards. Use static safety procedures when handling these boards.
 - Avoid installing the drive in conditions that differ from those described in the *Technical Characteristics* section.
-

CONNECTION PRECAUTIONS

- To ensure correct operation of the drive it is recommended to use a SCREENED CABLE for the control wiring.
 - For EMERGENCY STOP, make sure supply circuitry is open.
 - Do not disconnect motor cables if input power supply remains connected. The internal circuits of the SD700 Series will be damaged if the incoming power is connected and applied to output terminals (U, V, W).
 - It is not recommended to use a 3-wire cable for long distances. Due to increased leakage capacitance between conductors, over-current protective feature may not operate correctly.
 - Do not use power factor correction capacitors, surge suppressors, or RFI filters on the output side of the drive. Doing so may damage these components.
 - Always check whether the DC Link LED is OFF before wiring terminals. The capacitors may hold high-voltage even after the input power is disconnected. Use caution to prevent the possibility of personal injury.
-

TRIAL RUN

- Verify all parameters before operating the drive. Alteration of parameters may be required depending on application and load.
 - Always apply voltage and current signals to each terminal that are within levels indicated within this manual. Otherwise, damage to the drive may result.
-

OPERATION PRECAUTIONS

- When the Auto Restart function is enabled, keep clear of driven equipment, as the motor will restart suddenly after a fault is reset.
 - The “STOP / RESET” key on the keypad is active only if the appropriate function setting has been made. For this reason, install a separate EMERGENCY STOP push button that can be operated at the equipment.
 - If a fault reset is made with the reference signal still present then a restart will occur. Verify that it is permissible for this to happen, otherwise an accident may occur.
 - Do not modify or alter anything within the drive.
 - Before programming or operating the SD700 Series, initialise all parameters back to factory default values.
-

EARTH CONNECTION

- The drive is a high frequency switching device and leakage current may flow. Ground the drive to avoid electrical shock. Use caution to prevent the possibility of personal injury.
 - Connect only to the dedicated ground terminal of the drive. Do not use the case or the chassis screw for grounding.
 - When installing, grounding wire should be connected first and removed last.
 - The earth cable must have a minimal cross sectional area that meets local country electrical regulations.
 - Motor ground must be connected to the drive ground terminal and not to the installation’s ground. We recommend that the section of the ground connection cable should be equal or higher than the active conductor.
 - Installation ground must be connected to the drive ground terminal.
-

1. DISPLAY UNIT AND CONTROL KEYPAD

1.1. Keypad Unit Description

The display of the SD700 is removable for remote installation, as the illustration shows. There are three leds on the display which indicate the drive operational status, one LCD screen with 4 lines of 16 characters each and keys for control and parameter setting.

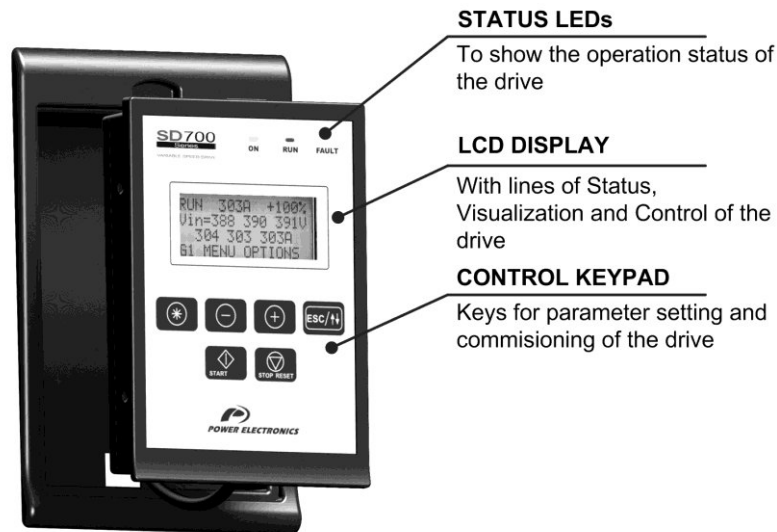

SD70ITC0103AI

Figure 1.1 Display Unit and Keypad

1.1.1. LEDs for Status Indication

Leds offer an easy method of identifying if the SD700 is powered up, if the drive is supplying output voltage, or if the drive has tripped.

- **Led ON:** Yellow colour. When it is lit, indicates equipment is powered up. When it is blinking, indicates the drive gets any warning.
- **Led RUN:** Green colour. When it is lit, indicates the motor is powered by the SD700.
- **Led FAULT:** Red colour. When it is blinking, indicates the equipment is in fault status.



SD70ITC0107AI

Figure 1.2 Status Visualization

1.1.2. Alphanumeric LCD Display

SD700 display has a LCD screen of four lines with sixteen characters each (16x4). Each line has different functions.

- **Status Line:** It is the top line. It is always present and shows the SD700 status (STR – Start, STP – Stop, etc...). It also shows the output current and the motor speed. It is not configurable by the user.

- **Visualization Line 1:** It is the second line of the screen. It is always present and allows the selection of variables from the visualization menu. It is configurable by the user.

- **Visualization Line 2:** It is the third line of the screen. It is always present and allows the selection of variables from the visualization menu. It is configurable by the user.

- **Programming Line:** It is the fourth line. It is used to display and / or set different parameters within the SD700.



SD700ITC0108AI

Figure 1.3 Detail of Display Lines

1.1.3. Control Keys

Function keys have multiple uses and can be operated individually or in combination with other keys:



It allows access to different parameters groups and sub-groups; it displays code explanations and allows adjustment of parameter values in combination with other keys. If a group has no sub-groups, it allows direct access to the parameters of the group.

To modify numeric parameters:



Simultaneously pushed, the value will increase.



Simultaneously pushed, the value will decrease.

To modify parameters of numbered options:



Pushing this key, the extended explanation will appear.



Simultaneously pushed will ascend the user through the varying options.



Simultaneously pushed will descend the user through the varying options.



It allows upward movement through the parameters groups and allows navigation for different parameters within a parameter group. It also allows the increase of parameters value.



It allows downward movement through the parameters groups and allows navigation for different parameters within a parameter group. It also allows the decrease of parameters value.



When pushed for 2 seconds (approx.) it allows navigation between the programming line and visualisation lines available to the user. It also offers the possibility of escaping back to the previous sub-group or group.



To start the drive from the keypad when the control has been set as local control (check drive configuration).



To stop the drive from the keypad when the control has been set as local control. In the case of tripping this key can be used to reset the drive, if local control is enabled.

In the following figure you can see a programming example where you can observe the operation explained previously.

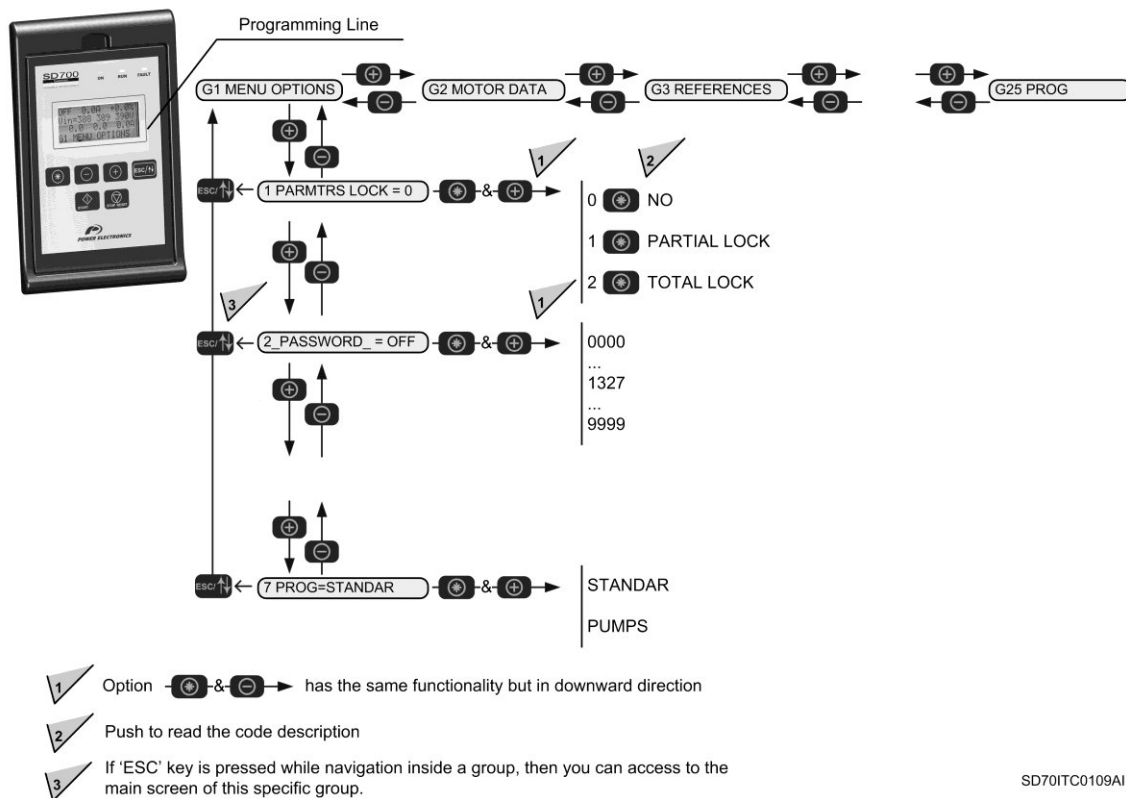

Figure 1.4 Example of parameters navigation

2. STATUS MESSAGES

The upper line of the display corresponds to the status line. In this line we can display the equipment status, motor current (A) and the motor speed (%). It is always displayed and it is not programmable by the user.

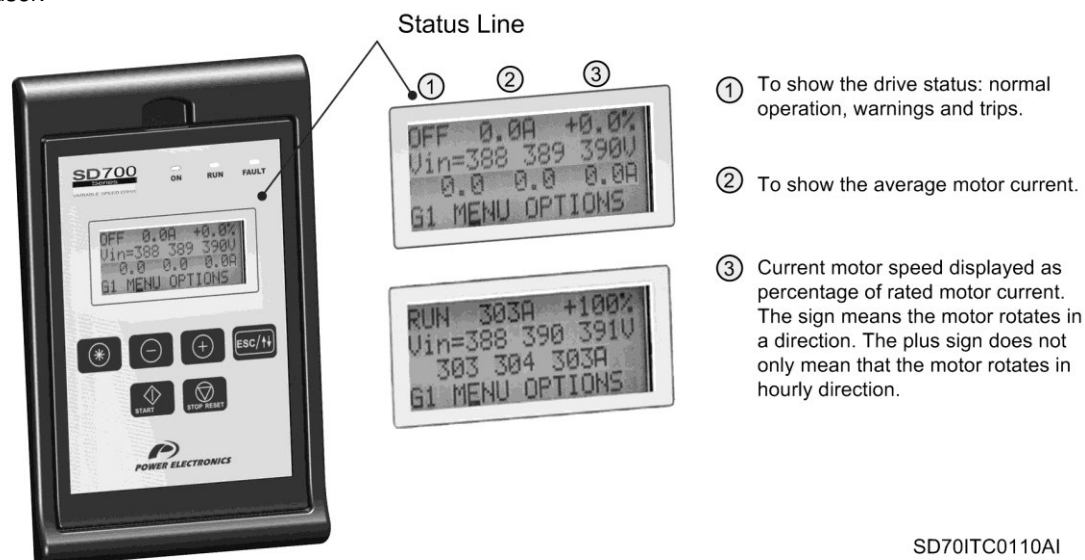



Figure 2.1 Status Line Description

Note: The user can access to the information displayed in status line via Modbus communication. See section 'Modbus Communication'.

2.1. List of Status Messages

Screen	Name	Description
OFF	Deactivated power	Drive power is deactivated.
ON	Activated power	Drive power is activated.
ACL	Accelerating	Drive is increasing the output frequency. Motor increasing in speed, it is accelerating.
RUN	Running	Drive is operating at reference speed. Operation at steady status.
DEC	Decelerating	Drive is decreasing the output frequency. Motor decreasing in speed, it is decelerating.
SPG	Stopping	Drive is decreasing the output frequency due to a stop command. Motor is stopping by ramp until zero speed is reached.
EST	Free run stop when a fault occurs	Drive is stopping by free run stop after a fault occurs (emergency stop). Motor stopping time is determined by inertia as the drive output has turned off.
SPN	Flying start	'Flying start' operation must be configured if required. The SD700 will search for the actual motor shaft speed once the drive has received a start command.
DCB	DC brake	SD700 is applying DC current injection to stop the motor.

Screen	Name	Description
TBR	DC brake ON delay	Drive is applying a delay time before DC current injection is active. When this time is elapsed, the DC brake will be active.
DLY	Start Delay Time	When a delay time has been set in order to start the equipment, after the start command has been activated, this message will be displayed until this time has elapsed.
IN1	Inch speed 1	SD700 is working according to inch speed 1 command and 'Start + Inch speed 1' mode is active. When operated in this mode the "Start + Inch speed 1" command is dominant over other inputs programmed for "Start" functionality. Therefore if one input is configured as 'Start' and it is deactivated; in spite of this deactivated input, the drive will start when 'Start + Inch speed 1' command is received. This is also valid for Inch speed 2 and 3.
IN2	Inch speed 2	SD700 is working according to inch speed 2 command. 'Start + Inch speed 2' mode is active.
IN3	Inch speed 3	SD700 is working according to inch speed 3 command. 'Start + Inch speed 3' mode is active.
HEA	Non condensing current is activated	SD700 is injecting DC current to prevent moisture condensing within the motor.  CAUTION: Although the motor is not running there is dangerous voltage. Run Led will be lit during this process. Be careful to avoid damages and personal injury.

2.2. List of Warning Messages

Screen	Name	Description
MOL	Motor overload	This message will appear when motor thermal model is increasing the estimated motor temperature.
MOC	Motor over-current	Motor current is higher than the rated current value.
DOC	Drive over-current	This message will appear if the output current is higher than 125% of the nominal current.
ILT	Current limitation	Current limit algorithm has been activated.
TLT	Torque limitation	Torque limit algorithm has been activated.
VLT	Voltage limitation	A high DC Link voltage level has been detected and the voltage limit control algorithm has been activated to protect the drive.
ACO	Asymmetric current	Asymmetry in output currents of the drive has been detected.
AVO	Output voltage imbalance	Asymmetry in output voltage of the drive has been detected.
AVI	Input voltage imbalance	Asymmetry in input voltage of the drive has been detected.
OVV	High input voltage	Input voltage of the equipment is reaching a dangerous level. The value is above the set value (protections settings).
UNV	Low input voltage	Input voltage of the equipment is reaching a dangerous level. The value is below the set value (protections settings).
S1L	Speed limit 1 reached	Motor speed has reached speed limit 1.
S2L	Speed limit 2 reached	Motor speed has reached speed limit 2.

3. VISUALISATION AND STATUS PARAMETERS. GROUP G0

These parameters constantly indicate the input signal status and dynamic parameter status of the SD700. Visualization lines are the second and the third lines. The user can select the parameter to be displayed in each line from the different visualization options.

To select a display parameter you should move to the cursor to the second or third line. For this, you need to press **ESC / ↑ ↓** key for approx two seconds. The cursor moves from one line to the next. Once located on the second or third line you can navigate like the programming line (line 4) and select the desired parameter to be displayed. Once selected these parameters are saved into memory. These parameters are then displayed on lines 2 and 3 whenever the drive is powered up. Thanks to these lines user can display desired parameters and obtain additional information easily.

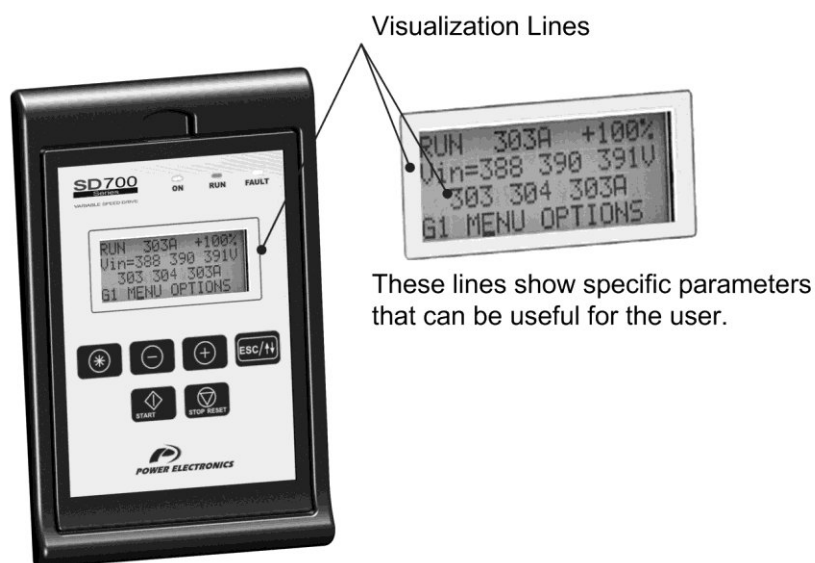

SD70ITC0111A1

Figure 3.1 Visualization Lines Description

3.1. Parameters SV.1 – Motor Visualisation

Screen	Units	Description
Sp Ref = +000%	% motor speed	It shows the present reference value of speed which is applied to the motor.
Tq Ref = 0.0%	%motor torque	It shows the present reference value of torque which is applied to the motor.
Mtr Speed = +0rpm	rpm	It shows the motor speed in revs per minute.
Mtr Sp = +0.0%	%	It shows the motor speed in %. It corresponds with the third field of the status line → OFF 0.0A +0.0%
Mtr Freq = +0.0Hz	Hz	It shows the frequency being applied to the motor.
Mtr Vout = 0V	V	It shows the present voltage applied to the motor.
Mtr Iout = 0.0A	A	It shows the present current flowing to the motor. It corresponds with the second field of the status line → OFF 0.0A +0.0%
Mtr Torqe = 0.0%	% motor torque	It shows the present torque applied to the motor.
Mtr Pfactr = 0.0	-	It shows the power factor of the motor.
Mtr Pwr = +0.0kW	kW	It shows the instantaneous power consumption of the motor.
0.0A 0.0A 0.0A	A	It shows the instantaneous current of each phase of the motor (U, V and W).
Vmt= 0 0 0V	V	It shows the instantaneous voltage applied to the motor terminals.
PTC Motor = 0	-	It shows if the motor PTC (temperature sensor) is connected. X: PTC Connected. 0: PTC Not Connected.
Motor Temp = 0.0%	% Motor heat	It shows the estimated motor temperature. A level of 110% will cause F25 trip (motor overload).
Enco. Pulso =0	pulses	It shows the encoder pulses.
Clsped = 0 rpm	rpm	Real speed measured by the encoder.

3.2. Parameters SV.2 – Drive Visualisation

Screen	Units	Description
390 390 390V	V	It shows the input instantaneous voltage applied to the drive (RS, ST, RT).
Inp Vol = 390V	V	It shows the average input voltage to the drive.
50.0 50.0 50.0Hz	Hz	It shows the frequency of the input voltage to the drive.
Bus vol = 540V	VDC	It shows DC Link voltage of the drive.
IGBT Temp =+23°C	°C	It shows the temperature measured at the power stage of the drive output.
Drive T. =+26°C	°C	It shows the temperature measured inside the electronics chamber of the drive.

3.3. Parameters SV.3 – Visualisation

Screen	Units	Description																							
ANLG IN1 = +0.0V	V or mA	It shows the value of Analogue Input 1.																							
AIN1 Refr = +0.00%	% bottom scale AI1	It shows the value or the PID reference proportional to Analogue Input 1 in percentage.																							
AIN1 S = +0.001/s	Engineering units	It shows the value of sensor 1 associated to the Analogue Input 1.																							
ANLG IN2 = +0.0V	V or mA	It shows the value of the Analogue Input 2.																							
AIN2 Refr = +0.00%	% bottom scale AI2	It shows the value or the PID reference proportional to the Analogue Input 2 signal.																							
AIN 2 S = +0.00Bar	Engineering units	It shows the value of sensor 2 associated to the Analogue Input 2.																							
ANL OUT1 = +4.0mA	V or mA	It shows the value of Analogue Output 1.																							
AO1 Refer = +0.0%	% associated magnitude	It shows the magnitude value associated to the Analogue Output 1 (speed, current ...).																							
ANL OUT2 = +4.0mA	V or mA	It shows the value of Analogue Output 2.																							
AO2 Refer = +0.0%	% associated magnitude	It shows the magnitude value associated to the Analogue Output 2 (speed, current ...).																							
DI= 000000 0	-	It shows whether the Digital Inputs are activated or not, from DI1 to DI6. The final is another input which shows the status of the motor PTC signal. X: Active. 0: Not Active.																							
Relays 1-3: X0X	-	It shows whether the output relays are activated or not. X: Active. 0: Not Active.																							
M SPD= +0.000m/s	Depending on config.	It shows the speed of the motor in engineering units. Pressing * key you can access to the following sub-parameters of configuration: <table border="1" style="margin-left: 20px;"> <thead> <tr> <th>Screen</th> <th>Range</th> <th>Description</th> </tr> </thead> <tbody> <tr> <td>Scale ftr=1</td> <td>0.001 - 10</td> <td>To set the ratio factor between motor speed and machine speed.</td> </tr> <tr> <td>Units Ma=m/s</td> <td>m/s m/m cm/s cm/m v/s v/m</td> <td>It allows selection of the units to be displayed <table border="1" style="margin-left: 20px;"> <thead> <tr> <th>Units</th> <th>Description</th> </tr> </thead> <tbody> <tr> <td>m/s</td> <td>Meters / second</td> </tr> <tr> <td>m/m</td> <td>Meters / minute</td> </tr> <tr> <td>cm/s</td> <td>Centimetres / second</td> </tr> <tr> <td>cm/m</td> <td>Centimetres / minute</td> </tr> <tr> <td>v/s</td> <td>Turns / second</td> </tr> <tr> <td>v/m</td> <td>Turns / minute</td> </tr> </tbody> </table> </td> </tr> </tbody> </table> <p>Note: They both are settable during run.</p>	Screen	Range	Description	Scale ftr=1	0.001 - 10	To set the ratio factor between motor speed and machine speed.	Units Ma=m/s	m/s m/m cm/s cm/m v/s v/m	It allows selection of the units to be displayed <table border="1" style="margin-left: 20px;"> <thead> <tr> <th>Units</th> <th>Description</th> </tr> </thead> <tbody> <tr> <td>m/s</td> <td>Meters / second</td> </tr> <tr> <td>m/m</td> <td>Meters / minute</td> </tr> <tr> <td>cm/s</td> <td>Centimetres / second</td> </tr> <tr> <td>cm/m</td> <td>Centimetres / minute</td> </tr> <tr> <td>v/s</td> <td>Turns / second</td> </tr> <tr> <td>v/m</td> <td>Turns / minute</td> </tr> </tbody> </table>	Units	Description	m/s	Meters / second	m/m	Meters / minute	cm/s	Centimetres / second	cm/m	Centimetres / minute	v/s	Turns / second	v/m	Turns / minute
Screen	Range	Description																							
Scale ftr=1	0.001 - 10	To set the ratio factor between motor speed and machine speed.																							
Units Ma=m/s	m/s m/m cm/s cm/m v/s v/m	It allows selection of the units to be displayed <table border="1" style="margin-left: 20px;"> <thead> <tr> <th>Units</th> <th>Description</th> </tr> </thead> <tbody> <tr> <td>m/s</td> <td>Meters / second</td> </tr> <tr> <td>m/m</td> <td>Meters / minute</td> </tr> <tr> <td>cm/s</td> <td>Centimetres / second</td> </tr> <tr> <td>cm/m</td> <td>Centimetres / minute</td> </tr> <tr> <td>v/s</td> <td>Turns / second</td> </tr> <tr> <td>v/m</td> <td>Turns / minute</td> </tr> </tbody> </table>	Units	Description	m/s	Meters / second	m/m	Meters / minute	cm/s	Centimetres / second	cm/m	Centimetres / minute	v/s	Turns / second	v/m	Turns / minute									
Units	Description																								
m/s	Meters / second																								
m/m	Meters / minute																								
cm/s	Centimetres / second																								
cm/m	Centimetres / minute																								
v/s	Turns / second																								
v/m	Turns / minute																								
Modbus Traffic:O	0 / X	"X" will be displayed if Modbus communication exists through RS232 or RS485 user port. Furthermore, "X" will blink at constant frequency while communication is active. After half second is elapsed without communication, "O" will be displayed.																							
Display_traffi = 0	-	It shows if the display is connected. <table border="1" style="margin-left: 20px;"> <thead> <tr> <th>Screen</th> <th>Description</th> </tr> </thead> <tbody> <tr> <td>0</td> <td>The display is not connected.</td> </tr> <tr> <td>1</td> <td>The display is connected.</td> </tr> </tbody> </table>	Screen	Description	0	The display is not connected.	1	The display is connected.																	
Screen	Description																								
0	The display is not connected.																								
1	The display is connected.																								

3.4. Parameters SV.4 – Internal Visualisation

Screen	Units	Description
Actual Fault = 00	-	It shows the present code fault. See fault history G13.
Drive Curr = 170A	A	It shows the drive rated current (maximum current of the equipment at 50°C).
Drive Volt = 400V	V	It shows the drive rated voltage.
S/W	-	It shows the software version installed into the equipment.
H/W y.y	-	It shows the hardware version of the equipment.
PID R% = +0.0%	% feedback range	It shows the reference value in PID mode of the equipment standard program.
PID F% = +0.0%	% AI used as feedback	It shows the feedback value in PID mode of the equipment standard program.
PID Error = +0.0%	% feedback range	It shows the error value in PID mode that means, the difference between the reference value and the real value of the system feedback signal.
Comparators: 000	-	It shows if comparators are activated or not. X: Active / 0: Not Active.
FLT.STAT.=NO FLT	NO FLT ---	It shows if the equipment is in faulty status. If the equipment is in faulty status, it shows the status of the drive before the fault is produced; when there is not fault, it shows 'NO FLT'.
Fault Diag.=N	N Y	When it is set to 'Y' (YES), the parameters of groups 'SV.1 Motor Visualization' and 'SV.2 Drive Visualization' are hold with the last values at the moment of the last fault is produced. If the user sets the parameter to 'N' (NO), or after 135 seconds are elapsed, the parameters will show the actual values again. The hold values are saved in memory until next fault will be produced, even if the input power of the drive is lost.

3.5. Parameters SV.5 – Programmable Parameters

This group is not only a display group. Some parameters such as speed, pressure and inch speeds can be adjusted in this group. These parameters are also available in their corresponding parameter groups. This is a simple way to allow user adjustment of basic parameters without entering the main programming groups.

Screen	Units	Description
Local Sp = +100%	% motor speed	It shows the speed reference value in local mode (introduced by keypad). See G3.3 parameter for additional data.
PID Local = +100%	% feedback	It allows user to select the PID reference in local mode. See G6.2 parameter for additional data.
Mref 1 = +10.0%	% motor speed	It allows user to set the speed value assigned to Multi-reference 1. See G14.1 parameter for additional data.
Mref 2 = +20.0%	% motor speed	It allows user to set the speed value assigned to Multi-reference 2. See G14.2 parameter for additional data.
Mref 3 = +30.0%	% motor speed	It allows user to set the speed value assigned to Multi-reference 3. See G14.3 parameter for additional data.
Mref 4 = +40.0%	% motor speed	It allows user to set the speed value assigned to Multi-reference 4. See G14.4 parameter for additional data.
Mref 5 = +50.0%	% motor speed	It allows user to set the speed value assigned to Multi-reference 5. See G14.5 parameter for additional data.
Mref 6 = +60.0%	% motor speed	It allows user to set the speed value assigned to Multi-reference 6. See G14.6 parameter for additional data.
Mref 7 = +70.0%	% motor speed	It allows user to set the speed value assigned to Multi-reference 7. See G14.7 parameter for additional data.
Inch Spd1 = 0.00%	% motor speed	It allows user to set the step frequency 1 value. See G15.1 for additional data.
Inch Spd2 = 0.00%	% motor speed	It allows user to set the step frequency 2 value. See G15.2 for additional data.
Inch Spd3 = 0.00%	% motor speed	It allows user to set the step frequency 3 value. See G15.1 and 2 for additional data.

3.6. Parameters SV.6 – Registers

This group includes several registers of general information about the drive use. Therefore, we can visualize a total and partial counter for running time (RUN).

Screen	Units	Description
TOT= d h	Days and Hours	It shows the total time during which the drive is running (RUN).
PAR= d h	Days and Hours	It shows the partial time during which the drive is running (RUN).
CLEAR PARTIAL=N	-	It allows resetting the counter of partial time for running status (RUN).
TOTAL ENERGY	kW to GW	Shows the drive total energy consumption.
PARTIAL ENERGY	kW to GW	Shows the drive partial energy consumption.
RSET PRTL ENRG=N	-	The user is able to reset the partial energy counter.

4. DESCRIPTION OF PROGRAMMING PARAMETERS

The different parameters of the SD700 are displayed in the alphanumeric LCD. These parameters are organized in groups (G1, G2, G3, ...). To access to the parameters or sub-groups which are in a lower level, press the ***** key. When you have accessed the desired parameter, this parameter will be shown as either a numerical value or a list of possible options.

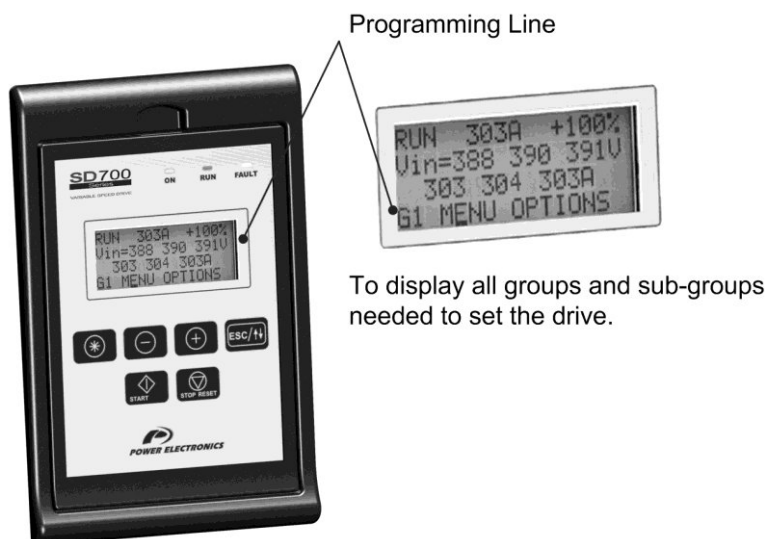

SD70ITC0112AI

Figure 4.1 Detail of Programming Line.

See the information below for the whole parameter list and possible options of configuration.

4.1. Group 1 – G1: Options Menu

Parameter / Default Value	Name / Description	Range	Function	Set on RUN												
1 LOCK PARAMTRS=0	G1.1 / Parameter lock	0 – 2	<p>It allows user to lock SD700 parameters totally or partially. To lock you have to introduce a password in G1.2.</p> <table border="1"> <thead> <tr> <th>OPT</th> <th>DESCRIPTION</th> <th>FUNCTION</th> </tr> </thead> <tbody> <tr> <td>0</td> <td>NO</td> <td>Parameter lock is not active.</td> </tr> <tr> <td>1</td> <td>PARTIAL LOCK</td> <td>All of parameters are locked except for G1.1, G1.2, G3.3 and G6.2 (PID reference).</td> </tr> <tr> <td>2</td> <td>TOTAL LOCK</td> <td>Only G1.1 and G1.2 can be modified.</td> </tr> </tbody> </table>	OPT	DESCRIPTION	FUNCTION	0	NO	Parameter lock is not active.	1	PARTIAL LOCK	All of parameters are locked except for G1.1, G1.2, G3.3 and G6.2 (PID reference).	2	TOTAL LOCK	Only G1.1 and G1.2 can be modified.	YES
OPT	DESCRIPTION	FUNCTION														
0	NO	Parameter lock is not active.														
1	PARTIAL LOCK	All of parameters are locked except for G1.1, G1.2, G3.3 and G6.2 (PID reference).														
2	TOTAL LOCK	Only G1.1 and G1.2 can be modified.														
2 PASSWORD=OFF	G1.2 / Access password	OFF, 0000 – 9999	<p>It allows user to introduce a password to lock parameters and avoid unauthorized changes in the programming.</p> <p>If in G1.1 'Parameter lock', option '1 or 2' has been chosen, then this parameter appears automatically.</p> <p>Unlock: In G1.1 = 1 or 2 set to '0 → NO'. 2 PASSWORD_?OFF will be displayed.</p>	YES												
3 PSW ERR=XXXX	G1.2b / Unlock password recovery	0000 – 9999	<p>To recover the password the following formula can be used:</p> <p>Unlock password = (XXXX/2)-3.</p>	YES												
4 LANGUA=ESPAÑOL	G1.4 / Language selection	ENGLISH ESPAÑOL DEUTSCH PORTUGE	It allows selection of the user language.	NO												

Parameter / Default Value	Name / Description	Range	Function	Set on RUN																					
5 INITIALISE=0	G1.5 / Parameter initialize	0 – 5	<p>It allows selection of the parameters that we desire to initialize back to the factory default value.</p> <table border="1"> <thead> <tr> <th>OPT.</th> <th>DESCRIPTION</th> <th>FUNCTION</th> </tr> </thead> <tbody> <tr> <td>0</td> <td>NO INIT</td> <td>None of parameters is initialized.</td> </tr> <tr> <td>1</td> <td>USR PRMTR</td> <td>User parameters are only initialized.</td> </tr> <tr> <td>2</td> <td>MTR PRMTR</td> <td>Motor data are only initialized.</td> </tr> <tr> <td>3</td> <td>ALL PRMTR</td> <td>All parameters of the drive are initialized.</td> </tr> <tr> <td>4</td> <td>INIT_SOFT</td> <td>Newly added parameter values are initialized.</td> </tr> <tr> <td>5</td> <td>INIT_PARTIAL</td> <td>All parameters of the drive are initialized except communication parameters.</td> </tr> </tbody> </table>	OPT.	DESCRIPTION	FUNCTION	0	NO INIT	None of parameters is initialized.	1	USR PRMTR	User parameters are only initialized.	2	MTR PRMTR	Motor data are only initialized.	3	ALL PRMTR	All parameters of the drive are initialized.	4	INIT_SOFT	Newly added parameter values are initialized.	5	INIT_PARTIAL	All parameters of the drive are initialized except communication parameters.	NO
OPT.	DESCRIPTION	FUNCTION																							
0	NO INIT	None of parameters is initialized.																							
1	USR PRMTR	User parameters are only initialized.																							
2	MTR PRMTR	Motor data are only initialized.																							
3	ALL PRMTR	All parameters of the drive are initialized.																							
4	INIT_SOFT	Newly added parameter values are initialized.																							
5	INIT_PARTIAL	All parameters of the drive are initialized except communication parameters.																							
6 SHORTmenu=NO	G1.6 / To hide some configuration menus	NO YES	If it is active, then configuration menus will not be accessible. Only visible G1 OPTIONS MENU, G10 LIMITS, and Display groups.	NO																					
7 PROG= STANDARD	G1.7 / Program activation	STANDARD PUMP MACRO for VYSTA programs	<p>It allows selection additional functionalities. If PUMP is selected, then extended functionality for pumping control G25 will appear as available. The group G25 will be hidden if the pump program is not active. Furthermore, there are not available any configuration options related to pump control included in other parameters.</p> <p>Once selected the pump program, a character will appear in the upper line of the display, beside the drive status, indicating constantly that the pump program is active. The letter "b" in Spanish and the letter "p" for English / German.</p> <p>The most of parameters relative to the pump control are located in Group 25, excepting those setting relatives to inputs and outputs that can be found in groups G4 and G7.</p> <p>Additionally there are some visualization screens included in visualization groups SV.5 and SV.8.</p> <p>For additional information, see the 'Pump Application Manual' for the SD700.</p>	NO																					
SV 1.8 Visual																									
The programming line becomes a visualization line.																									
11 FAN CTRL=RUN	G1.11 / Drive fan control mode	RUN TEMP FIX	<p>It allows selecting the operation mode for drive fans.</p> <table border="1"> <thead> <tr> <th>OPTION</th> <th>FUNCTION</th> </tr> </thead> <tbody> <tr> <td>RUN</td> <td>The fans of the drive are connected with the start command and they are disconnected after 3 minutes once the drive is stopped.</td> </tr> <tr> <td>TEMP</td> <td>The fans are connected at 51°C and they are disconnected when temperature is below 47°C.</td> </tr> <tr> <td>FIX</td> <td>Starts the fans when the drive is not in external supply mode.</td> </tr> </tbody> </table>	OPTION	FUNCTION	RUN	The fans of the drive are connected with the start command and they are disconnected after 3 minutes once the drive is stopped.	TEMP	The fans are connected at 51°C and they are disconnected when temperature is below 47°C.	FIX	Starts the fans when the drive is not in external supply mode.	YES													
OPTION	FUNCTION																								
RUN	The fans of the drive are connected with the start command and they are disconnected after 3 minutes once the drive is stopped.																								
TEMP	The fans are connected at 51°C and they are disconnected when temperature is below 47°C.																								
FIX	Starts the fans when the drive is not in external supply mode.																								
12 RECT.BRIDGE=0	G1.12 / Amount of pulses of rectifier bridge	0 to 3	<p>It allows setting the amount of pulses of the rectifier bridge at the drive input.</p> <table border="1"> <thead> <tr> <th>OPT.</th> <th>DESCRIPTION</th> </tr> </thead> <tbody> <tr> <td>0</td> <td>6 PULSES</td> </tr> <tr> <td>1</td> <td>12 PULSES</td> </tr> <tr> <td>2</td> <td>18 PULSES</td> </tr> <tr> <td>3</td> <td>24 PULSES</td> </tr> </tbody> </table>	OPT.	DESCRIPTION	0	6 PULSES	1	12 PULSES	2	18 PULSES	3	24 PULSES	NO											
OPT.	DESCRIPTION																								
0	6 PULSES																								
1	12 PULSES																								
2	18 PULSES																								
3	24 PULSES																								
14 SER GRP PWD = OFF	Group reserved for the technical service and qualified personnel of Power Electronics																								

4.1.1. Subgroup 1.10 – S1.10: Eloader (EEPROM Charger)

Parameter / Default Value	Name / Description	Range	Function	Set on RUN
UPLOAD=N	G1.10.1 / Saves the parameters of the drive to the display.	N Y	When adjusting this value to Yes, the copy of parameters to the display starts, saving the configuration of the drive. A screen will appear showing the uploading progress: UPLOADING...100% When this process is over, the progress screen will automatically return to the main screen, set by default to No. Note: In order to carry out the parameter load correctly, the user should firstly configure the digital inputs concerning 'STOP' functions before any other function.	YES
DOWNLOAD=N	G1.10.2 / Saves the parameters of the display to the drive.	N Y	When adjusting this value to Yes, the copy of parameters stored in the display to the drive will start modifying and programming the parameters of this new drive. A screen will appear showing the downloading progress: DOWNLOADING ...100% When this process is over, the progress screen will automatically change to the main screen, set by default to No. Note: When using the Pump Applications. Before downloading parameters from the display, the parameter [G1.7] must be set as 'PUMP'.	NO

4.2. Group 2 – G2: Motor Nameplate Data

Parameter / Default Value	Name / Description	Range	Function	Set on RUN
1 MTR CUR=(*) MOTOR CURRENT	G2.1 / Motor rated current	1 – 9999A	It allows setting of the motor rated current according to its nameplate.	NO
2 MTR VOLT=400V MOTOR VOLTAGE	G2.2 / Motor rated voltage	220 – 999V	It allows setting of the motor rated voltage according to its nameplate.	NO
3 MTR PWR=(*) MOTOR POWER	G2.3 / Motor rated power	0 – 6500Kw	It allows setting of the motor rated power according to its nameplate.	NO
4 MTR RPM=1485 MOTOR SPEED(rpm)	G2.4 / Motor rpm	0 – 24000rpm	It allows setting of the motor rated speed according to its nameplate.	NO
5 MTR PFA=0.85 MTR POWER FACTOR	G2.5 / Cosine Phi	0 to 0.99	It allows setting of motor cosine Phi according its nameplate.	NO
6 MTR FRQ=50Hz MOTOR FREQUENCY	G2.6 / Motor rated frequency	0 – 100Hz	It allows setting of the motor rated frequency according to its nameplate.	NO
7 MTR COOLN=63% MOTOR COOLING	G2.7 / Motor cooling at zero speed	OFF, 5% – 100%	It provides adjustment of sensitive of the motor thermal model based on actual motor cooling. The following settings can be taken as reference: Submersible pumps and non-deflagrating motor → 5% Self-cool motor → 63% Forced-cool motor → 100% Note: If the drive is working at low speeds for a long time and several trips caused by motor thermal model are produced even though the motor was not hot then this value can be increased slightly to avoid further tripping. Note: If it is set to 'OFF', thermal model will be deactivated. Note: This protection estimates the temperature in the motor. To guarantee the motor protection, it is recommended to use the motor sensor (PTC).	NO

* This value depends on the drive rated current.

Note: If all of these values are not entered correctly, the SD700 will not operate correctly. When the motor nameplate offers multiple configuration possibilities, as in case of the start-delta motor connection, ensure the correct data is entered for the appropriate configuration.

4.3. Group 3 – G3: References

Parameter / Default Value	Name / Description	Range	Function	Set on RUN																				
1 REF1 SPD=LOCAL	G3.1 / Reference source 1 of speed	NONE AI1 AI2 AI1+AI2 FIB_1 LOCAL MREF PMOT PID COMMS FIB_2	<p>It allows selecting the source 1 or 2 for the speed reference.</p> <table border="1"> <thead> <tr> <th>OPTION</th> <th>FUNCTION</th> </tr> </thead> <tbody> <tr> <td>NONE</td> <td>Reference source 1 has not been selected.</td> </tr> <tr> <td>AI1</td> <td>Reference will be introduced through the Analogue Input 1.</td> </tr> <tr> <td>AI2</td> <td>Reference will be introduced through the Analogue Input 2.</td> </tr> <tr> <td>AI1+AI2</td> <td>Reference will be the sum of the signals introduced through the Analogue Inputs 1 and 2.</td> </tr> <tr> <td>LOCAL</td> <td>Reference will be given by keypad and will be set in 'G3.3'Local Speed Reference'.</td> </tr> <tr> <td>MREF</td> <td>Multi-Reference. Different references activated by the digital inputs. It will be necessary to configure the digital inputs. See 'S4.1 → Digital Inputs'.</td> </tr> <tr> <td>PMOT</td> <td>Motorized potentiometer with or without reference memory.</td> </tr> <tr> <td>PID</td> <td>It will take as reference the value set in the parameters of the PID function.</td> </tr> <tr> <td>COMMS</td> <td>The reference will be introduced through the communications.</td> </tr> </tbody> </table>	OPTION	FUNCTION	NONE	Reference source 1 has not been selected.	AI1	Reference will be introduced through the Analogue Input 1.	AI2	Reference will be introduced through the Analogue Input 2.	AI1+AI2	Reference will be the sum of the signals introduced through the Analogue Inputs 1 and 2.	LOCAL	Reference will be given by keypad and will be set in 'G3.3'Local Speed Reference'.	MREF	Multi-Reference. Different references activated by the digital inputs. It will be necessary to configure the digital inputs. See 'S4.1 → Digital Inputs'.	PMOT	Motorized potentiometer with or without reference memory.	PID	It will take as reference the value set in the parameters of the PID function.	COMMS	The reference will be introduced through the communications.	YES
	OPTION			FUNCTION																				
NONE	Reference source 1 has not been selected.																							
AI1	Reference will be introduced through the Analogue Input 1.																							
AI2	Reference will be introduced through the Analogue Input 2.																							
AI1+AI2	Reference will be the sum of the signals introduced through the Analogue Inputs 1 and 2.																							
LOCAL	Reference will be given by keypad and will be set in 'G3.3'Local Speed Reference'.																							
MREF	Multi-Reference. Different references activated by the digital inputs. It will be necessary to configure the digital inputs. See 'S4.1 → Digital Inputs'.																							
PMOT	Motorized potentiometer with or without reference memory.																							
PID	It will take as reference the value set in the parameters of the PID function.																							
COMMS	The reference will be introduced through the communications.																							
2 REF2 SPD=LOCAL	G3.2 / Reference source 2 of speed	<p>If the parameter G20.0.1 is set as OFC, the following options are shown too.</p> <table border="1"> <thead> <tr> <th>OPTION</th> <th>FUNCTION</th> </tr> </thead> <tbody> <tr> <td>FIB_1</td> <td>The drive speed reference will be the same as the master current speed reference.</td> </tr> <tr> <td>FIB_2</td> <td>The drive speed reference will be the master motor current speed (%)</td> </tr> </tbody> </table>	OPTION	FUNCTION	FIB_1	The drive speed reference will be the same as the master current speed reference.	FIB_2	The drive speed reference will be the master motor current speed (%)	YES															
OPTION	FUNCTION																							
FIB_1	The drive speed reference will be the same as the master current speed reference.																							
FIB_2	The drive speed reference will be the master motor current speed (%)																							
3 LOCAL SP=+100% LOCAL SPEED	G3.3 / Local Speed Reference	-250 to +250%	Allows the user to set the motor speed value if the reference source for speed has been set to 'LOCAL'.	YES																				
4 REF1 TQ = LOCAL	G3.4 / Torque Source reference 1	NONE AI1 AI2 AI1+AI2 FIB_1 LOCAL MREF PID COMMS FIB_2	<p>Allows to select supply 1 or supply 2 of the torque reference.</p> <table border="1"> <thead> <tr> <th>OPTION</th> <th>FUNCTION</th> </tr> </thead> <tbody> <tr> <td>NONE</td> <td>The supply reference 1 has not been selected.</td> </tr> <tr> <td>AI1</td> <td>The reference will be introduced through the analogue input 1.</td> </tr> <tr> <td>AI2</td> <td>The reference will be introduced through the analogue input 2.</td> </tr> <tr> <td>AI1+AI2</td> <td>The reference will be the addition of the signals introduced through the Analogue Inputs 1 and 2.</td> </tr> <tr> <td>LOCAL</td> <td>The reference will be introduced through keyboard and will be adjusted in G3.3 "Local Speed Reference".</td> </tr> <tr> <td>MREF</td> <td>Multi-reference. Different activated references by digital inputs. Digital inputs have to be configured. See S4.1 → Digital Inputs.</td> </tr> <tr> <td>PID</td> <td>Will assume as reference the value adjusted in the parameters of the PID.</td> </tr> <tr> <td>COMMS</td> <td>The reference will be introduced through the communications.</td> </tr> </tbody> </table>	OPTION	FUNCTION	NONE	The supply reference 1 has not been selected.	AI1	The reference will be introduced through the analogue input 1.	AI2	The reference will be introduced through the analogue input 2.	AI1+AI2	The reference will be the addition of the signals introduced through the Analogue Inputs 1 and 2.	LOCAL	The reference will be introduced through keyboard and will be adjusted in G3.3 "Local Speed Reference".	MREF	Multi-reference. Different activated references by digital inputs. Digital inputs have to be configured. See S4.1 → Digital Inputs.	PID	Will assume as reference the value adjusted in the parameters of the PID.	COMMS	The reference will be introduced through the communications.	YES		
	OPTION			FUNCTION																				
NONE	The supply reference 1 has not been selected.																							
AI1	The reference will be introduced through the analogue input 1.																							
AI2	The reference will be introduced through the analogue input 2.																							
AI1+AI2	The reference will be the addition of the signals introduced through the Analogue Inputs 1 and 2.																							
LOCAL	The reference will be introduced through keyboard and will be adjusted in G3.3 "Local Speed Reference".																							
MREF	Multi-reference. Different activated references by digital inputs. Digital inputs have to be configured. See S4.1 → Digital Inputs.																							
PID	Will assume as reference the value adjusted in the parameters of the PID.																							
COMMS	The reference will be introduced through the communications.																							
5 REF2 TQ = NONE	G3.5 / Torque supply reference 2	<p>If the parameter G20.0.1 is set as OFC, the following options are shown too.</p> <table border="1"> <thead> <tr> <th>OPTION</th> <th>FUNCTION</th> </tr> </thead> <tbody> <tr> <td>FIB_1</td> <td>The drive torque reference will be the same as the master current torque reference</td> </tr> <tr> <td>FIB_2</td> <td>The drive torque reference will be the master motor current torque (%)</td> </tr> </tbody> </table>	OPTION	FUNCTION	FIB_1	The drive torque reference will be the same as the master current torque reference	FIB_2	The drive torque reference will be the master motor current torque (%)																
OPTION	FUNCTION																							
FIB_1	The drive torque reference will be the same as the master current torque reference																							
FIB_2	The drive torque reference will be the master motor current torque (%)																							
6 LOCAL T= +100%	G3.6/ Local Torque reference	-250 to +250%	Allows the user to set the torque value of the motor if the torque reference source has been adjusted to "LOCAL".	YES																				

4.4. Group 4 – G4: Inputs

4.4.1. Subgroup 4.1 – S4.1: Digital Inputs

Parameter / Default Value	Name / Description	Range	Function	Set on RUN																								
1 CNTR0L MODE1=1	G4.1.1 / Main Control Mode	0 – 4	<p>It allows user to set the control mode for the drive commands (Start/Stop, Reset, ...).</p> <table border="1"> <thead> <tr> <th>OPT</th> <th>DESCRIPTION</th> <th>FUNCTION</th> </tr> </thead> <tbody> <tr> <td>0</td> <td>NONE</td> <td>Control mode 1 is not operative.</td> </tr> <tr> <td>1</td> <td>LOCAL</td> <td>Drive control is done by keypad.</td> </tr> <tr> <td>2</td> <td>REMOTE</td> <td>Drive controlled through control terminals.</td> </tr> <tr> <td>3</td> <td>COMMS</td> <td>Drive controlled through communication bus.</td> </tr> <tr> <td>4</td> <td>FIBER</td> <td>Drive controlled through optical fiber</td> </tr> </tbody> </table> <p>If the parameter G20.0.1 is set as OFC, the following options are shown too</p> <table border="1"> <thead> <tr> <th>OPT</th> <th>DESCRIPTION</th> <th>FUNCTION</th> </tr> </thead> <tbody> <tr> <td>4</td> <td>FIBER</td> <td>Drive controlled through optical fiber</td> </tr> </tbody> </table>	OPT	DESCRIPTION	FUNCTION	0	NONE	Control mode 1 is not operative.	1	LOCAL	Drive control is done by keypad.	2	REMOTE	Drive controlled through control terminals.	3	COMMS	Drive controlled through communication bus.	4	FIBER	Drive controlled through optical fiber	OPT	DESCRIPTION	FUNCTION	4	FIBER	Drive controlled through optical fiber	NO
OPT	DESCRIPTION	FUNCTION																										
0	NONE	Control mode 1 is not operative.																										
1	LOCAL	Drive control is done by keypad.																										
2	REMOTE	Drive controlled through control terminals.																										
3	COMMS	Drive controlled through communication bus.																										
4	FIBER	Drive controlled through optical fiber																										
OPT	DESCRIPTION	FUNCTION																										
4	FIBER	Drive controlled through optical fiber																										
2 CNTR0L MODE2=2	G4.1.2 / Alternative Control Mode	0 – 4	<p>It allows user to set the secondary control mode for the drive commands (Start/Stop, Reset, ...).</p> <table border="1"> <thead> <tr> <th>OPT</th> <th>DESCRIPTION</th> <th>FUNCTION</th> </tr> </thead> <tbody> <tr> <td>0</td> <td>NONE</td> <td>Control mode 2 is not operative.</td> </tr> <tr> <td>1</td> <td>LOCAL</td> <td>Drive control is done by keypad.</td> </tr> <tr> <td>2</td> <td>REMOTE</td> <td>Drive controlled through control terminals.</td> </tr> <tr> <td>3</td> <td>SERIAL COMMS</td> <td>Drive controlled through communication bus.</td> </tr> <tr> <td>4</td> <td>FIBER</td> <td>Drive controlled through optical fiber</td> </tr> </tbody> </table> <p>If the parameter G20.0.1 is set as OFC, the following options are shown too</p> <table border="1"> <thead> <tr> <th>OPT</th> <th>DESCRIPTION</th> <th>FUNCTION</th> </tr> </thead> <tbody> <tr> <td>4</td> <td>FIBER</td> <td>Drive controlled through optical fiber</td> </tr> </tbody> </table> <p>Note: Control mode 2 will be activated through digital inputs exclusively. To use this set one of the digital inputs to '17 → CONTROL 2'. When this input is activated, auxiliary control mode will be activated.</p>	OPT	DESCRIPTION	FUNCTION	0	NONE	Control mode 2 is not operative.	1	LOCAL	Drive control is done by keypad.	2	REMOTE	Drive controlled through control terminals.	3	SERIAL COMMS	Drive controlled through communication bus.	4	FIBER	Drive controlled through optical fiber	OPT	DESCRIPTION	FUNCTION	4	FIBER	Drive controlled through optical fiber	NO
OPT	DESCRIPTION	FUNCTION																										
0	NONE	Control mode 2 is not operative.																										
1	LOCAL	Drive control is done by keypad.																										
2	REMOTE	Drive controlled through control terminals.																										
3	SERIAL COMMS	Drive controlled through communication bus.																										
4	FIBER	Drive controlled through optical fiber																										
OPT	DESCRIPTION	FUNCTION																										
4	FIBER	Drive controlled through optical fiber																										
3 RESEt MODE=Y	G4.1.3 / Reset from keypad	N Y	<p>It allows user to reset faults from the keypad unit (LOCAL).</p> <table border="1"> <thead> <tr> <th>OPTION</th> <th>FUNCTION</th> </tr> </thead> <tbody> <tr> <td>N=NO</td> <td>It is not possible to reset from the keypad unit.</td> </tr> <tr> <td>Y=YES</td> <td>The drive can be reset via the reset button on the keypad unit.</td> </tr> </tbody> </table>	OPTION	FUNCTION	N=NO	It is not possible to reset from the keypad unit.	Y=YES	The drive can be reset via the reset button on the keypad unit.	YES																		
OPTION	FUNCTION																											
N=NO	It is not possible to reset from the keypad unit.																											
Y=YES	The drive can be reset via the reset button on the keypad unit.																											

Parameter / Default Value	Name / Description	Range	Function	Set on RUN																																																														
4 DIGIT I MODE=1	G4.1.4 / Selection of Digital Inputs configuration	0 – 5	<p>It allows user to configure the digital inputs for different functions. All the options described below will program to all the digital inputs simultaneously, except for option '1 → All Programmable', which allows to configure their in a separate way.</p> <table border="1"> <thead> <tr> <th>OPT</th> <th>DESCRIPTION</th> <th>FUNCTION</th> </tr> </thead> <tbody> <tr> <td>0</td> <td>3 WIRES</td> <td>'Start/Stop and Reset' by terminals. DI1 = 01 → Start (NO) DI2 = 04 → Stop 1-Reset (NC) DI3 = 03 → Stop 2-Reset (NC) DI4 = 15 → Reference 2 (NO) DI5 = 10 → Speed Inversion (NO) DI6 = 17 → Control 2 (NO)</td> </tr> <tr> <td>1</td> <td>ALL PROGRAMMABLE</td> <td>Inputs configuration individually by user. See G4.1.5 to G4.1.10.</td> </tr> <tr> <td>2</td> <td>MREF 2 WIRES</td> <td>Digital inputs 5 and 6 are programmed as multiple references (of speed or PID references) for up to 4 preset speeds. The remaining inputs are user programmable. <table border="1"> <thead> <tr> <th>PARAM</th> <th>DI5</th> <th>DI6</th> </tr> </thead> <tbody> <tr> <td>G14.4</td> <td>0</td> <td>0</td> </tr> <tr> <td>G14.5</td> <td>0</td> <td>X</td> </tr> <tr> <td>G14.6</td> <td>X</td> <td>0</td> </tr> <tr> <td>G14.7</td> <td>X</td> <td>X</td> </tr> </tbody> </table> <p>Note: It is necessary to set G3.1 REF1 SPD=MREF or G3.2 REF2 SPD=MREF.</p> </td> </tr> <tr> <td>3</td> <td>MREF 3 WIRES</td> <td>Digital inputs 4, 5 and 6 are programmed as multiple references (of speed or PID references) for up to 7 preset speeds. The remaining inputs are user programmable. <table border="1"> <thead> <tr> <th>PARAM</th> <th>DI4</th> <th>DI5</th> <th>DI6</th> </tr> </thead> <tbody> <tr> <td>G14.1</td> <td>0</td> <td>0</td> <td>X</td> </tr> <tr> <td>G14.2</td> <td>0</td> <td>X</td> <td>0</td> </tr> <tr> <td>G14.3</td> <td>0</td> <td>X</td> <td>X</td> </tr> <tr> <td>G14.4</td> <td>X</td> <td>0</td> <td>0</td> </tr> <tr> <td>G14.5</td> <td>X</td> <td>0</td> <td>X</td> </tr> <tr> <td>G14.6</td> <td>X</td> <td>X</td> <td>0</td> </tr> <tr> <td>G14.7</td> <td>X</td> <td>X</td> <td>X</td> </tr> </tbody> </table> <p>Note: It is necessary to set G3.1 REF1 SPD=MREF or G3.2 REF2 SPD=MREF.</p> </td> </tr> </tbody> </table>	OPT	DESCRIPTION	FUNCTION	0	3 WIRES	'Start/Stop and Reset' by terminals. DI1 = 01 → Start (NO) DI2 = 04 → Stop 1-Reset (NC) DI3 = 03 → Stop 2-Reset (NC) DI4 = 15 → Reference 2 (NO) DI5 = 10 → Speed Inversion (NO) DI6 = 17 → Control 2 (NO)	1	ALL PROGRAMMABLE	Inputs configuration individually by user. See G4.1.5 to G4.1.10.	2	MREF 2 WIRES	Digital inputs 5 and 6 are programmed as multiple references (of speed or PID references) for up to 4 preset speeds. The remaining inputs are user programmable. <table border="1"> <thead> <tr> <th>PARAM</th> <th>DI5</th> <th>DI6</th> </tr> </thead> <tbody> <tr> <td>G14.4</td> <td>0</td> <td>0</td> </tr> <tr> <td>G14.5</td> <td>0</td> <td>X</td> </tr> <tr> <td>G14.6</td> <td>X</td> <td>0</td> </tr> <tr> <td>G14.7</td> <td>X</td> <td>X</td> </tr> </tbody> </table> <p>Note: It is necessary to set G3.1 REF1 SPD=MREF or G3.2 REF2 SPD=MREF.</p>	PARAM	DI5	DI6	G14.4	0	0	G14.5	0	X	G14.6	X	0	G14.7	X	X	3	MREF 3 WIRES	Digital inputs 4, 5 and 6 are programmed as multiple references (of speed or PID references) for up to 7 preset speeds. The remaining inputs are user programmable. <table border="1"> <thead> <tr> <th>PARAM</th> <th>DI4</th> <th>DI5</th> <th>DI6</th> </tr> </thead> <tbody> <tr> <td>G14.1</td> <td>0</td> <td>0</td> <td>X</td> </tr> <tr> <td>G14.2</td> <td>0</td> <td>X</td> <td>0</td> </tr> <tr> <td>G14.3</td> <td>0</td> <td>X</td> <td>X</td> </tr> <tr> <td>G14.4</td> <td>X</td> <td>0</td> <td>0</td> </tr> <tr> <td>G14.5</td> <td>X</td> <td>0</td> <td>X</td> </tr> <tr> <td>G14.6</td> <td>X</td> <td>X</td> <td>0</td> </tr> <tr> <td>G14.7</td> <td>X</td> <td>X</td> <td>X</td> </tr> </tbody> </table> <p>Note: It is necessary to set G3.1 REF1 SPD=MREF or G3.2 REF2 SPD=MREF.</p>	PARAM	DI4	DI5	DI6	G14.1	0	0	X	G14.2	0	X	0	G14.3	0	X	X	G14.4	X	0	0	G14.5	X	0	X	G14.6	X	X	0	G14.7	X	X	X	NO
			OPT	DESCRIPTION	FUNCTION																																																													
			0	3 WIRES	'Start/Stop and Reset' by terminals. DI1 = 01 → Start (NO) DI2 = 04 → Stop 1-Reset (NC) DI3 = 03 → Stop 2-Reset (NC) DI4 = 15 → Reference 2 (NO) DI5 = 10 → Speed Inversion (NO) DI6 = 17 → Control 2 (NO)																																																													
			1	ALL PROGRAMMABLE	Inputs configuration individually by user. See G4.1.5 to G4.1.10.																																																													
2	MREF 2 WIRES	Digital inputs 5 and 6 are programmed as multiple references (of speed or PID references) for up to 4 preset speeds. The remaining inputs are user programmable. <table border="1"> <thead> <tr> <th>PARAM</th> <th>DI5</th> <th>DI6</th> </tr> </thead> <tbody> <tr> <td>G14.4</td> <td>0</td> <td>0</td> </tr> <tr> <td>G14.5</td> <td>0</td> <td>X</td> </tr> <tr> <td>G14.6</td> <td>X</td> <td>0</td> </tr> <tr> <td>G14.7</td> <td>X</td> <td>X</td> </tr> </tbody> </table> <p>Note: It is necessary to set G3.1 REF1 SPD=MREF or G3.2 REF2 SPD=MREF.</p>	PARAM	DI5	DI6	G14.4	0	0	G14.5	0	X	G14.6	X	0	G14.7	X	X																																																	
PARAM	DI5	DI6																																																																
G14.4	0	0																																																																
G14.5	0	X																																																																
G14.6	X	0																																																																
G14.7	X	X																																																																
3	MREF 3 WIRES	Digital inputs 4, 5 and 6 are programmed as multiple references (of speed or PID references) for up to 7 preset speeds. The remaining inputs are user programmable. <table border="1"> <thead> <tr> <th>PARAM</th> <th>DI4</th> <th>DI5</th> <th>DI6</th> </tr> </thead> <tbody> <tr> <td>G14.1</td> <td>0</td> <td>0</td> <td>X</td> </tr> <tr> <td>G14.2</td> <td>0</td> <td>X</td> <td>0</td> </tr> <tr> <td>G14.3</td> <td>0</td> <td>X</td> <td>X</td> </tr> <tr> <td>G14.4</td> <td>X</td> <td>0</td> <td>0</td> </tr> <tr> <td>G14.5</td> <td>X</td> <td>0</td> <td>X</td> </tr> <tr> <td>G14.6</td> <td>X</td> <td>X</td> <td>0</td> </tr> <tr> <td>G14.7</td> <td>X</td> <td>X</td> <td>X</td> </tr> </tbody> </table> <p>Note: It is necessary to set G3.1 REF1 SPD=MREF or G3.2 REF2 SPD=MREF.</p>	PARAM	DI4	DI5	DI6	G14.1	0	0	X	G14.2	0	X	0	G14.3	0	X	X	G14.4	X	0	0	G14.5	X	0	X	G14.6	X	X	0	G14.7	X	X	X																																
PARAM	DI4	DI5	DI6																																																															
G14.1	0	0	X																																																															
G14.2	0	X	0																																																															
G14.3	0	X	X																																																															
G14.4	X	0	0																																																															
G14.5	X	0	X																																																															
G14.6	X	X	0																																																															
G14.7	X	X	X																																																															
Note: See following page.																																																																		

Parameter / Default Value	Name / Description	Range	Function	Set on RUN									
4 DIGIT I MODE=1	G4.1.4 / Selection of Digital Inputs configuration	0 – 5	<p>Note: Coming from the previous page.</p> <table border="1"> <thead> <tr> <th>OPT</th> <th>DESCRIPTION</th> <th>FUNCTION</th> </tr> </thead> <tbody> <tr> <td>4</td> <td>MOTORIZED POT</td> <td>It assigns the up and down reference function for two of the digital inputs. DI5 = Up (NO contact) DI6 = Down (NC contact) Reference limits will be the speed limits set in 'G10 LIMITS'. Programming a change ramp is possible at: G5.7 PMT ACL1=3%/s G5.8 PMT DCL1=3%/s G5.9 PMT ACL2=1%/s G5.10 PMT DCL2=1%/s G5.11 PMOT BRK=OFF Note: In this mode, the reference set by potentiometer will be memorized even if the motor is stopped and also in the case of a power loss.</td> </tr> <tr> <td>5</td> <td>ERASAB POT</td> <td>It operates in the same way as option 4, but when the motor is stopped or a power loss occurs, the reference will not be memorized. In this case the minimum reference value set in G10.1 or G10.3 will be the default speed. This will happen when the limit is above zero, if the limit is equal or below zero, the default speed will be zero.</td> </tr> </tbody> </table>	OPT	DESCRIPTION	FUNCTION	4	MOTORIZED POT	It assigns the up and down reference function for two of the digital inputs. DI5 = Up (NO contact) DI6 = Down (NC contact) Reference limits will be the speed limits set in 'G10 LIMITS'. Programming a change ramp is possible at: G5.7 PMT ACL1=3%/s G5.8 PMT DCL1=3%/s G5.9 PMT ACL2=1%/s G5.10 PMT DCL2=1%/s G5.11 PMOT BRK=OFF Note: In this mode, the reference set by potentiometer will be memorized even if the motor is stopped and also in the case of a power loss.	5	ERASAB POT	It operates in the same way as option 4, but when the motor is stopped or a power loss occurs, the reference will not be memorized. In this case the minimum reference value set in G10.1 or G10.3 will be the default speed. This will happen when the limit is above zero, if the limit is equal or below zero, the default speed will be zero.	NO
			OPT	DESCRIPTION	FUNCTION								
4	MOTORIZED POT	It assigns the up and down reference function for two of the digital inputs. DI5 = Up (NO contact) DI6 = Down (NC contact) Reference limits will be the speed limits set in 'G10 LIMITS'. Programming a change ramp is possible at: G5.7 PMT ACL1=3%/s G5.8 PMT DCL1=3%/s G5.9 PMT ACL2=1%/s G5.10 PMT DCL2=1%/s G5.11 PMOT BRK=OFF Note: In this mode, the reference set by potentiometer will be memorized even if the motor is stopped and also in the case of a power loss.											
5	ERASAB POT	It operates in the same way as option 4, but when the motor is stopped or a power loss occurs, the reference will not be memorized. In this case the minimum reference value set in G10.1 or G10.3 will be the default speed. This will happen when the limit is above zero, if the limit is equal or below zero, the default speed will be zero.											
<p> Caution: Digital input configuration changes their settings automatically. Make sure there is not a hazard due to accidental motor starting that can cause property damage or personal injury.</p>													

Pumps program activation, in G1.7 PROG = PUMP, requires the following considerations:

There are some configuration options available when the pump program is active, which can be set in the same way that the options available in the standard program.

Nevertheless, when the pump program is active, the drive will assume that only the configurable options from 50 to 75 (for G4.1.5 to G4.1.10) can be set, without taking into consideration the setting on parameter 'G4.1.4 DIGIT I MODE', which means a block setting.

All that means that the user will configure the pump program freely, according to his requirements, selecting the correct functionality and protections. For a correct programming of the digital inputs when the pump program is active, there is additional information in 'Pump Application Manual', where information about Pump Control (G25) is included.

Note: Selection of the pump program will set all the Digital Inputs to mode '00 – un used'. If re-programming is needed, it will be necessary to configure their functionality in a separate way again. So it guarantees a safety installation operation, avoiding that hardware external to the equipment can cause any kind of damage.

Note: The digital outputs will also be affected due to pump control activation.

To select one auxiliary pump it is necessary to act in the following way:

- Set any free digital input to options '52 FIX PUMP1 FLT', '53 FIX PUMP2 FLT', '54 FIX PUMP3 FLT', '55 FIX PUMP4 FLT' or '56 FIX PUMP5 FLT'
- To enable the control of the pump in the corresponding screen G25.9.1, G25.9.2, G25.9.3, G25.9.4 and G25.9.5 respectively.

To remove this pump configuration and release the relay for another use, the user should:

- Disable the control of the pump in the corresponding screen G25.9.1, G25.9.2, G25.9.3, G25.9.4 or G25.9.5 respectively.

Parameter / Default Value	Name / Description	Range	Function	Set on RUN		
5 DIGITL IN 1=06	G4.1.5 / Multi-function Digital Input 1 configuration	00 – 75	It allows user to configure the digital inputs for individual use.		NO	
			OPT	DESCRIPTION		FUNCTION
			00	NO USE		Input is disabled.
			01	START		'Start' command from a normally open push button (NO). First, it is necessary to configure another input as a 'Stop' command from a normally closed contact (NC).
			02	STOP1		'Stop' command from a normally closed push button. Stop mode is adjusted in G7.1 STOP 1. (NC)
6 DIGITL IN 2=00	G4.1.6 / Multi-function Digital Input 2 configuration	00 – 75	03	STOP2-RESET		'Stop' command from a normally closed pushbutton. Stop mode is adjusted in G7.2 STOP 2. Activation of the input in this mode also acts as a 'Reset' signal. (NC)
			04	STOP1-RESET		'Stop' command from a normally closed pushbutton. Stop mode is adjusted in G7.1 STOP 1. Activation of the input in this mode also acts as a 'Reset' signal. (NC)
			05	START/STOP		It allows start when closed, and stop when open (2 wires start / stop). (NO)
7 DIGITL IN 3=00	G4.1.7 / Multi-function Digital Input 3 configuration	00 – 75	06	START-RST/STOP		It allows start when closed and stop when open (2 wires start / stop). Activation of this input also acts a fault reset. (NO)
			07	RESET		'Reset' signal by push button. (NC). See Note .
			08	START + INCH1		'Start' command and inch speed 1 when closed. Inch speed is programmed in G15.1 INCH1. (NO)
			09	START + INCH2		'Start' command and inch speed 2 when closed. Inch speed is programmed in G15.2 INCH2. (NO)
			10	INV SPEED		It causes deceleration of the motor until motor is stopped, and inverts the rotation direction. (NO) ^[2]
8 DIGITL IN 4=00	G4.1.8 / Multi-function Digital Input 4 configuration	00 – 75	11	RESERVE		Reserved for future use.
			12	RESERVE		Reserved for future use.
			13	INV INCHS		It inverts the fixed speed reference set in G15.1, G15.2 or G15.3. (NO) ^[2]
			14	ACC/DEC 2		It active acceleration and deceleration ramps are enabled. Alternative acceleration and deceleration rates are programmed in G5.3 and G5.4. (NO)
			15	REFERENCE 2		It allows selection of the alternative speed reference as programmed in G3.2. (NO)
			16	RESERVE		Reserved for future use.
9 DIGITL IN 5=00	G4.1.9 / Multi-function Digital Input 5 configuration	00 – 75	17	CONTROL 2		It activates the alternative control mode as programmed in G4.1.2. (NO)
			18	START/STP – RST	Like the option 06, but 'Reset' signal will be activated after the drive is stopped. (NO)	
			19	STOP (2)	'Stop' command from a normally closed pushbutton. Stop mode is adjusted in G7.2 STOP 2. (NC)	
			20	SPEED LIMIT 2	It will change to the alternative speed limits as programmed in G10.3 and G10.4. (NO).	
			Note: See following page.			

Note: The user can choose this option independently of the selected program (STÁNDARD or PUMP) and the used control mode (LOCAL, REMOTE, SERIAL COMMS).

^[1] If two inputs set to options '08 → START + INCH1' and '09 → START + INCH2' are activated at the same time the combination of 'START + INCH3' programmed in G15.3 INCH3 is enabled.

^[2] Rotation inversion in 'G10.11 INVERSION ?=Y' must be enabled.

Parameter / Default Value	Name / Description	Range	Function	Set on RUN		
10 DIGITL IN6=17	G4.1.10 / Multi-function Digital Input 6 configuration	00 – 75	Note: Coming from the previous page.		NO	
			OPT	DESCRIPTION		FUNCTION
			21	DC BRAKE		It activates or deactivates dynamic brake unit. (NO)
			22	START MODE 2		To select the alternative starting mode (Ramp / Spin) (NO)
			23	CURRENT LIM2		To select the alternative current limit. (NO)
			24	EXTERN EMERGE		To generate the fault 'F56 EMERGEN.STOP'. (NC). See Note .
			25	FREMAQ FLT		It is an emergency stop which indicates fault in the freemaq filter (NC). Drive will trip by fault 78 TMP FREEMAQ.
			26	SPEED/TORQUE (*)		Switches between speed mode (NO) and torque mode (NC)
			27	STRT/STOP + INV		Start/Stop + rotation reversal. Start the equipment with this digital input means starting in the opposite direction of the reference speed sign.
			28	Dig Output FB		(NC) drive works normally, but, in OPEN state, when the [G8.1.35] expires, drive will trip by fault 55. See parameter G8.1.34..
40	U.STOP	It stops the drive regardless of control mode & program selection configured (NO).				
Parameters 70 and 75 available with the pump software.						

(*)Available if G19.1.1 = VECT and G19.1.2 = PMC/AVC

Note: The user can choose this option independently of the selected program (STÁNDARD or PUMP) or the control mode used (LOCAL, REMOTE, and SERIAL COMMS).

4.4.2. Subgroup 4.2 – S4.2: Analogue Input 1

Parameter / Default Value	Name / Description	Range	Function	Set on RUN						
1 SENSOR 1 ?=N	G4.2.1 / To enable sensor of Analogue Input 1	N Y	It allows user to configure analogue input 1 for use with a sensor and activates the parameters which are necessary to set it up. See G4.2.2 up to G4.2.7. <table border="1"> <thead> <tr> <th>OPTION</th> <th>FUNCTION</th> </tr> </thead> <tbody> <tr> <td>N=NO</td> <td>The analogue input will remain scaled in default units (%).</td> </tr> <tr> <td>Y=YES</td> <td>The analogue input and any variables relating to the analogue input will be configured in the engineering units selected in G4.2.2.</td> </tr> </tbody> </table>	OPTION	FUNCTION	N=NO	The analogue input will remain scaled in default units (%).	Y=YES	The analogue input and any variables relating to the analogue input will be configured in the engineering units selected in G4.2.2.	YES
OPTION	FUNCTION									
N=NO	The analogue input will remain scaled in default units (%).									
Y=YES	The analogue input and any variables relating to the analogue input will be configured in the engineering units selected in G4.2.2.									
2 SENSOR 1=l/s ^[3]	G4.2.2 / Selection of sensor 1 units	% l/s m ³ /s l/m m ³ /m l/h m ³ /h m/s m/m m/h Bar kPa Psi m °C °F °K Hz rpm	It allows selection of different units of measurement for analogue input 1 according to the sensor that is used. If this parameter is modified, the minimum and maximum values of the sensor range must be adjusted to ensure correct configuration. Therefore, the following set values should be checked: 'G4.2.5 Smi1=+0.0l/s' → Minimum range of sensor. 'G4.2.7 Sma1=+10.0l/s' → Maximum range of sensor.	YES						

^[3] Available only when 'G4.2.1 SENSOR 1 = Y'.

Parameter / Default Value	Name / Description	Range	Function	Set on RUN						
3 AIN1 FORMAT=V	G4.2.3 / Analogue Input 1 format	V mA	It allows configuration of the analogue input 1 format for either a voltage or current signal. Set according to the sensor that will be used.	YES						
4 INmin1=+0V AIN1 LOW RANGE	G4.2.4 / Minimum range of Analogue Input 1	-10V to G4.2.6 +0mA to G4.2.6	It determines the minimum voltage or current value for analogue input 1. Set according to the characteristics of the sensor that will be connected.	YES						
5 Smi1=+0.0/s ^[3] SENS1 LOW RANGE	G4.2.5 / Minimum range of sensor 1	-3200 to G4.2.7 Engineering units	It sets the minimum units value of the sensor connected to analogue input 1. This value should also correspond to the minimum voltage or current level of the sensor set in 'G4.2.4 INmin1'. Note: This value should be checked if the units are changed in 'G4.2.2 SENSOR 1'. It will be set to operate in open loop and close loop.	YES						
6 INmax1=+10V AIN1 HIGH RANGE	G4.2.6 / Maximum range of Analogue Input 1	G4.2.4 to +10V G4.2.4 to +20mA	It determines the maximum voltage or current value for analogue input 1. Set according to the characteristics of the sensor that will be connected.	YES						
7 Sma1=+10.0/s ^[3] SENS1 HIGH RANGE	G4.2.7 / Maximum range of sensor 1	G4.2.5 to +3200 Engineering units	It sets the maximum units value of the sensor connected to analogue input 1. This value should also correspond to the maximum voltage or current level of the sensor set in 'G4.2.6 INmax1'. Note: This value should be checked if the units are changed in 'G4.2.2 SENSOR 1'. For this, it is necessary to set this value in open loop and close loop configurations.	YES						
8 SPD LO1=+0% SPD LO RNG AIN1	G4.2.8 / Speed for the minimum range of Analogue Input 1	-250% to G4.2.9	It allows scaling of the speed reference to correspond with the minimum range of the analogue input 1 as set in 'G4.2.4 INmin1'. The value is a percentage of the motor rated speed.	YES						
9 SPD HI1=+100% SPD HIG RNG AIN1	G4.2.9 / Speed for the maximum range Analogue Input 1	G4.2.8 to +250%	It allows scaling of the speed reference to correspond with the maximum range of the analogue input 1 as set in 'G4.2.6 INmax1'. The value is a percentage of the motor rated speed.	YES						
10 FB1 = + 0.0/s ^[3]	G4.2.10 / Minimum operating range of sensor	-3200 to G4.2.12 Engineering units	To set the minimum operating range, if the real operating range is different than the range of the sensor which will be used as sensor in open loop. It corresponds with the voltage or current level set in 'G4.2.4INmin1'. This parameter should be configured to operate with sensor in open loop.	YES						
11 FB1 – Sp = 0% ^[3]	G4.2.11 / Minimum speed range for sensor in open loop	-250% to +250%	It allows setting the minimum speed range corresponding to the minimum sensor range set in 'G4.2.10 FB1', when the sensor will be used in open loop. The value is a percentage of the motor rated speed.	YES						
12 FA1 = +10.0/s ^[3]	G4.2.12 / Maximum operating range of sensor	G4.2.10 to +3200 Engineering units	To set the maximum operating range, if the real operating range is different than the range of the sensor which will be used as sensor in open loop. It corresponds with the voltage or current level set in 'G4.2.6INmin1'. This parameter should be configured to operate with sensor in open loop.	YES						
13 FA1 – SP = 100% ^[3]	G4.2.13 / Maximum speed range for sensor in open loop	-250% to +250%	It allows setting the maximum speed range corresponding to the maximum sensor range set in 'G4.2.12 FA1', when the sensor will be used in open loop. The value is a percentage of the motor rated speed.	YES						
14 AIN1 LOSS=N	G4.2.14 / Protection for Analogue Input 1 loss	N Y	To set the drive stop mode when a loss of the analogue input 1 signal occurs. <table border="1" style="margin-left: auto; margin-right: auto;"> <thead> <tr> <th>OPTION</th> <th>FUNCTION</th> </tr> </thead> <tbody> <tr> <td>N=NO</td> <td>Function disabled.</td> </tr> <tr> <td>Y=YES</td> <td>When the analogue input level decreases down to zero value, sensor will be considered damaged and the drive will stop generating a fault 'F42 AIN1 LOSS'.</td> </tr> </tbody> </table>	OPTION	FUNCTION	N=NO	Function disabled.	Y=YES	When the analogue input level decreases down to zero value, sensor will be considered damaged and the drive will stop generating a fault 'F42 AIN1 LOSS'.	YES
OPTION	FUNCTION									
N=NO	Function disabled.									
Y=YES	When the analogue input level decreases down to zero value, sensor will be considered damaged and the drive will stop generating a fault 'F42 AIN1 LOSS'.									
15 1_Z BAND=OFF AIN1 ZERO BAND	G4.2.15 / Zero band filter for Analogue Input 1	OFF = 0.0, 0.1 to 2.0%	Filtering of analogue input 1 signal. Setting this value we can filter analogue input 1 to avoid possible electrical noise preventing the analogue reading a zero value.	YES						
16 FILTER1=OFF AIN1 STABIL FILT	G4.2.16 / Low Pass filter for Analogue Input 1	OFF = 0.0, 0.1 to 20.0%	It allows filtering the Analogue Input 1 signal. Setting the value of this time constant we can eliminate possible instabilities in the value of the same ones due to noise, wiring faults, etc. Note: When applying a Low Pass filter to any analogue signal, a delay time in the own signal is generated. This delay time is the value of the configured time constant approximately.	YES						

^[3] Available only when 'G4.2.1 SENSOR 1 = Y'.

4.4.3. Subgroup 4.3 – S4.3: Analogue Input 2

Parameter / Default Value	Name / Description	Range	Function	Set on RUN						
1 SENSOR 2 ?=N	G4.3.1 / Sensor of Analogue Input 2 enable	N Y	<p>It allows user to configure analogue input 2 for use with a sensor and activates the parameters which are necessary to set it up. See G4.3.2 up to G4.3.7.</p> <table border="1"> <thead> <tr> <th>OPTION</th> <th>FUNCTION</th> </tr> </thead> <tbody> <tr> <td>N=NO</td> <td>The analogue input will remain scaled in default units (%).</td> </tr> <tr> <td>Y=YES</td> <td>The analogue input and any variables relating to the analogue input will be configured in the engineering units selected in G4.3.2.</td> </tr> </tbody> </table>	OPTION	FUNCTION	N=NO	The analogue input will remain scaled in default units (%).	Y=YES	The analogue input and any variables relating to the analogue input will be configured in the engineering units selected in G4.3.2.	YES
OPTION	FUNCTION									
N=NO	The analogue input will remain scaled in default units (%).									
Y=YES	The analogue input and any variables relating to the analogue input will be configured in the engineering units selected in G4.3.2.									
2 SENSOR 2=Bar ^[4]	G4.3.2 / Selection of sensor 2 units	% l/s m ³ /s l/m m ³ /m l/h m ³ /h m/s m/m m/h Bar kPa Psi m °C °F °K Hz rpm	<p>It allows selection of different units of measurement for the analogue input 2 according to the sensor that is used.</p> <p>If this parameter is modified, the minimum and maximum values of the sensor range must be adjusted to ensure correct configuration. Therefore, the following set values should be checked: 'G4.3.5 S_{mi2}=+0.0Bar' → Minimum range of sensor. 'G4.3.7 S_{ma2}=+10.0Bar' → Maximum range of sensor.</p>	YES						
3 AIN2 FORMAT=mA	G4.3.3 / Analogue Input 2 format	V mA	It allows configuration of the analogue input 2 format for either a voltage or current signal. Set according to the sensor that will be used.	YES						
4 IN _{min2} =+4mA AIN2 LOW RANGE	G4.3.4 / Minimum range of Analogue Input 2	-10V to G4.3.6 +0mA to G4.3.6	It determines the minimum voltage or current value for analogue input 2. Set according to the characteristics of the sensor that will be connected.	YES						
5 S _{mi2} =+0.0Bar ^[4] SENS2 LOW RANGE	G4.3.5 / Minimum range of sensor 2	-3200 to G4.3.7 Engineering units	<p>It sets the minimum units value of the sensor connected to the analogue input 2. This value should also correspond to the minimum voltage or current level of the sensor set in 'G4.3.4 IN_{min2}'.</p> <p>Note: This value should be checked if the units are changed in 'G4.3.2 SENSOR 2'. It will be set to operate in open loop and close loop.</p>	YES						
6 IN _{max2} =+20mA AIN2 HIGH RANGE	G4.3.6 / Maximum range of Analogue Input 2	G4.3.4 to +10V G4.3.4 to +20mA	It determines the maximum voltage or current value for the analogue input 2. Set according to the characteristics of the sensor that will be connected.	YES						
7 S _{ma2} =+10.0Bar ^[4] SENS2 HIGH RANGE	G4.3.7 / Maximum range of sensor 2	G4.3.5 to +3200 Engineering units	<p>It sets the maximum units value of the sensor connected to the analogue input 2. This value should also correspond to the maximum voltage or current level of the sensor set in 'G4.3.6 IN_{max2}'.</p> <p>Note: This value should be checked if the units are changed in 'G4.3.2 SENSOR 2'. It is necessary to set this value in open loop and close loop configurations.</p>	YES						
8 SPD LO2=+0% SPD LO RNG AIN2	G4.3.8 / Speed for the minimum range of Analogue Input 2	-250% to G4.3.9	It allows scaling of the speed reference to correspond with the minimum range of the analogue input 2 as set in 'G4.3.4 IN _{min2} '. It is configured to set the speed reference via analogue input. Set the parameter 'G4.3.1 SENSOR 2 ?= N'. The value is a percentage of the motor rated speed.	YES						
9 SPD HI2=+100% SPD HIG RNG AIN2	G4.3.9 / Speed for the maximum range of Analogue Input 2	G4.3.8 to +250%	It allows scaling of the speed reference to correspond with the maximum range of the analogue input 2 as set in 'G4.3.6 IN _{max2} '. It is configured to set the speed reference via analogue input. Set the parameter 'G4.3.1 SENSOR 2 ?= N'. The value is a percentage of the motor rated speed.	YES						
10 FB2 = + 0.0Bar ^[4]	G4.3.10 / Minimum operating range of sensor	-3200 to G4.3.12 Engineering units	To set the minimum operating range, if the real operating range is different than the range of the sensor which will be used as sensor in open loop. It corresponds with the voltage or current level set in 'G4.3.4 IN _{min2} '. This parameter should be configured to operate with sensor in open loop.	YES						
11 FB2 – Sp = 0% ^[4]	G4.3.11 / Minimum speed range for sensor in open loop	-250% to +250%	It allows setting the minimum speed range corresponding to the minimum sensor range set in 'G4.3.10 FB2', when the sensor will be used in open loop. The value is a percentage of the motor rated speed.	YES						

^[4] It will be available in case of 'G4.3.1 SENSOR 2 = Y'.

Parameter / Default Value	Name / Description	Range	Function	Set on RUN						
12 FA2 = +10.0Bar [4]	G4.3.12 / Maximum operating range of sensor	G4.3.10 to +3200 Engineering units	To set the maximum operating range, if the real operating range is different than the range of the sensor which will be used as sensor in open loop. It corresponds with the voltage or current level set in 'G4.3.6INmin2'. This parameter should be configured to operate with sensor in open loop.	YES						
13 FA2 – SP = 100%[4]	G4.3.13 / Maximum speed range for sensor in open loop	-250% to +250%	It allows setting the maximum speed range corresponding to the maximum sensor range set in 'G4.3.12 FA2', when the sensor will be used in open loop. The value is a percentage of the motor rated speed.							
14 AIN2 LOSS=N	G4.3.14 / Protection for Analogue Input 2 loss	N Y	To set the drive stop mode when a loss of the analogue input 2 signal occurs. <table border="1"> <thead> <tr> <th>OPTION</th> <th>FUNCTION</th> </tr> </thead> <tbody> <tr> <td>N=NO</td> <td>Function disabled.</td> </tr> <tr> <td>Y=YES</td> <td>When the analogue input level decreases down to zero value, sensor will be considered damaged and the drive will stop generating a fault 'F43 AIN2 LOSS'.</td> </tr> </tbody> </table>	OPTION	FUNCTION	N=NO	Function disabled.	Y=YES	When the analogue input level decreases down to zero value, sensor will be considered damaged and the drive will stop generating a fault 'F43 AIN2 LOSS'.	YES
OPTION	FUNCTION									
N=NO	Function disabled.									
Y=YES	When the analogue input level decreases down to zero value, sensor will be considered damaged and the drive will stop generating a fault 'F43 AIN2 LOSS'.									
15 2_Z BAND=OFF AIN2 ZERO BAND	G4.3.15 / Zero band filter for Analogue Input 2	OFF=0.0, 0.1 to 2.0%	Filtering of analogue input 2 signal. Setting this value we can filter analogue input 2 to avoid possible electrical noise preventing the analogue reading a zero value.	YES						
16 FILTER2=OFF AIN2 STABIL FILT	G4.3.16 / Low Pass filter for Analogue Input 2	OFF = 0.0, 0.1 to 20.0%	It allows filtering the Analogue Input 2 signal. Setting the value of this time constant we can eliminate possible instabilities in the value of the same ones due to noise, wiring faults, etc. Note: When applying a Low Pass filter to any analogue signal, a delay time in the own signal is generated. This delay time is the value of the configured time constant approximately.	YES						

[4] It will be available in case of 'G4.3.1 SENSOR 2 = Y'.

4.4.4. Subgroup 4.4 – S4.4: Pulse Input

Parameter / Default Value	Name / Description	Range	Function	Set on RUN
1 Sensr U=l/s	G4.4.1 / Sensor units of Pulse Input	% l/s m³/s l/m m³/m l/h m³/h m/s m/m m/h	Allows selection of the units to measure the flow. Note: To use this input you should have a flowmeter with a digital pulse output of pulse width greater than 50ms. Used for flow limitation algorithm. See S25.10.	YES
2 Pls/s = 100l/s LIQU AMOUNT/PULS	G4.4.2 / Flowmeter configuration	0 to 32760 Flow units	It allows setting the amount of the fluid per pulse received. For example, if setting is '2Pls/s=100l/s', and the present flow is 500l/s, 5 pulses/sec will be received.	YES
3 M Rn=1000l/s FLOW MAX RANGE	G4.4.3 / Maximum range of flow meter	0 to 32760 Flow units	It allows user to set the maximum range of the flow meter. It is used to calculate the reset level of the flow control algorithm. Parameter G25.10.4 is linked with the value set in this parameter. Example: If you set a maximum range of 100 units 'G4.4.3=100', and the reset level of the flow algorithm is desired below 30 units, you have to set 'G25.10.4=30%'. For additional information, see the 'Pump Application Manual' for the SD700.	YES

4.4.5. Subgroup 4.6 – S4.6: Optic Fiber

4.4.5.1. Subgroup S4.6.1 – 1. MODO FIBRA

Parameter / Default Value	Name / Description	Range	Function	Set on RUN												
1 FIBER MODE = 0	G4.6.1 / Fiber Mode	0-2	This parameter is used to select the drive role in the optical fiber network. We can select three options: <table border="1"> <thead> <tr> <th>OPT</th> <th>FUNCTION</th> <th>DESCRIPTION</th> </tr> </thead> <tbody> <tr> <td>0</td> <td>MAS</td> <td>The equipment will make the functions of master in the network</td> </tr> <tr> <td>1</td> <td>SLV</td> <td>The equipment will act as a slave, taking orders of the master and transmitting its status</td> </tr> <tr> <td>2</td> <td>NON</td> <td>The equipment will be independent in the network, it hasn't slave or master function.</td> </tr> </tbody> </table>	OPT	FUNCTION	DESCRIPTION	0	MAS	The equipment will make the functions of master in the network	1	SLV	The equipment will act as a slave, taking orders of the master and transmitting its status	2	NON	The equipment will be independent in the network, it hasn't slave or master function.	NO
OPT	FUNCTION	DESCRIPTION														
0	MAS	The equipment will make the functions of master in the network														
1	SLV	The equipment will act as a slave, taking orders of the master and transmitting its status														
2	NON	The equipment will be independent in the network, it hasn't slave or master function.														

4.4.5.2. Subgroup S4.6.3 – Input O.F

Parameter / Default Value	Name / Description	Range	Function	Set on RUN												
5 CONTROL = 0	G4.6.3.5 / Control	0-2	<p>This parameter receives both the Start order and the Run status coming from the master. This status will be sent to the subgroups G4.1.1 and G4.1.2, allowing the slave to start with Start order or the Run status of the master.</p> <table border="1"> <thead> <tr> <th>OPT</th> <th>FUNCTION</th> <th>DESCRIPTION</th> </tr> </thead> <tbody> <tr> <td>0</td> <td>NONE</td> <td>The equipment will not take into account the START order or the RUN status. If we select FIBER in G4.1.1 or G4.1.2, the variable speed drive will not start.</td> </tr> <tr> <td>1</td> <td>START</td> <td>The Start order of the master will be sent to the FIBER option in the groups G4.1.1 and G4.1.2. It means that if we select the fiber option in the control mode while the master has a Start order, the slave will start.</td> </tr> <tr> <td>2</td> <td>RUN</td> <td>The RUN status of the master will be sent to the FIBER option in G4.1.1 and G4.1.2. When the fiber option is selected in a control mode and the master is in RUN, the slave will start and won't stop till the RUN has been disappeared of the master.</td> </tr> </tbody> </table>	OPT	FUNCTION	DESCRIPTION	0	NONE	The equipment will not take into account the START order or the RUN status. If we select FIBER in G4.1.1 or G4.1.2, the variable speed drive will not start.	1	START	The Start order of the master will be sent to the FIBER option in the groups G4.1.1 and G4.1.2. It means that if we select the fiber option in the control mode while the master has a Start order, the slave will start.	2	RUN	The RUN status of the master will be sent to the FIBER option in G4.1.1 and G4.1.2. When the fiber option is selected in a control mode and the master is in RUN, the slave will start and won't stop till the RUN has been disappeared of the master.	NO
OPT	FUNCTION	DESCRIPTION														
0	NONE	The equipment will not take into account the START order or the RUN status. If we select FIBER in G4.1.1 or G4.1.2, the variable speed drive will not start.														
1	START	The Start order of the master will be sent to the FIBER option in the groups G4.1.1 and G4.1.2. It means that if we select the fiber option in the control mode while the master has a Start order, the slave will start.														
2	RUN	The RUN status of the master will be sent to the FIBER option in G4.1.1 and G4.1.2. When the fiber option is selected in a control mode and the master is in RUN, the slave will start and won't stop till the RUN has been disappeared of the master.														
6 FAULT = 0	G4.6.3.6 / Control (Master)	0-1	<p>When this option is selected in the master drive and the system is working in closed ring mode, the master will STOP and show "F76 SLAVE O.F", if one or more slaves are faulted. Otherwise, the master will continue running.</p> <table border="1"> <thead> <tr> <th>OPT</th> <th>FUNCTION</th> </tr> </thead> <tbody> <tr> <td>0</td> <td>No</td> </tr> <tr> <td>1</td> <td>Yes</td> </tr> </tbody> </table>	OPT	FUNCTION	0	No	1	Yes	YES						
OPT	FUNCTION															
0	No															
1	Yes															
7 SPIN STP = 0	G4.6.3.7 / SPIN STOP (Slave)	0-1	<p>If we select this option, when the master will fault for any reason, all the slaves will stop automatically through a spin stop.</p> <table border="1"> <thead> <tr> <th>OPT</th> <th>FUNCTION</th> </tr> </thead> <tbody> <tr> <td>0</td> <td>No</td> </tr> <tr> <td>1</td> <td>Yes</td> </tr> </tbody> </table>	OPT	FUNCTION	0	No	1	Yes	NO						
OPT	FUNCTION															
0	No															
1	Yes															

4.4.5.3. Subgroup S4.6.5 – T/O F.O

Parameter / Default Value	Name / Description	Range	Function	Set on RUN										
5 T/O F.O = 0	G4.6.5/ Time out optical fiber (Slave)	OFF, 0.10 9.99	<p>Permits Open loop and close loop mode selection. Additionally for close loop mode, enable to establish the timeout response for slave. If the master does not receive response within the time selected the slave sets "F77 OPT FIB TO" fault.</p> <table border="1"> <thead> <tr> <th>OPT</th> <th>FUNCTION</th> </tr> </thead> <tbody> <tr> <td>OFF</td> <td>Close loop disable</td> </tr> <tr> <td>0.100s</td> <td>Close loop enable 0.1s</td> </tr> <tr> <td>....</td> <td></td> </tr> <tr> <td>9.990s</td> <td>Slave timeout response</td> </tr> </tbody> </table> <p>Otherwise, and also in the open loop, the option of "listener" slave is available. The slave only pays attention on the bus communications and does not make any action. This mode has been created to work with CANOpen and Devicenet boards</p>	OPT	FUNCTION	OFF	Close loop disable	0.100s	Close loop enable 0.1s		9.990s	Slave timeout response	NO
OPT	FUNCTION													
OFF	Close loop disable													
0.100s	Close loop enable 0.1s													
....														
9.990s	Slave timeout response													

4.5. Group 5 – G5: Acceleration and Deceleration Ramps

Parameter / Default Value	Name / Description	Range	Function	Set on RUN
1 ACC1=5.0%/s INITIAL ACCEL	G5.1 / Acceleration ramp 1	0.01 – 650% / sec	<p>Allows user to set acceleration ramp 1. The setting is in acceleration units (increase in percentage of speed per second). For example, a 10%/s ramp means that the drive increases its speed by 10% of motor rated speed for each second. This ramp will be set according to the requirements of each process.</p>	YES
2 DECEL1=1.0%/s INITIAL DECEL	G5.2 / Deceleration ramp 1	0.01 – 650% / sec	<p>Allows user to set deceleration ramp 1. The setting is in deceleration units (decrease in percentage of speed per second). For example, a 10%/s ramp means that the drive decreases its speed by 10% of motor rated speed for each second. This ramp will be set according to the requirements of each process.</p> <p>Note: For drives which input voltage is 400V, the default values will be:</p> <ul style="list-style-type: none"> - From 6A to 48A =10%/sec - From 60A to 170A =5%/sec - From 210A to I_{max} =2%/sec 	YES

Parameter / Default Value	Name / Description	Range	Function	Set on RUN
3 ACC2=10.0%/s SECOND ACCELE	G5.3 / Acceleration ramp 2	0.01 – 650% / sec	Allows user to set the alternative acceleration ramp. The setting is based in acceleration units (increase in percentage of speed per second), like the main ramp setting. The drive will apply acceleration ramp 1 until motor speed exceeds the value set in 'G5.5 BRK ACC'. From here on it will apply the alternative ramp value. If 'G5.5 BRK ACC = OFF' no ramp change will occur.	YES
4 DECEL2=10.0%/s SECOND DECELE	G5.4 / Deceleration ramp 2	0.01 – 650% / sec	Allows user to set the alternative deceleration ramp. The setting is in deceleration units (decrease in percentage of speed per second), like the main ramp setting. The drive will apply deceleration ramp 2 until motor speed is below the value set in 'G5.6 BRK DEC'. From here on it will apply the alternative ramp value. If 'G5.6 BRK DEC = OFF' no ramp change will occur. Note: For drives which input voltage is 400V, the default values will be: - From 6A to 48A =10%/sec - From 60A to 170A =5%/sec - From 210A to I _{max} =2%/sec	YES
5 BRK ACC=OFF BREAKPOINT ACL	G5.5 / Speed for acceleration ramp change	OFF, 0 to 250%	This parameter sets the break frequency for the alternative acceleration ramp. This parameter should be set at to the speed at which a change in the acceleration profile is required. If this value is exceeded the drive will start to apply the value of the alternative acceleration ramp. Note: Alternative acceleration and deceleration can be selected through the digital inputs or comparator output functions. This functionality is independent of the drive speed (for example, if the magnitude of the comparator is the drive rated current, when the drive output current exceeds a defined level, calculated as % of I _n , a ramp change occurs).	YES
6 BRK DEC=OFF BREAKPOINT DCL	G5.6 / Speed for deceleration ramp change	OFF, 0 to 250%	This parameter sets the break frequency for the alternative deceleration ramp. This parameter should be set at to the speed at which a change in the deceleration profile is required. If this value is exceeded, the drive will start to apply the value of the alternative deceleration ramp. Note: Alternative acceleration and deceleration can be selected as needed through the digital inputs or comparator output functions. This functionality is independent of the drive speed (for example, if the magnitude of the comparator is the drive rated current, when the drive output current is below a defined level, calculated as % of I _n , a ramp change occurs).	YES
7 MP I1=1.0%/s MOTO POT INC1	G5.7 / Ramp 1 of reference increase for motorized pot.	0.01 – 650% / sec	Allows adjustment of ramp 1 reference increase when using the motorized potentiometer function.	YES
8 MP D1=3.0%/s MOTO POT DEC1	G5.8 / Ramp 1 of reference decrease for motorized pot.	0.01 – 650% / sec	Allows adjustment of ramp 1 reference decrease when using the motorized potentiometer function.	YES
9 MP I2=1.0%/s MOTO POT INC2	G5.9 / Ramp 2 of reference increase for motorized potentiometer	0.01 – 650% / sec	Allows user to set the ramp 2 reference increase for the motorized potentiometer function. The drive will apply the ramp 1 rate until the value set in 'G5.11 PMOT BRK' is exceeded. From here on it will apply the alternative ramp value. If 'G5.11 PMOT BRK = OFF', no ramp change will occur.	YES
10 MP D2=3.0%/s MOTO POT DEC2	G5.10 / Ramp 2 of reference decrease for motorized potentiometer	0.01 – 650% / sec	Allows user to set the ramp 2 reference decrease for the motorized potentiometer function. The drive will apply the ramp 1 rate until below the value set in 'G5.11 PMOT BRK'. From here on it will apply the alternative ramp value. If 'G5.11 PMOT BRK = OFF', no ramp change will occur.	YES
11 MPOTBRK = OFF MOTO POT BRKPOIN	G5.11 / Speed for ramp change with motorized pot.	OFF=0 to 250%	This parameter sets the break frequency for the alternative acceleration and deceleration reference ramp when using motorized potentiometer. This parameter is the speed at which the change in motorized potentiometer reference ramp profile takes place.	YES
12 SP FLT= OFF SMOOT SPD FILTER	G5.12 / Time constant to filter the speed	OFF, 0.0 – 80.0%	Percentage of the acceleration ramp where the S - filter will be applied. S-Curve can be introduced if smoother performance during acceleration and deceleration is required. S-Curve introduces a filter for speed reference changes during 'Start/Stop' and acceleration and deceleration. It is especially useful in cranes and elevators.	YES

4.6. Group 6 – G6: PID Control

Parameter / Default Value	Name / Description	Range	Function	Set on RUN																								
1 SEL REF=MREF	G6.1 / Source selection for introducing reference signal	NONE AI1 AI2 RESERV MREF LOCAL LocPID COMMS	It allows user to select the reference source for the setpoint of the PID regulator. <table border="1"> <thead> <tr> <th>OPTION</th> <th>FUNCTION</th> </tr> </thead> <tbody> <tr> <td>NONE</td> <td>Source disabled.</td> </tr> <tr> <td>AI1</td> <td>PID setpoint introduced by Analogue Input 1.</td> </tr> <tr> <td>AI2</td> <td>PID setpoint introduced by Analogue Input 2.</td> </tr> <tr> <td>RESERV</td> <td>Reserved for future use.</td> </tr> <tr> <td>MREF</td> <td>PID setpoint introduced by Digital Inputs configured as Multi-references.</td> </tr> <tr> <td>LOCAL</td> <td>PID setpoint introduced by keypad. Value can be adjusted in screen 'G3.3 LOCAL SPD'.</td> </tr> <tr> <td>locPID</td> <td>PID setpoint introduced by keypad. Value is set in 'G6.2 PID LOC'. It allows user to have two speed references because 'G3.3 LOCAL SPD' is not modified.</td> </tr> <tr> <td>COMMS</td> <td>PID setpoint introduced by communications</td> </tr> </tbody> </table>	OPTION	FUNCTION	NONE	Source disabled.	AI1	PID setpoint introduced by Analogue Input 1.	AI2	PID setpoint introduced by Analogue Input 2.	RESERV	Reserved for future use.	MREF	PID setpoint introduced by Digital Inputs configured as Multi-references.	LOCAL	PID setpoint introduced by keypad. Value can be adjusted in screen 'G3.3 LOCAL SPD'.	locPID	PID setpoint introduced by keypad. Value is set in 'G6.2 PID LOC'. It allows user to have two speed references because 'G3.3 LOCAL SPD' is not modified.	COMMS	PID setpoint introduced by communications	NO						
OPTION	FUNCTION																											
NONE	Source disabled.																											
AI1	PID setpoint introduced by Analogue Input 1.																											
AI2	PID setpoint introduced by Analogue Input 2.																											
RESERV	Reserved for future use.																											
MREF	PID setpoint introduced by Digital Inputs configured as Multi-references.																											
LOCAL	PID setpoint introduced by keypad. Value can be adjusted in screen 'G3.3 LOCAL SPD'.																											
locPID	PID setpoint introduced by keypad. Value is set in 'G6.2 PID LOC'. It allows user to have two speed references because 'G3.3 LOCAL SPD' is not modified.																											
COMMS	PID setpoint introduced by communications																											
2 PID LOC=+100.0% ^[5] PID LOCAL SETPOI	G6.2 / PID local reference	+0.0% to +400%	When 'locPID' is set as setpoint source, the reference introduced by keypad will be memorized in this parameter. The value of the parameter 'G3.3 LOCAL SPD' is not modified and it is available if we want to use alternative speed reference.	YES																								
3 SEL FBK=AI2	G6.3 / Selection of feedback signal source	NONE AI1 AI2 AI1+AI2 COMMS MtrTrq AbsMTq Mtr l. MtrPwr BUSVdc PhiCos	To select the source of the feedback signal for the PID control loop. <table border="1"> <thead> <tr> <th>OPTION</th> <th>FUNCTION</th> </tr> </thead> <tbody> <tr> <td>NONE</td> <td>The PID function is not active</td> </tr> <tr> <td>AI1</td> <td>Feedback signal through the Analogue Input 1</td> </tr> <tr> <td>AI2</td> <td>Feedback signal through the Analogue Input 2</td> </tr> <tr> <td>AI1+AI2</td> <td>Feedback will be the addition of the signals introduced through the Analogue Inputs 1 and 2</td> </tr> <tr> <td>COMMS</td> <td>Feedback signal through communications</td> </tr> <tr> <td>MtrTrq</td> <td>Motor torque</td> </tr> <tr> <td>AbsMTq</td> <td>Absolute motor torque</td> </tr> <tr> <td>Mtr l.</td> <td>Motor output current</td> </tr> <tr> <td>MtrPwr</td> <td>Motor output power</td> </tr> <tr> <td>BUSVdc</td> <td>Bus voltage</td> </tr> <tr> <td>PhiCos</td> <td>Phi Cosine</td> </tr> </tbody> </table>	OPTION	FUNCTION	NONE	The PID function is not active	AI1	Feedback signal through the Analogue Input 1	AI2	Feedback signal through the Analogue Input 2	AI1+AI2	Feedback will be the addition of the signals introduced through the Analogue Inputs 1 and 2	COMMS	Feedback signal through communications	MtrTrq	Motor torque	AbsMTq	Absolute motor torque	Mtr l.	Motor output current	MtrPwr	Motor output power	BUSVdc	Bus voltage	PhiCos	Phi Cosine	NO
OPTION	FUNCTION																											
NONE	The PID function is not active																											
AI1	Feedback signal through the Analogue Input 1																											
AI2	Feedback signal through the Analogue Input 2																											
AI1+AI2	Feedback will be the addition of the signals introduced through the Analogue Inputs 1 and 2																											
COMMS	Feedback signal through communications																											
MtrTrq	Motor torque																											
AbsMTq	Absolute motor torque																											
Mtr l.	Motor output current																											
MtrPwr	Motor output power																											
BUSVdc	Bus voltage																											
PhiCos	Phi Cosine																											
4 GAIN Kp=8.0 PID PROPORTIONAL	G6.4 / Proportional gain of PID control	0.1 to 20	It allows setting the proportional gain value of the PID regulator. If you need a higher control response, increase this value. Note: If this value is increased too much, a higher instability in the system can be introduced.	YES																								
5 INTEGRAL = 0.1s PID INTEGRAL	G6.5 / Integration time of PID control	0.1 – 1000s, Max	It allows setting the integration time of the PID regulator. If you need a higher accuracy you should increase this value. Note: If this value is increased too much, the system can become slower.	YES																								
6 DIFFEREN = 0.0s PID DIFFERENTIAL	G6.6 / Derivation time of PID control	0.0 – 250s	It allows setting the derivate time of the PID regulator. If you need a higher response, you can increase this value. Note: If this value is increased too much, accuracy can decrease.	YES																								
7 INVERT PID=N	G6.7 / PID output inversion	N Y	It allows inverting the PID output of the drive. <table border="1"> <thead> <tr> <th>OPTION</th> <th>FUNCTION</th> </tr> </thead> <tbody> <tr> <td>N=NO</td> <td>PID regulator responds in normal mode, that means, when the feedback value is above the reference signal value, speed will be decreased. If the feedback value is below the reference signal value, speed will be increased.</td> </tr> <tr> <td>Y=YES</td> <td>PID regulator responds in inverse mode. So, when the feedback value is above the reference signal value, speed will be increased. If the feedback value is below the reference signal value, speed will be decreased.</td> </tr> </tbody> </table>	OPTION	FUNCTION	N=NO	PID regulator responds in normal mode, that means, when the feedback value is above the reference signal value, speed will be decreased. If the feedback value is below the reference signal value, speed will be increased.	Y=YES	PID regulator responds in inverse mode. So, when the feedback value is above the reference signal value, speed will be increased. If the feedback value is below the reference signal value, speed will be decreased.	NO																		
OPTION	FUNCTION																											
N=NO	PID regulator responds in normal mode, that means, when the feedback value is above the reference signal value, speed will be decreased. If the feedback value is below the reference signal value, speed will be increased.																											
Y=YES	PID regulator responds in inverse mode. So, when the feedback value is above the reference signal value, speed will be increased. If the feedback value is below the reference signal value, speed will be decreased.																											
8 Filt FB = OFF	G6.8 / Low pass filter	OFF, 0 to 20s	It allows setting the value of a low pass filter. It will be used to soften the feedback in the PID.	YES																								
9 ERR PID = +0.0%	G6.9 / PID control error	-400% to 400%	It shows the difference between the reference 'G6.1 SEL REF' and the feedback signal of the process 'G6.3 SEL FBK'.	YES																								

Note: PID functions will be set here if this function is enabled in the parameters 'G3.1 REF1 SPD=LOCAL' or 'G3.2 REF2 SPD=LOCAL'.

^[5] It will be available if 'G6.1 SEL REF = locPID'.

4.7. Group 7 – G7: Start / Stop Mode Configuration

Parameter / Default Value	Name / Description	Range	Function	Set on RUN								
1 STOP 1 = RAMP	G7.1 / Stop mode 1	RAMP SPIN	<p>It selects the main stop mode of the drive. This value should be configured appropriately for each application.</p> <table border="1"> <thead> <tr> <th>OPT</th> <th>FUNCTION</th> </tr> </thead> <tbody> <tr> <td>RAMP</td> <td>The drive will stop applying a frequency ramp to stop the motor. The rate of stop is determined in screen 'G5.2 Decel 1'</td> </tr> <tr> <td>SPIN</td> <td>The drive will turn off the output to the motor. The motor will coast to stop. Stopping time is determined by system inertia.</td> </tr> </tbody> </table>	OPT	FUNCTION	RAMP	The drive will stop applying a frequency ramp to stop the motor. The rate of stop is determined in screen 'G5.2 Decel 1'	SPIN	The drive will turn off the output to the motor. The motor will coast to stop. Stopping time is determined by system inertia.	YES		
OPT	FUNCTION											
RAMP	The drive will stop applying a frequency ramp to stop the motor. The rate of stop is determined in screen 'G5.2 Decel 1'											
SPIN	The drive will turn off the output to the motor. The motor will coast to stop. Stopping time is determined by system inertia.											
2 STOP 2 = SPIN	G7.2 / Stop mode 2	RAMP SPIN	<p>User can select an alternative stop mode of the drive if required. For options information see parameter 'G7.1 STOP 1=RAMP'. Note: Stop mode 1 or 2 can be selected by digital inputs, by comparator output functions, or by setting a changing speed for stop mode in 'G7.3 BRK STP 2'.</p>	YES								
3 BRK STP 2 = OFF STP2 UNDER SPEED	G7.3 / Changing speed for stop mode	OFF=0 to 250%	<p>When this parameter is set to a value other than zero a second stopping profile can be activated based on motor speed. When the drive receives a stop mode 1 command, it will stop from steady status to the speed set here. At that moment, the drive will apply stop mode 2 to complete the stop. Note: Stop mode 1 or 2 can be selected by digital inputs, by comparator output functions, or by setting a changing speed for stop mode in 'G7.3 BRK STP 2'.</p>	YES								
4 START = RAMP	G7.4 / Start mode	RAMP SPIN SPIN2	<p>It selects the start mode of the drive. This value should be configured appropriately for each application.</p> <table border="1"> <thead> <tr> <th>OPT</th> <th>FUNCTION</th> </tr> </thead> <tbody> <tr> <td>RAMP</td> <td>Drive will start applying a frequency ramp to the motor.</td> </tr> <tr> <td>SPIN</td> <td>In this mode, the motor shaft speed is automatically searched for and the frequency output of the drive is set to match the actual motor speed. From this point the motor is then accelerated normally up to the reference speed. This allows starting loads that are still rotating when the drive receives a start command. Note: This option is valid when the motor is running at positive rotation direction.</td> </tr> <tr> <td>SPIN2</td> <td>Operates similar than the option 'SPIN'. The difference lies in the possibility of starting loads that are still rotating independently of the rotation direction of the motor.</td> </tr> </tbody> </table> <p>Note: Start mode 2 (alternative start mode) is selected through a digital input configured with option '22 → START MODE 2'.</p>	OPT	FUNCTION	RAMP	Drive will start applying a frequency ramp to the motor.	SPIN	In this mode, the motor shaft speed is automatically searched for and the frequency output of the drive is set to match the actual motor speed. From this point the motor is then accelerated normally up to the reference speed. This allows starting loads that are still rotating when the drive receives a start command. Note: This option is valid when the motor is running at positive rotation direction.	SPIN2	Operates similar than the option 'SPIN'. The difference lies in the possibility of starting loads that are still rotating independently of the rotation direction of the motor.	YES
OPT	FUNCTION											
RAMP	Drive will start applying a frequency ramp to the motor.											
SPIN	In this mode, the motor shaft speed is automatically searched for and the frequency output of the drive is set to match the actual motor speed. From this point the motor is then accelerated normally up to the reference speed. This allows starting loads that are still rotating when the drive receives a start command. Note: This option is valid when the motor is running at positive rotation direction.											
SPIN2	Operates similar than the option 'SPIN'. The difference lies in the possibility of starting loads that are still rotating independently of the rotation direction of the motor.											
5 START 2=RAMP	G7.5 / Start mode 2	RAMP SPIN SPIN2	<p>Note: Start mode 2 (alternative start mode) is selected through a digital input configured with option '22 → START MODE 2'.</p>	YES								
6 STAR DLY = OFF DELAY TO START	G7.6 / Start delay time	OFF=0 to 6500s	<p>Allows setting of a delay time from the moment the drive receives the start command to the beginning of providing an output frequency to the motor. Note: After receiving the start command, the drive will wait until the delay time is elapsed. During this time, the drive status will change to 'DLY'.</p>	YES								
7 STOP DLY = OFF DELAY TO STOP	G7.7 / Stop delay time	OFF=0 to 6500s	<p>Allows setting of a delay time applied from the moment the drive receives the stop command until the drive stops providing an output frequency to the motor.</p>	YES								

Parameter / Default Value	Name / Description	Range	Function	Set on RUN32						
8 STP MIN SP = N	G7.8 / Minimum stop speed	N Y	<p>Allows user to stop the motor when the speed is below the SD700 lower speed limit.</p> <table border="1"> <thead> <tr> <th>OPT</th> <th>FUNCTION</th> </tr> </thead> <tbody> <tr> <td>N=NO</td> <td>In this case, the motor will continue to operate at minimum speed defined as minimum speed limit (set in G10.1 or G10.3), even if the speed reference is below these settings. For example, if '1 MIN1 SP=+30.00%', and the speed reference is +20.00%, the equipment will operate at +30.00%, and never below this value.</td> </tr> <tr> <td>Y=YES</td> <td>In this case, the drive will automatically start when the speed reference is above the value set as minimum speed limit. While the speed reference is below this value, equipment will be in 'READY' status. If the drive is decelerating and the reference is below the minimum speed value, then the equipment will stop by spin.</td> </tr> </tbody> </table> <p>Note: If you want to stop the motor when the reference is below a fixed speed setpoint, you should set this parameter to YES. Additionally, you should set the correct values in 'G10.1 MIN1 SP' or 'G10.3 MIN2 SP'.</p>	OPT	FUNCTION	N=NO	In this case, the motor will continue to operate at minimum speed defined as minimum speed limit (set in G10.1 or G10.3), even if the speed reference is below these settings. For example, if '1 MIN1 SP=+30.00%', and the speed reference is +20.00%, the equipment will operate at +30.00%, and never below this value.	Y=YES	In this case, the drive will automatically start when the speed reference is above the value set as minimum speed limit. While the speed reference is below this value, equipment will be in 'READY' status. If the drive is decelerating and the reference is below the minimum speed value, then the equipment will stop by spin.	YES
OPT	FUNCTION									
N=NO	In this case, the motor will continue to operate at minimum speed defined as minimum speed limit (set in G10.1 or G10.3), even if the speed reference is below these settings. For example, if '1 MIN1 SP=+30.00%', and the speed reference is +20.00%, the equipment will operate at +30.00%, and never below this value.									
Y=YES	In this case, the drive will automatically start when the speed reference is above the value set as minimum speed limit. While the speed reference is below this value, equipment will be in 'READY' status. If the drive is decelerating and the reference is below the minimum speed value, then the equipment will stop by spin.									
9 OFFdly = OFF DELAY AFTER STOP	G7.9 / Delay time between stop and next start	OFF=0.000 to 10.0s	Allows setting a delay time between the moment the drive has stopped and the next starting. The next time the drive has to start it will consider no additional delay time unless parameter 'G7.6 START DLY' had been set to a value different from OFF.	YES						
10 RUN AFTR VFL = N	G7.10 K/ Run after occurring power loss	N Y	<p>Allows setting of the drive to start automatically when a main power supply loss occurs and it is recovered again (power supply loss or instant power supply loss).</p> <table border="1"> <thead> <tr> <th>OPT</th> <th>FUNCTION</th> </tr> </thead> <tbody> <tr> <td>N=NO</td> <td>The drive will not start after power supply recovery occurs even the start command is active. User should deactivate this signal and activate it again.</td> </tr> <tr> <td>Y=YES</td> <td>The drive starts automatically when power supply is recovered after power supply loss occurs and if the start signal is active.</td> </tr> </tbody> </table> <p>Note: If start / stop control is done by keypad, the drive will not start automatically after power supply loss occurs and it is recovered again.</p>	OPT	FUNCTION	N=NO	The drive will not start after power supply recovery occurs even the start command is active. User should deactivate this signal and activate it again.	Y=YES	The drive starts automatically when power supply is recovered after power supply loss occurs and if the start signal is active.	YES
OPT	FUNCTION									
N=NO	The drive will not start after power supply recovery occurs even the start command is active. User should deactivate this signal and activate it again.									
Y=YES	The drive starts automatically when power supply is recovered after power supply loss occurs and if the start signal is active.									
11 SPNstr B = OFF SPIN START TUNE	G7.11 / Accuracy setting for Starting by Spin	OFF=0; 1 to 10%	It allows setting the accuracy of the speed searching function when the drive starts by SPIN mode. Usually, the optimum value is between 2 and 5%. As the value is lower, more accuracy is required.	YES						
12 OFFdly2=OFF DELAY AFTER STP2	G7.12 / Delay time for start command after stop	OFF=0, 0.1 to 6500.0min	Delay time for start command after producing a stop. If the start command is given after the time set in this parameter has elapsed, the drive will start immediately.	YES						
13 RUN AFT RST=N	G7.13 / Start after fault reset with start command	N Y	<p>It allows starting the drive after resetting the fault produced in the equipment, whenever the start command is activated.</p> <table border="1"> <thead> <tr> <th>OPT.</th> <th>FUNCTION</th> </tr> </thead> <tbody> <tr> <td>N=NO</td> <td>After resetting the fault, the drive will not start although the start command is activated. To start, the user should deactivate the start command and activate it again. This operation mode guarantees a starting controlled by an operator although the fault is reset. This option is commonly used in remote controls in order to increase the safety at the starting.</td> </tr> <tr> <td>Y=YES</td> <td>The drive will start after resetting the fault, whenever the start command is activated.</td> </tr> </tbody> </table>	OPT.	FUNCTION	N=NO	After resetting the fault, the drive will not start although the start command is activated. To start, the user should deactivate the start command and activate it again. This operation mode guarantees a starting controlled by an operator although the fault is reset. This option is commonly used in remote controls in order to increase the safety at the starting.	Y=YES	The drive will start after resetting the fault, whenever the start command is activated.	YES
OPT.	FUNCTION									
N=NO	After resetting the fault, the drive will not start although the start command is activated. To start, the user should deactivate the start command and activate it again. This operation mode guarantees a starting controlled by an operator although the fault is reset. This option is commonly used in remote controls in order to increase the safety at the starting.									
Y=YES	The drive will start after resetting the fault, whenever the start command is activated.									
14 Dpwr OFF = OFF	G7.14 / Power Off delay	OFF, 0.001 to 9.99s	Sets the time period during which the drive maintains the magnetic flux in the motor after reaching zero speed when stopping.	YES						
15 MagneT = OFF	G7.15 / Magnetization Time	OFF, 0.001 to 9.99s	Sets the period of time during which the motor is being magnetized before the start.	YES						
16 DL SAR= 0.01s	G7.16 /DLY Start after Run.	OFF, 0.001 to 9.99s	Operates with G7.13. Estimates the minimum time that the start order has to be disabled before starting after the reset.	YES						

4.8. Group 8 – G8: Outputs

4.8.1. Subgroup 8.1 – S8.1: Output Relays

Parameter / Default Value	Name / Description	Range	Function	Set on RUN																																																																																							
1 SEL RELAY 1=02	G8.1.1 / Selection of Relay 1 control source	00 – 45	It configures the operation of each output relay according to the options shown in the following table:	NO																																																																																							
			<table border="1"> <thead> <tr> <th>OPT</th> <th>DESCRIPTION</th> <th>FUNCTION</th> </tr> </thead> <tbody> <tr> <td>00</td> <td>ALWAYS OFF</td> <td>Output is not active.</td> </tr> <tr> <td>01</td> <td>ALWAYS ON</td> <td>When the drive is powered the output relay is activated.</td> </tr> <tr> <td>02</td> <td>NO FAULTS</td> <td>There is no fault in the drive. When a fault occurs, the relay will be activated.</td> </tr> <tr> <td>03</td> <td>GENERAL FAULT</td> <td>Drive fault or low input voltage will activate the relay.</td> </tr> <tr> <td>04</td> <td>START</td> <td>Relay is active when the drive has received the start command.</td> </tr> <tr> <td>05</td> <td>RUN</td> <td>The relay will be energized after the drive is started (the speed is increasing). i.e. G8.1.1 = 04 and G8.1.2 = 05. Start command is on, relay 1 is on and immediately relay 2 is on. Stop command is activated, then relay 1 is automatically off BUT relay 2 will be on until drive was completely stopped.</td> </tr> <tr> <td>06</td> <td>READY</td> <td>Drive is ready for start (no fault and no warning).</td> </tr> <tr> <td>07</td> <td>ZERO SPEED</td> <td>Drive is running at zero speed.</td> </tr> <tr> <td>08</td> <td>SET SPEED</td> <td>Speed has reached the value set as reference.</td> </tr> <tr> <td>09</td> <td>SP DIRECTION</td> <td>The relay is activated when the speed direction is negative.</td> </tr> <tr> <td>10</td> <td>RESERVE</td> <td>Reserved for future use.</td> </tr> <tr> <td>11</td> <td>SP REF DIRECT</td> <td>The relay is activated when the speed refer. direction is negative.</td> </tr> <tr> <td>12</td> <td>RESERVE</td> <td>Reserved for future use.</td> </tr> <tr> <td>13</td> <td>SP LIMIT</td> <td>Speed limit has been reached.</td> </tr> <tr> <td>14</td> <td>CURR LIMIT</td> <td>Motor current limit has been reached.</td> </tr> <tr> <td>15</td> <td>VOLT LIMIT</td> <td>DC Bus voltage limit has been reached.</td> </tr> <tr> <td>16</td> <td>TORQ LIMIT</td> <td>Torque limit has been reached.</td> </tr> <tr> <td>17</td> <td>COMPARATOR1</td> <td>When the comparator 1 output is active, relay is activated.</td> </tr> <tr> <td>18</td> <td>COMPARATOR2</td> <td>When the comparator 2 is output active, relay is activated.</td> </tr> <tr> <td>19</td> <td>COMPARATOR3</td> <td>When the comparator 3 output is active, relay is activated.</td> </tr> <tr> <td>20</td> <td>ACC / DEC 2</td> <td>Relay is activated if the alternative ramps are used.</td> </tr> <tr> <td>21</td> <td>REFERENCE 2</td> <td>Relay is activated if reference 2 has been selected.</td> </tr> <tr> <td>22</td> <td>STOP 2</td> <td>Relay is activated if stop mode 2 is used.</td> </tr> <tr> <td>23</td> <td>SP LIMIT 2</td> <td>Relay is activated if the alternative speed limits have been selected.</td> </tr> <tr> <td>24</td> <td>DC BRAKE</td> <td>Relay is activated if DC brake is active.</td> </tr> <tr> <td>25</td> <td>RESERVE</td> <td>Reserved for future use.</td> </tr> <tr> <td>26</td> <td>RESERVE</td> <td>Reserved for future use.</td> </tr> <tr> <td>27</td> <td>RESERVE</td> <td>Reserved for future use.</td> </tr> </tbody> </table>		OPT	DESCRIPTION	FUNCTION	00	ALWAYS OFF	Output is not active.	01	ALWAYS ON	When the drive is powered the output relay is activated.	02	NO FAULTS	There is no fault in the drive. When a fault occurs, the relay will be activated.	03	GENERAL FAULT	Drive fault or low input voltage will activate the relay.	04	START	Relay is active when the drive has received the start command.	05	RUN	The relay will be energized after the drive is started (the speed is increasing). i.e. G8.1.1 = 04 and G8.1.2 = 05. Start command is on, relay 1 is on and immediately relay 2 is on. Stop command is activated, then relay 1 is automatically off BUT relay 2 will be on until drive was completely stopped.	06	READY	Drive is ready for start (no fault and no warning).	07	ZERO SPEED	Drive is running at zero speed.	08	SET SPEED	Speed has reached the value set as reference.	09	SP DIRECTION	The relay is activated when the speed direction is negative.	10	RESERVE	Reserved for future use.	11	SP REF DIRECT	The relay is activated when the speed refer. direction is negative.	12	RESERVE	Reserved for future use.	13	SP LIMIT	Speed limit has been reached.	14	CURR LIMIT	Motor current limit has been reached.	15	VOLT LIMIT	DC Bus voltage limit has been reached.	16	TORQ LIMIT	Torque limit has been reached.	17	COMPARATOR1	When the comparator 1 output is active, relay is activated.	18	COMPARATOR2	When the comparator 2 is output active, relay is activated.	19	COMPARATOR3	When the comparator 3 output is active, relay is activated.	20	ACC / DEC 2	Relay is activated if the alternative ramps are used.	21	REFERENCE 2	Relay is activated if reference 2 has been selected.	22	STOP 2	Relay is activated if stop mode 2 is used.	23	SP LIMIT 2	Relay is activated if the alternative speed limits have been selected.	24	DC BRAKE	Relay is activated if DC brake is active.	25	RESERVE	Reserved for future use.	26	RESERVE	Reserved for future use.	27	RESERVE	Reserved for future use.
			OPT		DESCRIPTION	FUNCTION																																																																																					
			00		ALWAYS OFF	Output is not active.																																																																																					
			01		ALWAYS ON	When the drive is powered the output relay is activated.																																																																																					
			02		NO FAULTS	There is no fault in the drive. When a fault occurs, the relay will be activated.																																																																																					
			03		GENERAL FAULT	Drive fault or low input voltage will activate the relay.																																																																																					
			04		START	Relay is active when the drive has received the start command.																																																																																					
			05		RUN	The relay will be energized after the drive is started (the speed is increasing). i.e. G8.1.1 = 04 and G8.1.2 = 05. Start command is on, relay 1 is on and immediately relay 2 is on. Stop command is activated, then relay 1 is automatically off BUT relay 2 will be on until drive was completely stopped.																																																																																					
			06		READY	Drive is ready for start (no fault and no warning).																																																																																					
			07		ZERO SPEED	Drive is running at zero speed.																																																																																					
			08		SET SPEED	Speed has reached the value set as reference.																																																																																					
			09		SP DIRECTION	The relay is activated when the speed direction is negative.																																																																																					
			10		RESERVE	Reserved for future use.																																																																																					
			11		SP REF DIRECT	The relay is activated when the speed refer. direction is negative.																																																																																					
			12		RESERVE	Reserved for future use.																																																																																					
			13		SP LIMIT	Speed limit has been reached.																																																																																					
			14		CURR LIMIT	Motor current limit has been reached.																																																																																					
			15		VOLT LIMIT	DC Bus voltage limit has been reached.																																																																																					
			16		TORQ LIMIT	Torque limit has been reached.																																																																																					
			17		COMPARATOR1	When the comparator 1 output is active, relay is activated.																																																																																					
			18		COMPARATOR2	When the comparator 2 is output active, relay is activated.																																																																																					
			19		COMPARATOR3	When the comparator 3 output is active, relay is activated.																																																																																					
			20		ACC / DEC 2	Relay is activated if the alternative ramps are used.																																																																																					
			21		REFERENCE 2	Relay is activated if reference 2 has been selected.																																																																																					
			22		STOP 2	Relay is activated if stop mode 2 is used.																																																																																					
			23		SP LIMIT 2	Relay is activated if the alternative speed limits have been selected.																																																																																					
			24		DC BRAKE	Relay is activated if DC brake is active.																																																																																					
25	RESERVE	Reserved for future use.																																																																																									
26	RESERVE	Reserved for future use.																																																																																									
27	RESERVE	Reserved for future use.																																																																																									
Note: See following page.																																																																																											

Parameter / Default Value	Name / Description	Range	Function	Set on RUN																																					
1 SEL RELAY 1=02	G8.1.1 / Selection of Relay 1 control source	00 – 45	Note: Coming from the previous page.	NO																																					
			<table border="1"> <thead> <tr> <th>OPT</th> <th>DESCRIPTION</th> <th>FUNCTION</th> </tr> </thead> <tbody> <tr> <td>32</td> <td>CRANE BRAKE</td> <td>The relay will be activated like in option "05 RUN", considering the ON delay time set in G8.1.2, G8.1.6 or G8.1.10 (depending on the used Relay 1, 2 or 3), and will be deactivated when the motor speed is below the speed set in G8.1.13.</td> </tr> <tr> <td>33</td> <td>PIPE FILLING</td> <td>In pump application the relay is energized when the application state is pipe filling.</td> </tr> <tr> <td>34</td> <td>WARNING</td> <td>The relay is energized when there is any Warning.</td> </tr> <tr> <td>35</td> <td>COPY DI1</td> <td rowspan="5">Copies the corresponding digital input and closes the relay when the digital input is active.</td> </tr> <tr> <td>36</td> <td>COPY DI2</td> </tr> <tr> <td>37</td> <td>COPY DI3</td> </tr> <tr> <td>38</td> <td>COPY DI4</td> </tr> <tr> <td>39</td> <td>COPY DI5</td> </tr> <tr> <td>40</td> <td>COPY DI6</td> </tr> <tr> <td>41</td> <td>F40 PTC</td> <td>If this option is selected in one digital output, when the drive trips by the F40 PTC EXT, the digital output will change the status.</td> </tr> <tr> <td>42</td> <td>FAULT1</td> <td rowspan="4">It will be active when the respective fault configured in G8.1 group FAULTX is raised in the drive.</td> </tr> <tr> <td>43</td> <td>FAULT2</td> </tr> <tr> <td>44</td> <td>FAULT3</td> </tr> <tr> <td>45</td> <td>FAULT4</td> </tr> </tbody> </table>		OPT	DESCRIPTION	FUNCTION	32	CRANE BRAKE	The relay will be activated like in option "05 RUN", considering the ON delay time set in G8.1.2, G8.1.6 or G8.1.10 (depending on the used Relay 1, 2 or 3), and will be deactivated when the motor speed is below the speed set in G8.1.13.	33	PIPE FILLING	In pump application the relay is energized when the application state is pipe filling.	34	WARNING	The relay is energized when there is any Warning.	35	COPY DI1	Copies the corresponding digital input and closes the relay when the digital input is active.	36	COPY DI2	37	COPY DI3	38	COPY DI4	39	COPY DI5	40	COPY DI6	41	F40 PTC	If this option is selected in one digital output, when the drive trips by the F40 PTC EXT, the digital output will change the status.	42	FAULT1	It will be active when the respective fault configured in G8.1 group FAULTX is raised in the drive.	43	FAULT2	44	FAULT3	45	FAULT4
			OPT		DESCRIPTION	FUNCTION																																			
			32		CRANE BRAKE	The relay will be activated like in option "05 RUN", considering the ON delay time set in G8.1.2, G8.1.6 or G8.1.10 (depending on the used Relay 1, 2 or 3), and will be deactivated when the motor speed is below the speed set in G8.1.13.																																			
			33		PIPE FILLING	In pump application the relay is energized when the application state is pipe filling.																																			
			34		WARNING	The relay is energized when there is any Warning.																																			
			35		COPY DI1	Copies the corresponding digital input and closes the relay when the digital input is active.																																			
			36		COPY DI2																																				
			37		COPY DI3																																				
			38		COPY DI4																																				
			39		COPY DI5																																				
40	COPY DI6																																								
41	F40 PTC	If this option is selected in one digital output, when the drive trips by the F40 PTC EXT, the digital output will change the status.																																							
42	FAULT1	It will be active when the respective fault configured in G8.1 group FAULTX is raised in the drive.																																							
43	FAULT2																																								
44	FAULT3																																								
45	FAULT4																																								
2 T R1 ON=0.0s R1 ACTIVAT DELAY	G8.1.2 / ON delay time for Relay 1	0.0 – 999s	Allows user to set a delay time before activating relay 1. If during this ON delay time the activation condition disappears, the relay will not be activated.	YES																																					
3 T R1 OFF=0.0s R1 DEACTIV DELAY	G8.1.3 / OFF delay time for Relay 1	0.0 – 999s	Allows user to set a delay time before deactivating relay 1. If during this OFF delay time the deactivation condition disappears, the relay will follow activated.	YES																																					
4 INVERT REL1=N	G8.1.4 / Relay 1 inversion	N Y	It allows user to invert the logic of relay 1 functionality. Relay 1 has one normally open contact (connection 26/27) and another normally close contact (connection 27/28). <table border="1"> <thead> <tr> <th>OPT</th> <th>FUNCTION</th> </tr> </thead> <tbody> <tr> <td>N=NO</td> <td>No inversion.</td> </tr> <tr> <td>Y=YES</td> <td>Inversion of relay logical function.</td> </tr> </tbody> </table>	OPT	FUNCTION	N=NO	No inversion.	Y=YES	Inversion of relay logical function.	NO																															
OPT	FUNCTION																																								
N=NO	No inversion.																																								
Y=YES	Inversion of relay logical function.																																								
5 SEL RELAY 2=03	G8.1.5 / Selection of Relay 2 control source	00 – 45	Note: See parameter function of G8.1.1.	NO																																					
6 T R2 ON=0.0s R2 ACTIVAT DELAY	G8.1.6 / ON delay time for Relay 2	0.0 – 999s	Allows user to set a delay time before activating relay 2. If during this ON delay time the activation condition disappears, the relay will not be activated.	YES																																					
7 T R2 OFF=0.0s R2 DEACTIV DELAY	G8.1.7 / OFF delay time for Relay 2	0.0 – 999s	Allows user to set a delay time before deactivating relay 2. If during this OFF delay time the deactivation condition disappears, the relay will follow activated.	YES																																					
8 INVERT REL2=N	G8.1.8 / Relay 2 inversion	N Y	It allows user to invert the logic of relay 2 functionality. Relay 2 has one normally open contact (connection 29/30) and another normally close contact (connection 30/31). <table border="1"> <thead> <tr> <th>OPT</th> <th>FUNCTION</th> </tr> </thead> <tbody> <tr> <td>N=NO</td> <td>No inversion.</td> </tr> <tr> <td>Y=YES</td> <td>Inversion of relay logical function.</td> </tr> </tbody> </table>	OPT	FUNCTION	N=NO	No inversion.	Y=YES	Inversion of relay logical function.	NO																															
OPT	FUNCTION																																								
N=NO	No inversion.																																								
Y=YES	Inversion of relay logical function.																																								
9 SEL RELAY 3=05	G8.1.9 / Selection of Relay 3 control source	00 – 45	Note: See parameter function of G8.1.1.	NO																																					
10 T R3 ON=0.0s R3 ACTIVAT DELAY	G8.1.10 / ON delay time for Relay 3	0.0 – 999s	Allows user to set a delay time before activating relay 3. If during this ON delay time the activation condition disappears, the relay will not be activated.	YES																																					
11 T R3 OFF=0.0s R3 DEACTIV DELAY	G8.1.11 / OFF delay time for Relay 3	0.0 – 999s	Allows user to set a delay time before deactivating relay 3. If during this OFF delay time the deactivation condition disappears, the relay will follow activated.	YES																																					

Parameter / Default Value	Name / Description	Range	Function	Set on RUN										
12 INVERT REL3=N	G8.1.12 / Relay 3 inversion	N Y	<p>It allows user to invert the logic of relay 3 functionality. Relay 3 has one normally open contact (connection 32/33) and another normally close contact (connection 33/34).</p> <table border="1"> <thead> <tr> <th>OPT</th> <th>FUNCTION</th> </tr> </thead> <tbody> <tr> <td>N=NO</td> <td>No inversion.</td> </tr> <tr> <td>Y=YES</td> <td>Inversion of relay logical function.</td> </tr> </tbody> </table>	OPT	FUNCTION	N=NO	No inversion.	Y=YES	Inversion of relay logical function.	NO				
OPT	FUNCTION													
N=NO	No inversion.													
Y=YES	Inversion of relay logical function.													
13 CRASpdOF=+5.0% CRANE BRKoff SPD	G8.1.13 / Speed for disconnecting relay in option Crane	+0.0% to +250%	This parameter allows setting the speed below which, any relay configured with option '32 CRANE BRAKE' will be deactivated.	YES										
34 Dig Out FB = DO1	G8.1.34 / Digital Output Feedback	DO1 DO2 DO3	This parameter allows setting the digital output that will be associated to the feedback functionality. When the digital input option "Dig Output FB" is set, its functionality is associated to the digital output set in this parameter. If the time between the activation of the digital output and the digital input exceeds the time adjusted in the parameter "G8.1.35 DlyDoFB", the drive trips by fault F55.	YES										
35 DlyDoFB = 1.0s	G8.1.35 / Delay Digital Output Feedback	0.5 to 60.0s	It allows setting the maximum time that the digital input configured as "Dig Output FB" will wait the feedback of the digital output set in G8.1.34 before tripping the drive by fault 55.	YES										
36 FAULT1 = OFF	G8.1.36 / Closure of digital output "FAULT1"	0 - 90	<p>It allows setting the fault (OFF, F1, F2..., F90) which will close the digital input configured as FAULT1, FAULT2, FAULT3 and FAULT4.</p> <table border="1"> <thead> <tr> <th>OPT</th> <th>DESCRIPTION</th> </tr> </thead> <tbody> <tr> <td>0</td> <td>OFF</td> </tr> <tr> <td>1</td> <td>F1</td> </tr> <tr> <td>....</td> <td>...</td> </tr> <tr> <td>90</td> <td>F90</td> </tr> </tbody> </table>	OPT	DESCRIPTION	0	OFF	1	F1	90	F90	YES
OPT	DESCRIPTION													
0	OFF													
1	F1													
....	...													
90	F90													
37 FAULT2 = OFF	G8.1.37 / Closure of digital output "FAULT2"	0 - 90												
38 FAULT3 = OFF	G8.1.38 / Closure of digital output "FAULT3"	0 - 90												
39 FAULT4 = OFF	G8.1.39 / Closure of digital output "FAULT4"	0 - 90												

4.8.2. Subgroup 8.2 – S8.2: Analogue Outputs

Parameter / Default Value	Name / Description	Range	Function	Set on RUN			
1 ANLG OUT1=01	G8.2.1 / Mode selection for Analogue Output 1	00 – 27	Analogue output is programmable according to the following table:		NO		
			OPT	DESCR.		FUNCTION	UNITS
			00	NONE		It is not used.	-
			01	SPEED MOTOR		Signal proportional to the motor speed.	% Motor speed
			02	CURRENT MOTOR		Signal proportional to the motor current.	% Motor rated current
			03	VOLTAGE MOTOR		Signal proportional to the motor voltage.	% Motor rated voltage
			04	POWER MOTOR		Signal proportional to the motor power.	% Motor power
			05	TORQUE MOTOR		Signal proportional to the motor torque.	% Motor torque
			06	PF MOTOR		Signal proportional to the motor power factor.	% Motor rated Cosine Phi
			07	TEMP MOTOR		Signal proportional to the motor temperature.	% Motor temperature
			08	FREQUENCY MTR		Signal proportional to the output frequency.	% Input frequency (50Hz=100%)
			09	INPUT VOLTAGE		Signal proportional to the input voltage.	% Equipment rated voltage
			10	DC BUS		Signal proportional to the DC Bus voltage.	% Motor voltage x 1.414
			11	DRIVE TEMP		Signal proportional to the drive temperature.	% Drive temperature
			12	SPEED REF		Signal proportional to the speed reference.	% Motor speed
			13	Reserved		Reserved for future use.	
			14	PID REFERENCE		Signal proportional to the reference in PID mode.	%
			15	PID FEEDBACK		Signal proportional to the feedback in PID mode.	%
			16	PID ERROR		Signal proportional to the error (difference between reference and feedback) in PID mode.	%
			17	ANLG INPUT 1		Analogue input 1 signal is transferred to analogue output.	%
			18	ANLG INPUT 2		Analogue input 2 signal is transferred to analogue output.	%
			19	ANLG INPUT1+2		The average of the analog inputs 1 and 2.	%
			20	CURRENT FLOW		Analogue signal proportional to the read flow through analogue input or pulse input.	%
			21	MAX SCALE		It forces the output to maximum value.	100% bottom scale
			22	ABSOLUT SPEED		Signal proportional to the motor speed without sign (absolute value).	% Motor speed
23	ABSOLUT TORQUE	Signal proportional to the motor torque without sign (absolute value).	% Motor torque				
24	ENCODER SPD	Signal proportional to the real speed of the encoder	% rpm (motor nameplate)				
2 FORMT 1=4-20 mA	G8.2.2 / Format selection for Analogue Output 1	0-10V ±10V 0-20mA 4-20mA	Analogue output 1 is programmable in one of four possible formats according to the system requirements.	NO			

Parameter / Default Value	Name / Description	Range	Function	Set on RUN
3 MIN1 RNG=+0% MIN RANG ANAOUT1	G8.2.3 / Low of range selection Analogue Output 1	-250% to +250%	Minimum level of analogue output 1. Minimum level setting can be higher than the maximum level setting. This allows the user to achieve inverse scaling. i.e. an increase in magnitude of the analogue input would result in an output frequency decrease and vice versa.	YES
4 MAX1 RNG=+100% MAX RANG ANAOUT1	G8.2.4 / High range selection of Analogue Output 1	-250% to +250%	Maximum level of analogue output 1. Maximum level setting can be lower than the minimum level setting. This allows the user to achieve inverse scaling. i.e. an increase in magnitude of the analogue input would result in an output frequency decrease and vice versa.	YES
5 FILTER 1=OFF FILTER ANAOUTPU1	G8.2.5 / Filter selection for Analogue Output 1	OFF=0.0 to 20.0s	Filter for analogue input 1 value. If the analogue signal appears slightly unstable, improved stability and response can be achieved with the addition of a suitable filter value. Note: Filter use can add a slight delay to the analogue output signal.	YES
6 ANLG OUT 2=02	G8.2.6 / Mode selection Analogue Output 2	00 – 27	Analogue output 2 is programmable. See parameter 'G8.2.1 ANLG OUT 1' for options table.	NO
7 FORMT 2=4-20 mA	G8.2.7 / Format selection for Analogue Output 2	0-10V, ±10V, 0-20mA, 4-20mA.	Analogue output 2 is programmable in one of four possible formats according to the system requirements.	NO
8 MIN2 RNG=+0% MIN RANG ANAOUT2	G8.2.8 / Low range selection of Analogue Output 2	-250% to +250%	Minimum level of analogue output 2. Minimum level setting can be higher than the maximum level. This allows the user to achieve inverse scaling. i.e. an increase in magnitude of the analogue input would result in an output frequency decrease and vice versa.	YES
9 MAX2 RNG=+100% MAX RANG ANAOUT2	G8.2.9 / High range selection of Analogue Output 2	-250% to 250%	Maximum level of analogue output 2. Maximum level setting can be lower than the minimum level. This allows the user to achieve inverse scaling. i.e. an increase in magnitude of the analogue input would result in an output frequency decrease and vice versa.	YES
10 FILTER 2=OFF FILTER ANAOUTPU2	G8.2.10 / Filter selection for Analogue Output 2	OFF=0.0 to 20.0s	Filter for analogue output 2 value. If the analogue signal appears slightly unstable improved stability and response can be achieved with the addition of a suitable filter value. Note: Filter use can add a slight delay to the analogue output signal.	YES

4.9. Group 9 – G9: Comparators

4.9.1. Subgroup 9.1 – S9.1: Comparator 1

Parameter / Default Value	Name / Description	Range	Function	Set on RUN																																																																								
1 COMP 1 SEL=00	G9.1.1 / Source selection for Comparator 1	00 – 22	The source for comparator 1 can be set according to the following table:	NO																																																																								
			<table border="1"> <thead> <tr> <th>OPT.</th> <th>DESCRIPTION</th> <th>FUNCTION</th> </tr> </thead> <tbody> <tr> <td>00</td> <td>NONE</td> <td>There is no source for the comparator.</td> </tr> <tr> <td>01</td> <td>SPEED MOTOR</td> <td>Comparison signal is motor speed.</td> </tr> <tr> <td>02</td> <td>CURRENT MOTOR</td> <td>Motor current signal.</td> </tr> <tr> <td>03</td> <td>VOLTAGE MOTOR</td> <td>Motor voltage signal.</td> </tr> <tr> <td>04</td> <td>POWER MOTOR</td> <td>Motor power.</td> </tr> <tr> <td>05</td> <td>TORQUE MOTOR</td> <td>Motor torque signal.</td> </tr> <tr> <td>06</td> <td>PF MOTOR</td> <td>Motor cosine phi</td> </tr> <tr> <td>07</td> <td>TEMP MOTOR</td> <td>Motor temperature signal.</td> </tr> <tr> <td>08</td> <td>FREQUENCY IN</td> <td>Drive input frequency.</td> </tr> <tr> <td>09</td> <td>INPUT VOLTAGE</td> <td>Drive input voltage.</td> </tr> <tr> <td>10</td> <td>DC BUS</td> <td>DC Bus voltage.</td> </tr> <tr> <td>11</td> <td>DRIVE TEMP</td> <td>Drive temperature.</td> </tr> <tr> <td>12</td> <td>SPEED REF</td> <td>Speed reference.</td> </tr> <tr> <td>13</td> <td>Reserved</td> <td>Reserved for future use.</td> </tr> <tr> <td>14</td> <td>PID REFERENCE</td> <td>Speed reference in PID mode.</td> </tr> <tr> <td>15</td> <td>PID FEEDBACK</td> <td>System feedback signal.</td> </tr> <tr> <td>16</td> <td>PID ERROR</td> <td>PID error. Difference between reference and feedback signal of the sensor.</td> </tr> <tr> <td>17</td> <td>ANLG INPUT 1</td> <td>Signal connected to analogue input 1.</td> </tr> <tr> <td>18</td> <td>ANLG INPUT 2</td> <td>Signal connected to analogue input 2.</td> </tr> <tr> <td>19</td> <td>ANLG INPUT1+2</td> <td>The average of the analogue inputs 1 and 2.</td> </tr> <tr> <td>20</td> <td>CURRENT FLOW</td> <td>Analogue signal proportional to the read flow through analogue input or pulse input.</td> </tr> <tr> <td>21</td> <td>MAX SCALE</td> <td>We will get a maximum value, forcing the comparator in order to obtain the needed status.</td> </tr> <tr> <td>22</td> <td>ABSOLUT SPEED</td> <td>Comparison signal is motor speed without sign (absolute value).</td> </tr> </tbody> </table>		OPT.	DESCRIPTION	FUNCTION	00	NONE	There is no source for the comparator.	01	SPEED MOTOR	Comparison signal is motor speed.	02	CURRENT MOTOR	Motor current signal.	03	VOLTAGE MOTOR	Motor voltage signal.	04	POWER MOTOR	Motor power.	05	TORQUE MOTOR	Motor torque signal.	06	PF MOTOR	Motor cosine phi	07	TEMP MOTOR	Motor temperature signal.	08	FREQUENCY IN	Drive input frequency.	09	INPUT VOLTAGE	Drive input voltage.	10	DC BUS	DC Bus voltage.	11	DRIVE TEMP	Drive temperature.	12	SPEED REF	Speed reference.	13	Reserved	Reserved for future use.	14	PID REFERENCE	Speed reference in PID mode.	15	PID FEEDBACK	System feedback signal.	16	PID ERROR	PID error. Difference between reference and feedback signal of the sensor.	17	ANLG INPUT 1	Signal connected to analogue input 1.	18	ANLG INPUT 2	Signal connected to analogue input 2.	19	ANLG INPUT1+2	The average of the analogue inputs 1 and 2.	20	CURRENT FLOW	Analogue signal proportional to the read flow through analogue input or pulse input.	21	MAX SCALE	We will get a maximum value, forcing the comparator in order to obtain the needed status.	22	ABSOLUT SPEED	Comparison signal is motor speed without sign (absolute value).
			OPT.		DESCRIPTION	FUNCTION																																																																						
			00		NONE	There is no source for the comparator.																																																																						
			01		SPEED MOTOR	Comparison signal is motor speed.																																																																						
			02		CURRENT MOTOR	Motor current signal.																																																																						
			03		VOLTAGE MOTOR	Motor voltage signal.																																																																						
			04		POWER MOTOR	Motor power.																																																																						
			05		TORQUE MOTOR	Motor torque signal.																																																																						
			06		PF MOTOR	Motor cosine phi																																																																						
			07		TEMP MOTOR	Motor temperature signal.																																																																						
			08		FREQUENCY IN	Drive input frequency.																																																																						
			09		INPUT VOLTAGE	Drive input voltage.																																																																						
			10		DC BUS	DC Bus voltage.																																																																						
			11		DRIVE TEMP	Drive temperature.																																																																						
			12		SPEED REF	Speed reference.																																																																						
			13		Reserved	Reserved for future use.																																																																						
			14		PID REFERENCE	Speed reference in PID mode.																																																																						
			15		PID FEEDBACK	System feedback signal.																																																																						
			16		PID ERROR	PID error. Difference between reference and feedback signal of the sensor.																																																																						
			17		ANLG INPUT 1	Signal connected to analogue input 1.																																																																						
			18		ANLG INPUT 2	Signal connected to analogue input 2.																																																																						
19	ANLG INPUT1+2	The average of the analogue inputs 1 and 2.																																																																										
20	CURRENT FLOW	Analogue signal proportional to the read flow through analogue input or pulse input.																																																																										
21	MAX SCALE	We will get a maximum value, forcing the comparator in order to obtain the needed status.																																																																										
22	ABSOLUT SPEED	Comparison signal is motor speed without sign (absolute value).																																																																										
2 COMP 1 TYPE=0	G9.1.2 / Comparator 1 type selection	0 – 1	It allows selecting the operation mode of Comparator 1.	YES																																																																								
			<table border="1"> <thead> <tr> <th>OPT.</th> <th>DESCRIPTION</th> <th>FUNCTION</th> </tr> </thead> <tbody> <tr> <td>0</td> <td>Normal</td> <td>Comparator will be activated when the ON condition is given and will be deactivated when the OFF condition is given.</td> </tr> <tr> <td>1</td> <td>Window</td> <td>Comparator will be activated when signal is within the limits 1 and 2, and additionally when limit 2 is higher than limit 1. If limit 2 is lower than limit 1, comparator output logical function will be inverted.</td> </tr> </tbody> </table>		OPT.	DESCRIPTION	FUNCTION	0	Normal	Comparator will be activated when the ON condition is given and will be deactivated when the OFF condition is given.	1	Window	Comparator will be activated when signal is within the limits 1 and 2, and additionally when limit 2 is higher than limit 1. If limit 2 is lower than limit 1, comparator output logical function will be inverted.																																																															
OPT.	DESCRIPTION	FUNCTION																																																																										
0	Normal	Comparator will be activated when the ON condition is given and will be deactivated when the OFF condition is given.																																																																										
1	Window	Comparator will be activated when signal is within the limits 1 and 2, and additionally when limit 2 is higher than limit 1. If limit 2 is lower than limit 1, comparator output logical function will be inverted.																																																																										

Parameter / Default Value	Name / Description	Range	Function	Set on RUN																																										
3 SP C1 ON=+100[%] C1 ACTIVAT LEVEL	G9.1.3 / Activation value of Comparator 1 in Normal mode	-250% to +250%	It selects the activation value of Comparator 1 output. The comparator output will be activated if comparator source signal, selected in G9.1.1, is higher than the value set here, and ON delay time G9.1.6 has elapsed. Note: This parameter is only displayed in Normal mode of the comparator 'G9.1.2 COMP 1 TYPE=0'.	YES																																										
4 LIM 2 C1=+100[%] C1 WINDOW LIMIT2	G9.1.4 / Limit 2 for Comparator 1 in Window mode	-250% to +250%	It defines one of the limits to activate Comparator 1 in Window mode. The comparator output will be activated if comparator source signal, selected in G9.1.1, is within the two limits G9.1.4 and G9.1.5, and ON delay time G9.1.6 has elapsed. Note: This parameter is only displayed in Window mode of the comparator 'G9.1.2 COMP 1 TYPE=1'.	YES																																										
5 LIM 1 C1=+0[%] C1 WINDOW LIMIT1	G9.1.5 / Limit 1 for Comparator 1 in Window mode	-250% to +250%	It defines one of the limits to activate Comparator 1 in Window mode. The comparator output will be activated if comparator source signal, selected in G9.1.1, is within the two limits G9.1.4 and G9.1.5, and ON delay time G9.1.6 has elapsed. Note: This parameter is only displayed in Window mode of the comparator 'G9.1.2 COMP 1 TYPE=1'.	YES																																										
6 T C1 ON=0.0s C1 ACTIVAT DELAY	G9.1.6 / ON delay time for Comparator 1	0.0 – 999s	Delay time for the Comparator 1 output activation. When the activation condition is given in Normal or Window mode, the timer delays the activation of this signal for the time set in this parameter.	YES																																										
7 SP C1 OF=+0[%] C1 DEACTIV LEVEL	G9.1.7 / Deactivation value of Comparator 1 in Normal mode	-250% to +250%	This value selects the deactivation value of Comparator 1 output. The comparator output will be deactivated if comparator source signal, selected in G9.1.1, is lower than the value set here, and OFF delay time G9.1.8 has elapsed. Note: This parameter is only displayed in Normal mode of the comparator 'G9.1.2 COMP1 TYPE=0'.	YES																																										
8 T C1 OF=0.0s C1 DEACTIV DELAY	G9.1.8 / OFF delay time for Comparator 1	0.0 – 999s	Delay time for the Comparator 1 output deactivation. When the deactivation condition is given in Normal or Window mode, the timer delays the deactivation of this signal for the time set in this parameter.	YES																																										
9 SEL FUNT C1=00	G9.1.9 / Selection of output function for Comparator 1	00 – 15	<p>Several internal functions can be activated by Comparator 1 according to the system requirements. These functions are described in the following table:</p> <table border="1"> <thead> <tr> <th>OPT.</th> <th>DESCRIPTION</th> <th>FUNCTION</th> </tr> </thead> <tbody> <tr> <td>00</td> <td>NO USE</td> <td>Comparator output deactivated</td> </tr> <tr> <td>01</td> <td>START / STOP</td> <td>When it is activated, it gives the start command. When it is deactivated, it gives the stop command.</td> </tr> <tr> <td>02</td> <td>STOP 1</td> <td>It activates the stop mode 1.</td> </tr> <tr> <td>03</td> <td>STOP 2</td> <td>It activates the stop mode 2.</td> </tr> <tr> <td>04</td> <td>RESET</td> <td>Reset for the drive.</td> </tr> <tr> <td>05</td> <td>START + INCH1</td> <td>It activates Start + Inch speed 1.</td> </tr> <tr> <td>06</td> <td>START + INCH2</td> <td>It activates Start + Inch speed 2.</td> </tr> <tr> <td>07</td> <td>START + INCH3</td> <td>It activates Start + Inch speed 3.</td> </tr> <tr> <td>08</td> <td>INV SPEED</td> <td>It inverts the speed direction.</td> </tr> <tr> <td>09</td> <td>ACC / DEC 2</td> <td>It activates the alternative ramps.</td> </tr> <tr> <td>10</td> <td>REFERENCE 2</td> <td>It activates the alternative reference.</td> </tr> <tr> <td>11</td> <td>SPEED LIMIT 2</td> <td>It activates the alternative speed limits.</td> </tr> <tr> <td>15</td> <td>FLT COMPARATR</td> <td>Drive will trip by F73, F74 or F75 when comparator ON condition is satisfied.</td> </tr> </tbody> </table> <p>Note: If activation and deactivation levels are set to similar values and delay times are set to OFF, any noise that appears in the signals of selected source can cause an oscillation in the comparator activating incorrect operation. You should set these levels keeping a reasonable margin between them, and if it is necessary, set a delay time to improve the operation.</p>	OPT.	DESCRIPTION	FUNCTION	00	NO USE	Comparator output deactivated	01	START / STOP	When it is activated, it gives the start command. When it is deactivated, it gives the stop command.	02	STOP 1	It activates the stop mode 1.	03	STOP 2	It activates the stop mode 2.	04	RESET	Reset for the drive.	05	START + INCH1	It activates Start + Inch speed 1.	06	START + INCH2	It activates Start + Inch speed 2.	07	START + INCH3	It activates Start + Inch speed 3.	08	INV SPEED	It inverts the speed direction.	09	ACC / DEC 2	It activates the alternative ramps.	10	REFERENCE 2	It activates the alternative reference.	11	SPEED LIMIT 2	It activates the alternative speed limits.	15	FLT COMPARATR	Drive will trip by F73, F74 or F75 when comparator ON condition is satisfied.	NO
OPT.	DESCRIPTION	FUNCTION																																												
00	NO USE	Comparator output deactivated																																												
01	START / STOP	When it is activated, it gives the start command. When it is deactivated, it gives the stop command.																																												
02	STOP 1	It activates the stop mode 1.																																												
03	STOP 2	It activates the stop mode 2.																																												
04	RESET	Reset for the drive.																																												
05	START + INCH1	It activates Start + Inch speed 1.																																												
06	START + INCH2	It activates Start + Inch speed 2.																																												
07	START + INCH3	It activates Start + Inch speed 3.																																												
08	INV SPEED	It inverts the speed direction.																																												
09	ACC / DEC 2	It activates the alternative ramps.																																												
10	REFERENCE 2	It activates the alternative reference.																																												
11	SPEED LIMIT 2	It activates the alternative speed limits.																																												
15	FLT COMPARATR	Drive will trip by F73, F74 or F75 when comparator ON condition is satisfied.																																												

4.9.2. Subgroup 9.2 – S9.2: Comparator 2

Parameter / Default Value	Name / Description	Range	Function	Set on RUN									
1 COMP 2 SEL=00	G9.2.1 / Source selection for Comparator 2	00 – 22	Selection of Comparator 2 source. Selection options are the same as Comparator 1. See parameter G9.1.1.	NO									
2 COMP 2 TYPE=0	G9.2.2 / Comparator 2 type selection	0 – 1	<p>It allows selecting the operation mode of Comparator 2.</p> <table border="1"> <thead> <tr> <th>OPT.</th> <th>DESCRIPTION</th> <th>FUNCTION</th> </tr> </thead> <tbody> <tr> <td>0</td> <td>Normal</td> <td>Comparator will be activated when the ON condition is given and will be deactivated when the OFF condition is given.</td> </tr> <tr> <td>1</td> <td>Window</td> <td>Comparator will be activated when signal is within the limits 1 and 2, and additionally when limit 2 is higher than limit 1. If limit 2 is lower than limit 1, comparator output logical function will be inverted.</td> </tr> </tbody> </table>	OPT.	DESCRIPTION	FUNCTION	0	Normal	Comparator will be activated when the ON condition is given and will be deactivated when the OFF condition is given.	1	Window	Comparator will be activated when signal is within the limits 1 and 2, and additionally when limit 2 is higher than limit 1. If limit 2 is lower than limit 1, comparator output logical function will be inverted.	YES
OPT.	DESCRIPTION	FUNCTION											
0	Normal	Comparator will be activated when the ON condition is given and will be deactivated when the OFF condition is given.											
1	Window	Comparator will be activated when signal is within the limits 1 and 2, and additionally when limit 2 is higher than limit 1. If limit 2 is lower than limit 1, comparator output logical function will be inverted.											
3 SP C2 ON=+100[%] C2 ACTIVAT LEVEL	G9.2.3 / Activation value of Comparator 2 in Normal mode	-250% to +250%	<p>It selects the activation value of Comparator 2 output. The comparator output will be activated if comparator source signal, selected in G9.2.1, is higher than the value set here, and On delay time G9.2.6 has elapsed.</p> <p>Note: This parameter is only displayed in Normal mode of the comparator 'G9.2.2 COMP 2 TYPE=0'.</p>	YES									
4 LIM 2 C2=+100[%] C2 WINDOW LIMIT2	G9.2.4 / Limit 2 for Comparator 2 in Window mode	-250% to +250%	<p>It defines one of the limits to activate Comparator 2 in Window mode. The comparator output will be activated if comparator source signal, selected in G9.2.1, is within the two limits G9.2.4 and G9.2.5, and ON delay time G9.1.6 has elapsed.</p> <p>Note: This parameter is only displayed in Window mode of the comparator 'G9.2.2 COMP 2 TYPE=1'.</p>	YES									
5 LIM 1 C2=+0[%] C2 WINDOW LIMIT1	G9.2.5 / Limit 1 for Comparator 2 in Window mode	-250% to +250%	<p>It defines one of the limits to activate Comparator 2 in Window mode. The comparator output will be activated if comparator source signal, selected in G9.2.1, is within the two limits G9.2.4 and G9.2.5, and ON delay time G9.2.6 has elapsed.</p> <p>Note: This parameter is only displayed in Window mode of the comparator 'G9.2.2 COMP 2 TYPE=1'.</p>	YES									
6 T C2 ON=0.0s C2 ACTIVAT DELAY	G9.2.6 / ON delay time for Comparator 2	0.0 – 999s	<p>Delay time for the Comparator 2 output activation. When the activation condition is given in Normal or Window mode, the timer delays the activation of this signal for the time set in this parameter.</p>	YES									
7 SP C2 OF=+0[%] C2 DEACTIV LEVEL	G9.2.7 / Deactivation value of Comparator 2 in Normal mode	-250% to +250%	<p>This value selects the deactivation point of Comparator 2 output. The comparator output will be deactivated if comparator source signal, selected in G9.2.1, is lower than the value set here, and OFF delay time G9.2.8 has elapsed.</p> <p>Note: This parameter is only displayed in Normal mode of the comparator 'G9.2.2 COMP 2 TYPE=0'.</p>	YES									
8 T C2 OF=0.0s C2 DEACTIV DELAY	G9.2.8 / OFF delay time for Comparator 2	0.0 – 999s	<p>Delay time for the Comparator 2 output deactivation. When the deactivation condition is given in Normal or Window mode, the timer delays the deactivation of this signal for the time set in this parameter.</p>	YES									
9 SEL FUNT C2=00	G9.2.9 / Selection of output function for Comparator 2	00 – 15	<p>Several internal functions can be activated for Comparator 2 according to the systems requirements. These functions are described in the table of parameter G9.1.9.</p>	NO									

4.9.3. Subgroup 9.3 – S9.3: Comparator 3

Parameter / Default Value	Name / Description	Range	Function	Set on RUN									
1 COMP 3 SEL=00	G9.3.1 / Source selection for Comparator 3	00 – 22	Selection of Comparator 3 source. Selection options are the same as Comparator 1. See parameter G9.1.1.	NO									
2 COMP 3 TYPE=0	G9.3.2 / Comparator 3 type selection	0 – 1	<p>It allows selecting the operation mode of Comparator 3.</p> <table border="1"> <thead> <tr> <th>OPT.</th> <th>DESCRIPTION</th> <th>FUNCTION</th> </tr> </thead> <tbody> <tr> <td>0</td> <td>Normal</td> <td>Comparator will be activated when the ON condition is given and will be deactivated when the OFF condition is given.</td> </tr> <tr> <td>1</td> <td>Window</td> <td>Comparator will be activated when signal is within limits 1 and 2, and additionally when limit 2 is higher than limit 1. If limit 2 is lower than limit 1, comparator output logical function will be inverted.</td> </tr> </tbody> </table>	OPT.	DESCRIPTION	FUNCTION	0	Normal	Comparator will be activated when the ON condition is given and will be deactivated when the OFF condition is given.	1	Window	Comparator will be activated when signal is within limits 1 and 2, and additionally when limit 2 is higher than limit 1. If limit 2 is lower than limit 1, comparator output logical function will be inverted.	YES
OPT.	DESCRIPTION	FUNCTION											
0	Normal	Comparator will be activated when the ON condition is given and will be deactivated when the OFF condition is given.											
1	Window	Comparator will be activated when signal is within limits 1 and 2, and additionally when limit 2 is higher than limit 1. If limit 2 is lower than limit 1, comparator output logical function will be inverted.											
3 SP C3 ON=+100[%] C3 ACTIVAT LEVEL	G9.3.3 / Activation value of Comparator 3 in Normal mode	-250% to +250%	It selects the activation value of Comparator 3 output. The comparator output will be activated if comparator source signal, selected in G9.3.1, is higher than the value set here, and ON delay time G9.3.6 has elapsed. Note: This parameter is only displayed in Normal mode of the comparator 'G9.3.2 COMP 3 TYPE=0'.	YES									
4 LIM 2 C3=+100[%] C3 WINDOW LIMIT2	G9.3.4 / Limit 2 for Comparator 3 in Window mode	-250% to +250%	It defines one of the limits to activate Comparator 3 in Window mode. The comparator output will be activated if comparator source signal, selected in G9.3.1, is within the two limits G9.3.4 and G9.3.5, and ON delay time G9.3.6 has elapsed. Note: This parameter is only displayed in Window mode of the comparator 'G9.3.2 COMP 3 TYPE=1'.	YES									
5 LIM 1 C3=+0[%] C3 WINDOW LIMIT1	G9.3.5 / Limit 1 for Comparator 3 in Window mode	-250% to +250%	It defines one of the limits to activate Comparator 3 in Window mode. The comparator output will be activated if comparator source signal, selected in G9.3.1, is within the two limits G9.3.4 and G9.3.5, and ON delay time G9.3.6 has elapsed. Note: This parameter is only displayed in Window mode of the comparator 'G9.3.2 COMP 3 TYPE=0'.	YES									
6 T C3 ON=0.0s C3 ACTIVAT DELAY	G9.3.6 / ON delay time for Comparator 3	0.0 – 999s	Delay time for the Comparator 3 output activation. When the activation condition is given in Normal or Window mode, the timer delays the activation of this signal for the time set in this parameter.	YES									
7 SP C3 OF=+0[%] C3 DEACTIV LEVEL	G9.3.7 / Deactivation value of Comparator 3 in Normal mode	-250% to +250%	This value selects the deactivation value of Comparator 3 output. The comparator output will be deactivated if comparator source signal, selected in G9.3.1, is lower than the value set here, and OFF delay time G9.3.8 has elapsed. Note: This parameter is only displayed in Normal mode of the comparator 'G9.3.2 COMP 3 TYPE=0'.	YES									
8 T C3 OF=0.0s C3 DEACTIV DELAY	G9.3.8 / OFF delay time for Comparator 3	0.0 – 999s	Delay time for the Comparator 3 output deactivation. When the deactivation condition is given in Normal or Window mode, the timer delays the deactivation of this signal for the time set in this parameter.	YES									
9 SEL FUNT C3=00	G9.3.9 / Selection of output function for Comparator 3	00 – 15	Several internal functions can be activated for Comparator 3 according to the system requirements. These functions are described in the table of parameter G9.1.9.	NO									

4.10. Group 10 – G10: Limits

Parameter / Default Value	Name / Description	Range	Function	Set on RUN						
1 MIN1 SP= 0% SPEED MIN LIMIT1	G10.1 / Minimum speed limit 1	-250% to Max speed 1	This sets the minimum speed limit 1 that can be applied to the motor by the drive. It is set in percentage of motor rated speed.	YES						
2 MAX1 SP=+100% SPEED MAX LIMIT1	G10.2 / Maximum speed limit 1	Min. speed 1 to +250%	This sets the maximum speed limit 1 that can be applied to the motor by the drive. If the reference is higher than the value set in this parameter, the drive will ignore that reference and will operate the motor at the value set in this screen. It is set in percentage of motor rated speed.	YES						
3 MIN2 SP=-100% SPEED MIN LIMIT2	G10.3 / Minimum speed limit 2	-250% to Max speed 2	This sets the minimum speed limit 2 that can be applied to the motor by the drive. It is set in percentage of motor rated speed. Note: Selection of minimum speed limit 2 is done via a digital input or comparator output function.	YES						
4 MAX2 SP=+100% SPEED MAX LIMIT2	G10.4 / Maximum speed limit 2	Min. speed 2 to +250%	This sets the maximum speed limit 2 that can be applied to the motor by the drive. If the reference is higher than the value set in this parameter, the drive will ignore that reference and will operate the motor at the value set in this screen. It is set in percentage of motor rated speed.	YES						
5 I LIMIT= ___ A (*) MAX CURRENT	G10.5 / Current limit	0.25 to 1.50In, OFF	Output current limit. Motor current will be within this programmed limit. When this protection is active the SD700 status of current limitation (ILT) is displayed. Note: We do not recommend that current limit works constantly in applications when the motor is at steady speed status. Damage may occur to the motor and torque variations can affect the load. Current limit should work only when an overload occurs, or due to excessive acceleration and deceleration values, or because motor data details are entered incorrectly.	YES						
6 I LIM TO= OFF TIMEOUT MAX CURRE	G10.6 / Trip time because of current limit	0 to 60s, OFF	If the drive is operated continually at current limit for the time set in this screen the drive generates a fault.	YES						
7 I. MAX2= ___ A (*) MAX CURRENT 2	G10.7 / Alternative current limit	0.25 to 1.50In, OFF	This limit operates with the same philosophy than G10.5, but for the second current limit.	YES						
8 MI2 brSP=OFF MAX CURR BRK SPD	G10.8 / Change speed for I max 2	OFF=0%, +1 to +250%	It allows setting the speed level to change from current limit 1 to current limit 2. Additionally it is possible to select the alternative current limit 2 using a digital input configured as option 23.	YES						
9 MAX TOR=+150% MAX TORQUE	G10.9 / Torque limit	0% to +250%	This value is the maximum motor torque the drive will allow the motor to supply to the load. It is set in percentage of motor rated torque.	YES						
10 T LIM TO=OFF TIMEOUT MAX TORQ	G10.10 / Trip time because of torque limit	0 to 60s, OFF	If the drive is operated continually at torque limit for the time set in this screen the drive generates a fault.	YES						
11 INVERSION ?=N	G10.11 / To enable speed inversion	N Y	The drive can be configured to prevent the motor running in negative direction. <table border="1" style="margin-left: 20px;"> <thead> <tr> <th>OPT.</th> <th>FUNCTION</th> </tr> </thead> <tbody> <tr> <td>N=NO</td> <td>Motor running in negative rotation direction is not allowed.</td> </tr> <tr> <td>Y=YES</td> <td>Motor running in both rotation directions is allowed.</td> </tr> </tbody> </table>	OPT.	FUNCTION	N=NO	Motor running in negative rotation direction is not allowed.	Y=YES	Motor running in both rotation directions is allowed.	YES
OPT.	FUNCTION									
N=NO	Motor running in negative rotation direction is not allowed.									
Y=YES	Motor running in both rotation directions is allowed.									
12 I LIM RGN=OFF CURR.LIMIT.RGN	G10.12 / Regenerating current limit	OFF = 40%·In (motor), 40.1% to 200%·In (drive)	Output current limit during regeneration. It keeps the motor load current within the adjusted limit during regeneration. When this protection is active, the display shows that the SD700 is limiting current (ILT). If this parameter is set to 'OFF', the algorithm is not enabled.	YES						
13 Ilim_rgnTO=OFF ILim.Regen.Tmout	G10.13 / Regenerating current limit trip time	0 to 60s, OFF	It allows setting the trip time once the current limit is reached.	YES						
14 T/I LIM SP = N	G10.14 / Torque limit algorithm	N Y	It allows disabling of the torque/current limit algorithm. <table border="1" style="margin-left: 20px;"> <thead> <tr> <th>OPT.</th> <th>FUNCTION</th> </tr> </thead> <tbody> <tr> <td>N=NO</td> <td>Algorithm is enable. By limiting the current or the torque, the equipment reduces its speed.</td> </tr> <tr> <td>Y=YES</td> <td>Algorithm is disable but the equipment still using current or torque limit (G10.5 and G10.9) and timeouts (G10.6 and G10.10) which could mean drive trip.</td> </tr> </tbody> </table>	OPT.	FUNCTION	N=NO	Algorithm is enable. By limiting the current or the torque, the equipment reduces its speed.	Y=YES	Algorithm is disable but the equipment still using current or torque limit (G10.5 and G10.9) and timeouts (G10.6 and G10.10) which could mean drive trip.	YES
OPT.	FUNCTION									
N=NO	Algorithm is enable. By limiting the current or the torque, the equipment reduces its speed.									
Y=YES	Algorithm is disable but the equipment still using current or torque limit (G10.5 and G10.9) and timeouts (G10.6 and G10.10) which could mean drive trip.									
15 Rg TQ L = 150%	G10.15 / Torque limit range	0 to 250%	It allows limiting the regenerative torque of the motor.	YES						

* This value depends on the drive rating.

4.11. Group 11 – G11: Protections

Parameter / Default Value	Name / Description	Range	Function	Set on RUN															
1 SP LIM TO=OFF TMAX LIMITIN SPD	G11.1 / Trip time because of speed limit	0.1 to 60s, OFF	If the drive is operated continually at the speed limit for the time set in this screen the drive generates a fault 'F49 SPD LIMIT'.	YES															
2 STOP TO=OFF TIMEOUT STOPPING	G11.2 / Maximum time for stop limit	OFF=0.0 to 999s	It supplies a safety function to stop the drive automatically if the motor has not stopped after the time set in this parameter has elapsed and if the drive has received a stop command. The drive will fault on 'F45 STOP T/O'. This function is used to protect from uncontrolled stops where motor needs a longer time than the predict time to stop. As well as other protections integrated into the drive, this time can be set to turn off the output voltage and stop the motor by free run if this time has elapsed and the motor has not stopped completely. Controlled stop time is calculated in standard conditions during system operation. Stop limit time should be set to a higher value than controlled stop time value.	YES															
3 GND I LIMIT=10% GND CURR MAX LEV	G11.3 / Ground fault detection	OFF, 0 – 30% In	It allows drive to turn off its output to the motor generating a fault 'F20 GROUND FLT' automatically if the leakage current value is above the value set in this parameter.	YES															
4 LOW VOLT=360V LO INPUT VOLTAGE	G11.4 / Low input voltage level	323 – 425V 586 – 621V	Input low voltage protection is a combination of parameters G11.4 and G11.5. Drive turns off its output generating a fault 'F14 LW V IN' when average voltage, measured in the drive input, is below the value set in G11.4 for the time set in G11.5.	YES															
5 LOW V TO=5s LO INP VOL TIMEO	G11.5 / Trip time because of low input voltage	0.0 – 60s, OFF	In case of the drive has a power supply of 690V, the default value in G11.4 will be 600V and the range will be 586 – 621V.	YES															
6 HIGH VOLT=500V HI INPUT VOLTAGE	G11.6 / High input voltage level	418 – 587V 726 – 759V	Input high voltage protection is a combination of parameters G11.6 and G11.7. Drive turns off its output generating a fault 'F13 HI V IN' when average voltage, measured in the drive input, is above the value set in G11.6 for the time set in G11.7.	YES															
7 HI V TO=5s HI INP VOL TIMEO	G11.7 / Trip time because of high input voltage	0.0 – 60s, OFF	In case of the drive has a power supply of 690V, the default value in G11.6 will be 750V and the range will be 726 – 759V.	YES															
8 Dlasy VO = 5s VOUT asyTRIP DLY	G11.8 / Trip delay time due to output voltage imbalance	0.0s – 10s, OFF	It allows setting a delay time before tripping once output voltage imbalance has been detected. Once this time is elapsed, the drive trips due to 'F18 IMB V OUT'.	YES															
9 LOW V BHV=1	G11.9 / Performance in case of input power loss	0 – 3	Modifies the drive response following an input power loss while motor is running according to next adjusts: <table border="1" data-bbox="730 1294 1262 1691"> <thead> <tr> <th>OPT.</th> <th>DESCRIPTION</th> <th>FUNCTION</th> </tr> </thead> <tbody> <tr> <td>0</td> <td>NO FAULT</td> <td>No action will be done by the drive.</td> </tr> <tr> <td>1</td> <td>FAULTS</td> <td>Drive will trip because of fault 'F11 VIN LOSS'.</td> </tr> <tr> <td>2</td> <td>STOP</td> <td>Drive will not trip because of fault and it will try to control the motor to a stop while DC Bus voltage level allows it.</td> </tr> <tr> <td>3</td> <td>DipVoltRecover</td> <td>After a momentary power loss has occurred, an algorithm of controlled recovery is activated. Due to this, the motor speed is not affected significantly. In case of loads with high inertia, the reduction of the speed will be minimal.</td> </tr> </tbody> </table>	OPT.	DESCRIPTION	FUNCTION	0	NO FAULT	No action will be done by the drive.	1	FAULTS	Drive will trip because of fault 'F11 VIN LOSS'.	2	STOP	Drive will not trip because of fault and it will try to control the motor to a stop while DC Bus voltage level allows it.	3	DipVoltRecover	After a momentary power loss has occurred, an algorithm of controlled recovery is activated. Due to this, the motor speed is not affected significantly. In case of loads with high inertia, the reduction of the speed will be minimal.	YES
OPT.	DESCRIPTION	FUNCTION																	
0	NO FAULT	No action will be done by the drive.																	
1	FAULTS	Drive will trip because of fault 'F11 VIN LOSS'.																	
2	STOP	Drive will not trip because of fault and it will try to control the motor to a stop while DC Bus voltage level allows it.																	
3	DipVoltRecover	After a momentary power loss has occurred, an algorithm of controlled recovery is activated. Due to this, the motor speed is not affected significantly. In case of loads with high inertia, the reduction of the speed will be minimal.																	

Parameter / Default Value	Name / Description	Range	Function	Set on RUN						
10 PTC EXT ?=N	G11.10 / PTC motor option	N Y	A PTC sensor can be connected directly to the drive to detect high motor temperature (terminals 8 and 9 on control board). If PTC value is higher or equal than $1K5 \pm 10\%$, a fault will be generated in the drive 'F40 EXT / PTC'. On the other hand, if the value decreases below $90\Omega \pm 10\%$, a fault will be generated too. <table border="1"> <thead> <tr> <th>OPT.</th> <th>FUNCTION</th> </tr> </thead> <tbody> <tr> <td>N=NO</td> <td>PTC motor option is disabled.</td> </tr> <tr> <td>Y=YES</td> <td>PTC motor option is enabled.</td> </tr> </tbody> </table>	OPT.	FUNCTION	N=NO	PTC motor option is disabled.	Y=YES	PTC motor option is enabled.	YES
OPT.	FUNCTION									
N=NO	PTC motor option is disabled.									
Y=YES	PTC motor option is enabled.									
11 PUMP OV=20.0A PUMP OVERLOAD LV	G11.11 / Pump overload level	0.0 – 3000A	Overload protection is a combination of parameters G11.11, G11.12 and G11.13. Drive turns off its output generating a fault 'F57 PUMP OVERLOA' when the output current of the drive is higher than the current set in G11.11 for the time adjusted in parameter G11.13. By means of parameter G11.12, we can adjust the value of low-pass filter for the current reading to avoid oscillations.	YES						
12 PMOvl FIL=OFF PMP OVL FILTER	G11.12 / Filter for pump overload	OFF=0, 0.1 to 20.0s		YES						
13 Povl DLY=OFF PMP OVERLOAD DLY	G11.13 / Trip delay time because of pump overload	OFF=0, 1 to 999.9s		YES						
14 UNDERLOAD=N	G11.14 / To enable underload protection	N Y	It allows the possibility of protecting the pump from underload status. <table border="1"> <thead> <tr> <th>OPT.</th> <th>FUNCTION</th> </tr> </thead> <tbody> <tr> <td>N=NO</td> <td>Underload protection disabled.</td> </tr> <tr> <td>Y=YES</td> <td>Underload protection enabled.</td> </tr> </tbody> </table> <p>To protect the pump from underload status is necessary to follow the next steps: Set this parameter to 'YES'. Set an underload current value (in G11.15) below which the first detection condition will be met. Set an underload speed value (in G11.16) above which the second detection condition will be met. Set a delay time to activate underload protection (in G11.17), once elapsed, last underload condition will be activated. If three previous conditions are given, the drive will stop the pump to protect it from underload status.</p>	OPT.	FUNCTION	N=NO	Underload protection disabled.	Y=YES	Underload protection enabled.	YES
OPT.	FUNCTION									
N=NO	Underload protection disabled.									
Y=YES	Underload protection enabled.									
15 ULD CUR= ___ A (*) UNDERLOAD CURREN	G11.15 / Underload current	(0.2 to 1.50)·In	Setting of the underload current below which the first detection condition to activate the protection is met. This parameter operates together with parameters G11.16 and G11.17.	YES						
16 ULD SPD=+100% UNDERLOAD SPEED	G11.16 / Underload speed	+0.1% to +250%	Setting of the underload speed above which the second detection condition to activate the protection is met. This parameter operates together with parameters G11.15 and G11.17.	YES						
17 ULD DELY=10s UNDERLOAD DELAY	G11.17 / Delay time to activate underload protection	0 – 999s	Setting of the delay time to activate the underload protection. The drive will wait for this time before activating the protection and then will stop. This parameter operates together with parameters G11.15 and G11.16.	YES						
18 DEC.SPdly=OFF DECREM.SP.DELAY	G11.18 / Speed decreasing delay time	OFF, 1 to 10s	It allows setting the delay time before beginning the starting when the motor is still rotating and just before the drive trips by F2 or F16 (high Vbus). If this parameter is set to 'OFF', the drive will trip by F2 or F16.	YES						
19 Sp.SRCH.I =10% SPD.SEARCH INCR.	G.11.19 / Increasing of speed searching	2 to 40%·In	It allows setting the speed increasing to begin the speed searching in order to starting with the motor still rotating when the drive is ready.	YES						
21 MSpeedT= OFF	G11.21 / Minimum Speed Timeout	OFF, 0.1 to 60.0	Establishes the period of time that the drive has to maintain the minimum speed before triggering F23.	YES						
22 Dasy IO = 5.0s	G11.22 / IOOUT asyTRIP DLY	0.0 to 10.0 OFF	Allows the setting of a delay time before the trip when an output current unbalance is detected. After this time, the drive will trip by 'F19 IMB I OUT'	YES						

* This value depends on the drive rating.

4.12. Group 12 – G12: Auto Reset

Parameter / Default Value	Name / Description	Range	Function	Set on RUN						
1 AUTO RESET=N	G12.1 / Auto Reset	N Y	<p>This function resets the drive automatically after a fault.</p> <table border="1"> <thead> <tr> <th>OPT.</th> <th>FUNCTION</th> </tr> </thead> <tbody> <tr> <td>N=NO</td> <td>Auto Reset is disabled.</td> </tr> <tr> <td>Y=YES</td> <td>Auto Reset is enabled.</td> </tr> </tbody> </table> <p>When this function is active, faults programmed in G12.5 to G12.8 will be reset.</p> <p> Caution: Auto Reset function can cause unexpected automatic starts. Ensure the installation is configured for Auto Reset to prevent damage to property or personnel.</p>	OPT.	FUNCTION	N=NO	Auto Reset is disabled.	Y=YES	Auto Reset is enabled.	YES
OPT.	FUNCTION									
N=NO	Auto Reset is disabled.									
Y=YES	Auto Reset is enabled.									
2 ATTEMP NUMBR=1 MAX ATTEMPT NUMB	G12.2 / Number of Auto Reset attempts	1 – 5	Allows setting of the maximum number of Auto Reset attempts. Drive will try to reset as many times as the number of attempts set in this screen after a fault occurs. This parameter and 'G12.4 RS COUNT' control the drive to carry out Auto Reset function in a controlled manner.	YES						
3 R STR DEL=5s TIME BEFORE RESET	G12.3 / Delay time before Auto Reset	5 – 120s	Allows setting of the time elapsed from the fault occurring before attempting auto reset.	YES						
4 RS COUNT=15min AUTORESET TIMOUT	G12.4 / Reset time for the counter of Auto Reset attempts	1 – 60min	<p>Allows setting of the time that once elapsed will reset the Auto Reset attempt counter to zero.</p> <p>Two situations are possible:</p> <p>a) If the SD700 is successfully restarted and runs for a period exceeding the value set in this screen then the attempt counter G12.2 will be reset to zero.</p> <p>b) If the total number of reset attempts is exceeded within this time period the SD700 will fault on the last fault condition. The SD700 will remain in a fault condition until the unit is manually reset.</p>	YES						

Parameter / Default Value	Name / Description	Range	Function	Set on RUN																																																																														
5 F1 AUTO RST=0	G12.5 / Selection of fault 1 to be reset	0 – 27	<p>If Auto Reset selection is enabled, the SD700 will automatically resets the faults selected according to the following table:</p> <table border="1"> <thead> <tr> <th>OPT.</th> <th>DESCRIPTION</th> <th>FUNCTION</th> </tr> </thead> <tbody> <tr> <td>0</td> <td>0 NO AUTO RESET</td> <td>If G12.5 to G12.8 is set with this value, Auto Reset will not be undertaken.</td> </tr> <tr> <td>1</td> <td>ALL THE FLTS</td> <td>All faults will be reset automatically.</td> </tr> <tr> <td>2</td> <td>11 VIN LOSS</td> <td>To reset fault F11, input power loss.</td> </tr> <tr> <td>3</td> <td>13 HIGH V IN</td> <td>To reset fault F13, high input voltage.</td> </tr> <tr> <td>4</td> <td>14 LOW V IN</td> <td>To reset fault F14, low input voltage.</td> </tr> <tr> <td>5</td> <td>18 DSQ V OUT</td> <td>To reset fault F18, output voltage imbalance.</td> </tr> <tr> <td>6</td> <td>19 DSQ I OUT</td> <td>To reset fault F19, output current imbalance.</td> </tr> <tr> <td>7</td> <td>20 IGND FAULT</td> <td>To reset fault F20, ground fault.</td> </tr> <tr> <td>8</td> <td>21 ILT TIMEOUT</td> <td>To reset fault F21, current limit time out.</td> </tr> <tr> <td>9</td> <td>22 TLT TIMEOUT</td> <td>To reset fault F22, torque limit time out.</td> </tr> <tr> <td>10</td> <td>27 SOFTCHRG</td> <td>To reset fault F27, DC Bus charge fault.</td> </tr> <tr> <td>11</td> <td>40 FLT</td> <td>To reset fault F40, motor PTC fault.</td> </tr> <tr> <td>12</td> <td>41 COMMS TRIP</td> <td>To reset fault F41, fault signal from communication net.</td> </tr> <tr> <td>13</td> <td>42 AIN1 MISSING</td> <td>To reset fault F42, Analogue Input 1 loss.</td> </tr> <tr> <td>14</td> <td>43 AIN2 MISSING</td> <td>To reset fault F43, Analogue Input 2 loss.</td> </tr> <tr> <td>15</td> <td>47 COMMS ERROR</td> <td>To reset fault F47, communication time out.</td> </tr> <tr> <td>16</td> <td>49 SPEED LIMIT ER</td> <td>To reset fault F49, exceeded speed limit.</td> </tr> <tr> <td>17</td> <td>65 LOW PRESSURE</td> <td>To reset fault F65, low pressure.</td> </tr> <tr> <td>18</td> <td>66 HI PRESSURE</td> <td>To reset fault F66, maximum pressure.</td> </tr> <tr> <td>19</td> <td>67 LOW WATER</td> <td>Fault F67 is reset, low water.</td> </tr> <tr> <td>20</td> <td>31 SCR L1 FAULT</td> <td>To reset fault F31, fault on phase L1 of rectifier.</td> </tr> <tr> <td>21</td> <td>32 SCR L2 FAULT</td> <td>To reset fault F32, fault on phase L2 of rectifier.</td> </tr> <tr> <td>22</td> <td>33 SCR L3 FAULT</td> <td>To reset fault F33, fault on phase L3 of rectifier.</td> </tr> <tr> <td>23</td> <td>68 CAVIT/UNDERL</td> <td>To reset fault F68, cavitation / underload trip.</td> </tr> <tr> <td>27</td> <td>56 EXTER FAULT</td> <td>Resets F50 fault, Emergency Stop.</td> </tr> </tbody> </table>	OPT.	DESCRIPTION	FUNCTION	0	0 NO AUTO RESET	If G12.5 to G12.8 is set with this value, Auto Reset will not be undertaken.	1	ALL THE FLTS	All faults will be reset automatically.	2	11 VIN LOSS	To reset fault F11, input power loss.	3	13 HIGH V IN	To reset fault F13, high input voltage.	4	14 LOW V IN	To reset fault F14, low input voltage.	5	18 DSQ V OUT	To reset fault F18, output voltage imbalance.	6	19 DSQ I OUT	To reset fault F19, output current imbalance.	7	20 IGND FAULT	To reset fault F20, ground fault.	8	21 ILT TIMEOUT	To reset fault F21, current limit time out.	9	22 TLT TIMEOUT	To reset fault F22, torque limit time out.	10	27 SOFTCHRG	To reset fault F27, DC Bus charge fault.	11	40 FLT	To reset fault F40, motor PTC fault.	12	41 COMMS TRIP	To reset fault F41, fault signal from communication net.	13	42 AIN1 MISSING	To reset fault F42, Analogue Input 1 loss.	14	43 AIN2 MISSING	To reset fault F43, Analogue Input 2 loss.	15	47 COMMS ERROR	To reset fault F47, communication time out.	16	49 SPEED LIMIT ER	To reset fault F49, exceeded speed limit.	17	65 LOW PRESSURE	To reset fault F65, low pressure.	18	66 HI PRESSURE	To reset fault F66, maximum pressure.	19	67 LOW WATER	Fault F67 is reset, low water.	20	31 SCR L1 FAULT	To reset fault F31, fault on phase L1 of rectifier.	21	32 SCR L2 FAULT	To reset fault F32, fault on phase L2 of rectifier.	22	33 SCR L3 FAULT	To reset fault F33, fault on phase L3 of rectifier.	23	68 CAVIT/UNDERL	To reset fault F68, cavitation / underload trip.	27	56 EXTER FAULT	Resets F50 fault, Emergency Stop.	YES
				OPT.	DESCRIPTION	FUNCTION																																																																												
				0	0 NO AUTO RESET	If G12.5 to G12.8 is set with this value, Auto Reset will not be undertaken.																																																																												
				1	ALL THE FLTS	All faults will be reset automatically.																																																																												
				2	11 VIN LOSS	To reset fault F11, input power loss.																																																																												
				3	13 HIGH V IN	To reset fault F13, high input voltage.																																																																												
4	14 LOW V IN	To reset fault F14, low input voltage.																																																																																
5	18 DSQ V OUT	To reset fault F18, output voltage imbalance.																																																																																
6	19 DSQ I OUT	To reset fault F19, output current imbalance.																																																																																
7	20 IGND FAULT	To reset fault F20, ground fault.																																																																																
8	21 ILT TIMEOUT	To reset fault F21, current limit time out.																																																																																
9	22 TLT TIMEOUT	To reset fault F22, torque limit time out.																																																																																
10	27 SOFTCHRG	To reset fault F27, DC Bus charge fault.																																																																																
11	40 FLT	To reset fault F40, motor PTC fault.																																																																																
12	41 COMMS TRIP	To reset fault F41, fault signal from communication net.																																																																																
13	42 AIN1 MISSING	To reset fault F42, Analogue Input 1 loss.																																																																																
14	43 AIN2 MISSING	To reset fault F43, Analogue Input 2 loss.																																																																																
15	47 COMMS ERROR	To reset fault F47, communication time out.																																																																																
16	49 SPEED LIMIT ER	To reset fault F49, exceeded speed limit.																																																																																
17	65 LOW PRESSURE	To reset fault F65, low pressure.																																																																																
18	66 HI PRESSURE	To reset fault F66, maximum pressure.																																																																																
19	67 LOW WATER	Fault F67 is reset, low water.																																																																																
20	31 SCR L1 FAULT	To reset fault F31, fault on phase L1 of rectifier.																																																																																
21	32 SCR L2 FAULT	To reset fault F32, fault on phase L2 of rectifier.																																																																																
22	33 SCR L3 FAULT	To reset fault F33, fault on phase L3 of rectifier.																																																																																
23	68 CAVIT/UNDERL	To reset fault F68, cavitation / underload trip.																																																																																
27	56 EXTER FAULT	Resets F50 fault, Emergency Stop.																																																																																
6 F2 AUTO RST=0	G12.6 / Selection of fault 2 to be reset	0 – 27		YES																																																																														
				7 F3 AUTO RST=0	G12.7 / Selection of fault 3 to be reset	0 – 27		YES																																																																										
								8 F4 AUTO RST=0	G12.8 / Selection of fault 4 to be reset	0 – 27		YES																																																																						

 **Caution:** When the fault selection for auto reset is undertaken the user should pay special attention to option 1 'All the faults'. In this case, the protections of the drive and motor will be disabled. It is not recommended to select this option since the drive could try to reset internal trips causing serious damage to the drive.

4.13. Group 13 – G13: Fault History

Parameter / Default Value	Name / Description	Range	Function	Set on RUN																																																																																																																																								
1 F0 NO FAULT LAST FLT=FXX	G13.1 / Register 1 of fault history	-	<p>The first parameter of this group allows visualizing the information about the last fault and additionally, it will be used as the first register of fault history.</p> <p>Drive shows this screen in the case of a trip. Pressing * key approx two seconds provides access to the extended information that shows the order of fault: LAST FAULT=Fxx (when fault is reset). The equipment is reset by pressing the STOP-RESET key from display or by using an external reset (if connected). Several faults can be reset automatically using Auto Reset (See group G12).</p> <p>A list of the last six faults in chronological order is shown. The most recent fault appears in first place (G13.1). Each time that a fault occurs, the drive shows the fault in parameter G13.1. After the fault is solved and reset, this fault will be shifted to the following position of fault register (G13.2). The previous faults will shift down one position. The oldest fault message (G13.6) will be lost.</p> <p>Pressing * key approx two seconds provides access to the extended information that shows the order of fault: FIFTH FAULT=Fxx up to FIRST FAULT=Fxx</p> <p>The following table shows all the faults:</p> <table border="1"> <thead> <tr> <th>COD</th> <th>FAULT</th> <th>COD</th> <th>FAULT</th> </tr> </thead> <tbody> <tr><td>0</td><td>F0 NO FAULT</td><td>35</td><td>F35 PHS L1 LOS</td></tr> <tr><td>1</td><td>F1 I LIM FLT</td><td>36</td><td>F36 PHS L2 LOS</td></tr> <tr><td>2</td><td>F2 V LIM FLT</td><td>37</td><td>F37 PHS L3 LOS</td></tr> <tr><td>3</td><td>F3 PDINT FLT</td><td>38</td><td>F38 ENCOD LOST</td></tr> <tr><td>4</td><td>F4 OVERLOAD U+</td><td>40</td><td>F40 PTC EXT</td></tr> <tr><td>5</td><td>F5 OVERLOAD U-</td><td>41</td><td>F41 COMMS TRIP</td></tr> <tr><td>6</td><td>F6 OVERLOAD V+</td><td>42</td><td>F42 AIN1 LOSS</td></tr> <tr><td>7</td><td>F7 OVERLOAD V-</td><td>43</td><td>F43 AIN2 LOSS</td></tr> <tr><td>8</td><td>F8 OVERLOAD W+</td><td>44</td><td>F44 CAL FLT</td></tr> <tr><td>9</td><td>F9 OVERLOAD W-</td><td>45</td><td>F45 STOP T/O</td></tr> <tr><td>10</td><td>F10 SAFE STOP</td><td>46</td><td>F46 EEPROM FLT</td></tr> <tr><td>11</td><td>F11 VIN LOSS</td><td>47</td><td>F47 COMMS T/O</td></tr> <tr><td>12</td><td>F12 IMB V IN</td><td>48</td><td>F48 SPI COM</td></tr> <tr><td>13</td><td>F13 HI V IN</td><td>49</td><td>F49 SPD LIMIT MAX</td></tr> <tr><td>14</td><td>F14 LW V IN</td><td>50</td><td>F50 PSU FAULT</td></tr> <tr><td>15</td><td>F15 CURL Vdc</td><td>51</td><td>F51 SCR TEMP</td></tr> <tr><td>16</td><td>F16 HI Vdc</td><td>52</td><td>F52 FAN P.SUPP</td></tr> <tr><td>17</td><td>F17 LW Vdc</td><td>53</td><td>F53 INTRNL TEMP</td></tr> <tr><td>18</td><td>F18 IMB V OUT</td><td>54</td><td>F54 WATCHDOG</td></tr> <tr><td>19</td><td>F19 IMB I OUT</td><td>55</td><td>F55 DO Feedbck</td></tr> <tr><td>20</td><td>F20 GROUND FLT</td><td>56</td><td>F56 EMERG.STOP</td></tr> <tr><td>21</td><td>F21 I LIM T/O</td><td>57</td><td>F57 PUMP OvLd</td></tr> <tr><td>22</td><td>F22 TQ LIM T/O</td><td>58</td><td>F58 PROFIT.OUT</td></tr> <tr><td>23</td><td>F23 Min Spd.Lm</td><td>60</td><td>F60 EIP/DN T.O</td></tr> <tr><td>25</td><td>F25 MTR O/L</td><td>61</td><td>F61 NO INPUT V</td></tr> <tr><td>27</td><td>F27 DL SMTH</td><td>73</td><td>F73 FLT COMP 1</td></tr> <tr><td>28</td><td>F28 Ir.LIM TO</td><td>74</td><td>F74 FLT COMP 2</td></tr> <tr><td>29</td><td>F29 DSP FLT</td><td>75</td><td>F75 FLT COMP 3</td></tr> <tr><td>30</td><td>F30 WATCHDOG</td><td>76</td><td>F76 SLAVE O.F</td></tr> <tr><td>31</td><td>F31 SCR L1</td><td>77</td><td>OPT FIB TO</td></tr> <tr><td>32</td><td>F32 SCR L2</td><td>78</td><td>F78 TMP FREMAQ</td></tr> <tr><td>33</td><td>F33 SCR L3</td><td></td><td></td></tr> <tr><td>34</td><td>F34 IGBT TEMP</td><td></td><td></td></tr> </tbody> </table>	COD	FAULT	COD	FAULT	0	F0 NO FAULT	35	F35 PHS L1 LOS	1	F1 I LIM FLT	36	F36 PHS L2 LOS	2	F2 V LIM FLT	37	F37 PHS L3 LOS	3	F3 PDINT FLT	38	F38 ENCOD LOST	4	F4 OVERLOAD U+	40	F40 PTC EXT	5	F5 OVERLOAD U-	41	F41 COMMS TRIP	6	F6 OVERLOAD V+	42	F42 AIN1 LOSS	7	F7 OVERLOAD V-	43	F43 AIN2 LOSS	8	F8 OVERLOAD W+	44	F44 CAL FLT	9	F9 OVERLOAD W-	45	F45 STOP T/O	10	F10 SAFE STOP	46	F46 EEPROM FLT	11	F11 VIN LOSS	47	F47 COMMS T/O	12	F12 IMB V IN	48	F48 SPI COM	13	F13 HI V IN	49	F49 SPD LIMIT MAX	14	F14 LW V IN	50	F50 PSU FAULT	15	F15 CURL Vdc	51	F51 SCR TEMP	16	F16 HI Vdc	52	F52 FAN P.SUPP	17	F17 LW Vdc	53	F53 INTRNL TEMP	18	F18 IMB V OUT	54	F54 WATCHDOG	19	F19 IMB I OUT	55	F55 DO Feedbck	20	F20 GROUND FLT	56	F56 EMERG.STOP	21	F21 I LIM T/O	57	F57 PUMP OvLd	22	F22 TQ LIM T/O	58	F58 PROFIT.OUT	23	F23 Min Spd.Lm	60	F60 EIP/DN T.O	25	F25 MTR O/L	61	F61 NO INPUT V	27	F27 DL SMTH	73	F73 FLT COMP 1	28	F28 Ir.LIM TO	74	F74 FLT COMP 2	29	F29 DSP FLT	75	F75 FLT COMP 3	30	F30 WATCHDOG	76	F76 SLAVE O.F	31	F31 SCR L1	77	OPT FIB TO	32	F32 SCR L2	78	F78 TMP FREMAQ	33	F33 SCR L3			34	F34 IGBT TEMP			-
COD	FAULT	COD		FAULT																																																																																																																																								
0	F0 NO FAULT	35		F35 PHS L1 LOS																																																																																																																																								
1	F1 I LIM FLT	36		F36 PHS L2 LOS																																																																																																																																								
2	F2 V LIM FLT	37		F37 PHS L3 LOS																																																																																																																																								
3	F3 PDINT FLT	38		F38 ENCOD LOST																																																																																																																																								
4	F4 OVERLOAD U+	40		F40 PTC EXT																																																																																																																																								
5	F5 OVERLOAD U-	41	F41 COMMS TRIP																																																																																																																																									
6	F6 OVERLOAD V+	42	F42 AIN1 LOSS																																																																																																																																									
7	F7 OVERLOAD V-	43	F43 AIN2 LOSS																																																																																																																																									
8	F8 OVERLOAD W+	44	F44 CAL FLT																																																																																																																																									
9	F9 OVERLOAD W-	45	F45 STOP T/O																																																																																																																																									
10	F10 SAFE STOP	46	F46 EEPROM FLT																																																																																																																																									
11	F11 VIN LOSS	47	F47 COMMS T/O																																																																																																																																									
12	F12 IMB V IN	48	F48 SPI COM																																																																																																																																									
13	F13 HI V IN	49	F49 SPD LIMIT MAX																																																																																																																																									
14	F14 LW V IN	50	F50 PSU FAULT																																																																																																																																									
15	F15 CURL Vdc	51	F51 SCR TEMP																																																																																																																																									
16	F16 HI Vdc	52	F52 FAN P.SUPP																																																																																																																																									
17	F17 LW Vdc	53	F53 INTRNL TEMP																																																																																																																																									
18	F18 IMB V OUT	54	F54 WATCHDOG																																																																																																																																									
19	F19 IMB I OUT	55	F55 DO Feedbck																																																																																																																																									
20	F20 GROUND FLT	56	F56 EMERG.STOP																																																																																																																																									
21	F21 I LIM T/O	57	F57 PUMP OvLd																																																																																																																																									
22	F22 TQ LIM T/O	58	F58 PROFIT.OUT																																																																																																																																									
23	F23 Min Spd.Lm	60	F60 EIP/DN T.O																																																																																																																																									
25	F25 MTR O/L	61	F61 NO INPUT V																																																																																																																																									
27	F27 DL SMTH	73	F73 FLT COMP 1																																																																																																																																									
28	F28 Ir.LIM TO	74	F74 FLT COMP 2																																																																																																																																									
29	F29 DSP FLT	75	F75 FLT COMP 3																																																																																																																																									
30	F30 WATCHDOG	76	F76 SLAVE O.F																																																																																																																																									
31	F31 SCR L1	77	OPT FIB TO																																																																																																																																									
32	F32 SCR L2	78	F78 TMP FREMAQ																																																																																																																																									
33	F33 SCR L3																																																																																																																																											
34	F34 IGBT TEMP																																																																																																																																											
2 F0 NO FAULT FIFTH FLT=FXX	G13.2 / Register 2 of fault history	-		-																																																																																																																																								
3 F0 NO FAULT FOURTH FLT=FXX	G13.3 / Register 3 of fault history	-		-																																																																																																																																								
4 F0 NO FAULT THIRD FLT=FXX	G13.4 / Register 4 of fault history	-		-																																																																																																																																								
5 F0 NO FAULT SECOND FLT=FXX	G13.5 / Register 5 of fault history	-		-																																																																																																																																								
6 F0 NO FAULT FIRST FLT=FXX	G13.6 / Register 6 of fault history	-		-																																																																																																																																								
7 CLEAR FAULTS=N	G13.7 / Erase fault history	N Y	<table border="1"> <thead> <tr> <th>OPT.</th> <th>FUNCTION</th> </tr> </thead> <tbody> <tr> <td>N=NO</td> <td>Function disabled.</td> </tr> <tr> <td>Y=YES</td> <td>It erases fault history (last six faults). The screen returns to default value 'NO', after all the faults have been erased.</td> </tr> </tbody> </table>	OPT.	FUNCTION	N=NO	Function disabled.	Y=YES	It erases fault history (last six faults). The screen returns to default value 'NO', after all the faults have been erased.	YES																																																																																																																																		
OPT.	FUNCTION																																																																																																																																											
N=NO	Function disabled.																																																																																																																																											
Y=YES	It erases fault history (last six faults). The screen returns to default value 'NO', after all the faults have been erased.																																																																																																																																											

4.14. Group 14 – G14: Multi-references

Parameter / Default Value	Name / Description	Range	Function	Set on RUN																																								
1 MREF 1=+10.0% MULTI-REFERENCE1	G14.1 / Multi-reference 1	-250% to +250%	<p>It allows setting of multiple references. These references will be activated using digital inputs configured as multiple speed references or PID references. To use this function select operating mode, 'G4.1.4 DIGIT I MODE=2 or 3' (2 or 3-wires multi-reference). It is necessary to select the multi-references as the speed reference in parameter 'G3.1 REF 1 SPD=MREF' or as a PID references in 'G6.1 SEL REF=MREF'.</p> <p>Units are set in either percentage of motor rated speed or feedback analogue input range (if an analogue unit is selected).</p> <p>The following table shows the relationship between DI4, DI5, DI6 inputs when activated in multi-reference mode (as a percentage of motor rated speed):</p> <table border="1"> <thead> <tr> <th>PARAM</th> <th>REF</th> <th>DI4</th> <th>DI5</th> <th>DI6</th> </tr> </thead> <tbody> <tr> <td>G14.1</td> <td>MREF 1</td> <td>0</td> <td>0</td> <td>X</td> </tr> <tr> <td>G14.2</td> <td>MREF 2</td> <td>0</td> <td>X</td> <td>0</td> </tr> <tr> <td>G14.3</td> <td>MREF 3</td> <td>0</td> <td>X</td> <td>X</td> </tr> <tr> <td>G14.4</td> <td>MREF 4</td> <td>X</td> <td>0</td> <td>0</td> </tr> <tr> <td>G14.5</td> <td>MREF 5</td> <td>X</td> <td>0</td> <td>X</td> </tr> <tr> <td>G14.6</td> <td>MREF 6</td> <td>X</td> <td>X</td> <td>0</td> </tr> <tr> <td>G14.7</td> <td>MREF 7</td> <td>X</td> <td>X</td> <td>X</td> </tr> </tbody> </table> <p>Note: 0: Not active and X: Active.</p>	PARAM	REF	DI4	DI5	DI6	G14.1	MREF 1	0	0	X	G14.2	MREF 2	0	X	0	G14.3	MREF 3	0	X	X	G14.4	MREF 4	X	0	0	G14.5	MREF 5	X	0	X	G14.6	MREF 6	X	X	0	G14.7	MREF 7	X	X	X	YES
PARAM	REF			DI4	DI5	DI6																																						
G14.1	MREF 1			0	0	X																																						
G14.2	MREF 2			0	X	0																																						
G14.3	MREF 3			0	X	X																																						
G14.4	MREF 4			X	0	0																																						
G14.5	MREF 5			X	0	X																																						
G14.6	MREF 6	X	X	0																																								
G14.7	MREF 7	X	X	X																																								
2 MREF 2=+20.0% MULTI-REFERENCE2	G14.2 / Multi-reference 2																																											
3 MREF 3=+30.0% MULTI-REFERENCE3	G14.3 / Multi-reference 3																																											
4 MREF 4=+40.0% MULTI-REFERENCE4	G14.4 / Multi-reference 4																																											
5 MREF 5=+50.0% MULTI-REFERENCE5	G14.5 / Multi-reference 5																																											
6 MREF 6=+60.0% MULTI-REFERENCE6	G14.6 / Multi-reference 6																																											
7 MREF 7=+70.0% MULTI-REFERENCE7	G14.7 / Multi-reference 7																																											

4.15. Group 15 – G15: Inch Speeds

Parameter / Default Value	Name / Description	Range	Function	Set on RUN														
1 INCH1=+0.00% INCH SPEED 1	G15.1 / Inch speed 1	-250% to +250%	<p>Allows setting of the value of the three possible motor inch speeds. Inch speed selection is possible through a comparator output (directly) or by a digital input combination. If digital inputs are used for this purpose they should be configured as 'START + INCH1' or 'START + INCH2'. See G4.1.5 to G4.1.10.</p> <table border="1"> <thead> <tr> <th rowspan="2">Speed</th> <th colspan="2">Inputs</th> </tr> <tr> <th>DIX</th> <th>DIY</th> </tr> </thead> <tbody> <tr> <td>Inch speed 1</td> <td>X</td> <td>0</td> </tr> <tr> <td>Inch speed 2</td> <td>0</td> <td>X</td> </tr> <tr> <td>Inch speed 3</td> <td>X</td> <td>X</td> </tr> </tbody> </table> <p>Note: The activation of this function includes the start command. Therefore this signal has priority over any other input configured as 'Start'.</p>	Speed	Inputs		DIX	DIY	Inch speed 1	X	0	Inch speed 2	0	X	Inch speed 3	X	X	YES
Speed	Inputs																	
	DIX			DIY														
Inch speed 1	X	0																
Inch speed 2	0	X																
Inch speed 3	X	X																
2 INCH2=+0.00% INCH SPEED 2	G15.2 / Inch speed 2																	
3 INCH3=+0.00% INCH SPEED 3	G15.3 / Inch speed 3																	

4.16. Group 16 – G16: Skip Frequencies

Parameter / Default Value	Name / Description	Range	Function	Set on RUN
1 SKIP 1=+0.0% SKIP FREQUENCY 1	G16.1 / Skip frequency 1	-250% to +250%	Allows user to select the first skip frequency to avoid resonance frequencies or frequencies where it is not desirable for the motor to operate. Drive passes through this frequency value during acceleration and/or deceleration but will not remain operating at this frequency. Once this value is set, the bandwidth (G16.3) will be based on it, forming a frequency range that the drive will avoid.	YES
2 SKIP 2=+0.0% SKIP FREQUENCY 2	G16.2 / Skip frequency 2	-250% to +250%	Allows user to select the second skip frequency to avoid resonance frequencies or frequencies where it is not desirable for the motor to operate. Drive passes through this frequency value during acceleration and/or deceleration but will not remain operating at this frequency. Once this value is set, the bandwidth (G16.3) will be based on it, forming a frequency range that the drive will avoid.	YES

Parameter / Default Value	Name / Description	Range	Function	Set on RUN
3 SKIP BAND=OFF OFFSET BAND	G16.3 / Skip bandwidth	OFF=0 to 20%	Sets the skip frequency bandwidth. For example, if 10% is set, the avoided frequencies will be from freq (G16.1) – 5% to freq(G16.1) + 5% and from freq(G16.2) – 5% to freq(G16.2) + 5%. Supposing that the selected range goes from 20% to 30%. In case of the frequency is within that band, for example 27%, there is two situations: a) Drive is accelerating: so the frequency will be increased up to 27%, but it will not remain here, it will be increased up to 30%. b) Drive is decelerating: so the frequency will be decreased down to 27%, but it will not remain here, it will be decreased down to 20%.	YES

4.17. Group 17 – G17: Brake

Parameter / Default Value	Name / Description	Range	Function	Set on RUN						
1 T DC BRAKE=OFF DC BRAKING TIME	G17.1 / Time for DC brake activation	OFF=0.0 to 99s	Allows setting of the time for which the DC brake will be activated.	YES						
2 DC CURR=0% DC CURRENT LEVEL	G17.2 / Current applied to the brake	0 – 100%	Allows setting of the current level applied during braking. The proper current value must be set to brake the load inertia correctly. If this value is too much low the load will not be stopped in time. If the value is too high the power components of the drive will be stressed.	YES						
3 DC VOLTS=0.0% DC BR VOLT LEVEL	G17.3 / Voltage applied to the brake	0.0 – 25%	Allows setting of the continuous DC voltage level applied during braking. The proper voltage value must be set to brake the load inertia correctly. If this value is too much low load will not be stopped in time. Otherwise, if the value is too high the power components of the drive will be stressed.	YES						
4 I HEATING=OFF Idc HEATING	G17.4 / Non condensing heating current	OFF=0.0 to 30%	Set a suitable value to avoid humidity or condensation forming in the motor. Note: Modify this parameter only if necessary.  CAUTION: Although the motor is not running there is dangerous voltage. Run Led will be lit during this process. Be careful to avoid property damage and personal injuries.	YES						
5 DYN BRAK=N	G17.5 / Use of external brake	N Y	User must configure the drive if an external dynamic brake is going to be used. <table border="1" data-bbox="730 1182 1264 1256"> <thead> <tr> <th>OPT.</th> <th>FUNCTION</th> </tr> </thead> <tbody> <tr> <td>N=NO</td> <td>External brake is not used.</td> </tr> <tr> <td>Y=YES</td> <td>External brake is going to be installed.</td> </tr> </tbody> </table>	OPT.	FUNCTION	N=NO	External brake is not used.	Y=YES	External brake is going to be installed.	NO
OPT.	FUNCTION									
N=NO	External brake is not used.									
Y=YES	External brake is going to be installed.									

4.18. Group 18 – G18: Encoder

Parameter / Default Value	Name / Description	Range	Function	Set on RUN						
0 ENCODER =N	G18.0 / Encoder	N Y	<table border="1" data-bbox="730 1451 1264 1525"> <thead> <tr> <th>OPT</th> <th>FUNCTION</th> </tr> </thead> <tbody> <tr> <td>N</td> <td>The Encoder is enabled</td> </tr> <tr> <td>Y</td> <td>The Encoder is disabled</td> </tr> </tbody> </table>	OPT	FUNCTION	N	The Encoder is enabled	Y	The Encoder is disabled	YES
OPT	FUNCTION									
N	The Encoder is enabled									
Y	The Encoder is disabled									
1 PULSES=1024	G18.1 / Pulses per revolution of the encoder	200 to 8191	Set the encoder installed in the motor pulses per revolution	NO						
2 TYPE=DIFF	G18.2 / Encoder Type	DIFF SING	Select the type of encoder installed in the motor <table border="1" data-bbox="730 1630 1264 1704"> <thead> <tr> <th>OPT.</th> <th>FUNCTION</th> </tr> </thead> <tbody> <tr> <td>DIFF</td> <td>Differential output encoder</td> </tr> <tr> <td>SING</td> <td>Single-ended output encoder</td> </tr> </tbody> </table>	OPT.	FUNCTION	DIFF	Differential output encoder	SING	Single-ended output encoder	NO
OPT.	FUNCTION									
DIFF	Differential output encoder									
SING	Single-ended output encoder									
3 ENCOD FILTER=N	G18.3/ Encoder filter selection	N Y	Filters the encoder signal	NO						

4.19. Group 19 – G19: Fine Tuning

4.19.1. Subgroup 19.1 – S19.1: IGBT Control

Parameter / Default Value	Name / Description	Range	Function	Set on RUN										
1 TYPE CTRL=V/Hz	G19.1.1 / Selection of control type	V/Hz VECT	This selection defines the drive control type. <table border="1"> <thead> <tr> <th>OPT.</th> <th>FUNCTION</th> </tr> </thead> <tbody> <tr> <td>V/Hz</td> <td>Scalar control mode. Drive carries out the control applying a voltage / frequency ramp to the motor.</td> </tr> <tr> <td>VECT</td> <td>Vector Control.</td> </tr> </tbody> </table>	OPT.	FUNCTION	V/Hz	Scalar control mode. Drive carries out the control applying a voltage / frequency ramp to the motor.	VECT	Vector Control.	YES				
OPT.	FUNCTION													
V/Hz	Scalar control mode. Drive carries out the control applying a voltage / frequency ramp to the motor.													
VECT	Vector Control.													
2 VECTOR CTR = PMC (* Available if G19.1.1 = VECT	G19.1.2 / Vector Control mode	PMC AVC	Set the vector control mode: <table border="1"> <thead> <tr> <th>OPT.</th> <th>FUNCTION</th> </tr> </thead> <tbody> <tr> <td>PMC</td> <td>Power Motor Control.</td> </tr> <tr> <td>AVC</td> <td>Advance Vector Control.</td> </tr> </tbody> </table>	OPT.	FUNCTION	PMC	Power Motor Control.	AVC	Advance Vector Control.	NO				
OPT.	FUNCTION													
PMC	Power Motor Control.													
AVC	Advance Vector Control.													
3 PMC = OL SP (* Available if G19.1.1 = VECT and G19.1.2 = PMC	G19.1.3 / Power Motor Control mode	OL SP OL TQ CL SP CL TQ	Set the Power Motor Control mode: <table border="1"> <thead> <tr> <th>OPT.</th> <th>FUNCTION</th> </tr> </thead> <tbody> <tr> <td>OL SP</td> <td>Open Loop Speed Control.</td> </tr> <tr> <td>OL TQ</td> <td>Open Loop Torque Control.</td> </tr> <tr> <td>CL SP</td> <td>Close Loop Speed Control.</td> </tr> <tr> <td>CL TQ</td> <td>Close Loop Torque Control.</td> </tr> </tbody> </table>	OPT.	FUNCTION	OL SP	Open Loop Speed Control.	OL TQ	Open Loop Torque Control.	CL SP	Close Loop Speed Control.	CL TQ	Close Loop Torque Control.	NO
OPT.	FUNCTION													
OL SP	Open Loop Speed Control.													
OL TQ	Open Loop Torque Control.													
CL SP	Close Loop Speed Control.													
CL TQ	Close Loop Torque Control.													
4 AVC = CL SP (* Available if G19.1.1 = VECT and G19.1.2 = AVC	G19.1.4 / Advance Vector Control mode	CL SP CL TQ	Set the Advance Vector Control mode: <table border="1"> <thead> <tr> <th>OPT.</th> <th>FUNCTION</th> </tr> </thead> <tbody> <tr> <td>CL SP</td> <td>Close Loop Speed Control.</td> </tr> <tr> <td>CL TQ</td> <td>Close Loop Torque Control.</td> </tr> </tbody> </table>	OPT.	FUNCTION	CL SP	Close Loop Speed Control.	CL TQ	Close Loop Torque Control.	NO				
OPT.	FUNCTION													
CL SP	Close Loop Speed Control.													
CL TQ	Close Loop Torque Control.													
5 FREQ=4000Hz MODULAT FREQUENC	G19.1.5 / Commutation frequency	4000 – 8000 Hz	It allows modification of the drive switching frequency. This function can be used to reduce audible motor noise.	YES										
6 PEWAVE=Y	G19.1.6 / Pewave control	N Y	This control mode improves motor noise tone. <table border="1"> <thead> <tr> <th>OPT.</th> <th>FUNCTION</th> </tr> </thead> <tbody> <tr> <td>N=NO</td> <td>Pewave control deactivated.</td> </tr> <tr> <td>Y=YES</td> <td>Pewave control activated. Commutation frequency (G19.1.2) is slightly modified on a random basis to improve the noise tone generated by the motor.</td> </tr> </tbody> </table>	OPT.	FUNCTION	N=NO	Pewave control deactivated.	Y=YES	Pewave control activated. Commutation frequency (G19.1.2) is slightly modified on a random basis to improve the noise tone generated by the motor.	YES				
OPT.	FUNCTION													
N=NO	Pewave control deactivated.													
Y=YES	Pewave control activated. Commutation frequency (G19.1.2) is slightly modified on a random basis to improve the noise tone generated by the motor.													
8 Autotune=N	G19.1.8 / Motor parameter auto-tuning	N Y	This selection allows executing a motor auto-tuning, in order to get the stator resistance value of the motor. This value will be saved in parameter G19.3.1.	YES										
9 OVERMODULATIO=N	G.19.1.9 / Over-modulation	N Y	With this option, it allows supplying more motor voltage at 50Hz.	YES										

4.19.2. Subgroup 19.2 – S19.2: Motor Load

Parameter / Default Value	Name / Description	Range	Function	Set on RUN
1 MIN FLUX = 100% MINIMUM FLUX	G19.2.1 / Minimum Flux	40 – 100%	Allows setting of the minimum flux level used by the motor during low load conditions. With this dynamic system of flux optimization, noise and power losses are reduced. Adaptation of the flux level during low load conditions occurs automatically. The algorithm will be disabled when this parameter is set to 100%.	YES
3 V BOOST = 0.0%	G19.2.3 / Initial voltage	0.0 to 100%	Sets an initial voltage value applied to the motor during the starting. Using this function it is possible to improve breakaway torque when starting heavy loads. Note: Set a low value first. Increase the value gradually until the load starts easily.	YES
4 SLIP COMPENS=N	G19.2.4 / Slip compensation	N Y	If this function is active, it helps to compensate the slip on the motor. In case of heavy load able of provoking a high slip during the starting, set this parameter to YES.	YES

Parameter / Default Value	Name / Description	Range	Function	Set on RUN																																																																		
7 I SLIP=2.0%(*) I SLIP COMPENSAT	G19.2.7 / Current limit factor	0.0 – 20.0%	<p>Modifies the speed by reducing the output frequency to keep the output current within a controllable margins (display shows ILT). Adjusting this parameter can improve the stability of the current limit function taking the motor slip into account. Note: The following table shows the default values for drives of any nominal voltage.</p> <table border="1" style="margin-left: auto; margin-right: auto;"> <thead> <tr> <th colspan="2">Default Values for All Powers</th> </tr> <tr> <th>G2.3 Motor Power (kW)</th> <th>Value (%)</th> </tr> </thead> <tbody> <tr><td>2.2</td><td>5.30</td></tr> <tr><td>4</td><td>4.30</td></tr> <tr><td>5.5</td><td>4.00</td></tr> <tr><td>7.5</td><td>3.80</td></tr> <tr><td>11</td><td>3.50</td></tr> <tr><td>15</td><td>3.10</td></tr> <tr><td>18.5</td><td>2.90</td></tr> <tr><td>22</td><td>2.67</td></tr> <tr><td>30</td><td>2.16</td></tr> <tr><td>37</td><td>2.10</td></tr> <tr><td>45</td><td>1.90</td></tr> <tr><td>55</td><td>1.87</td></tr> <tr><td>75</td><td>1.60</td></tr> <tr><td>90</td><td>1.50</td></tr> <tr><td>110</td><td>1.36</td></tr> <tr><td>132</td><td>1.20</td></tr> <tr><td>150</td><td>1.09</td></tr> <tr><td>160</td><td>1.03</td></tr> <tr><td>200</td><td>0.79</td></tr> <tr><td>250</td><td>0.75</td></tr> <tr><td>315</td><td>0.70</td></tr> <tr><td>355</td><td>0.65</td></tr> <tr><td>400</td><td>0.60</td></tr> <tr><td>450</td><td>0.52</td></tr> <tr><td>500</td><td>0.46</td></tr> <tr><td>560</td><td>0.43</td></tr> <tr><td>630</td><td>0.35</td></tr> <tr><td>710</td><td>0.40</td></tr> <tr><td>800</td><td>0.32</td></tr> <tr><td>900</td><td>0.30</td></tr> <tr><td>1000</td><td>0.25</td></tr> </tbody> </table> <p>* Adjust mode: When initializing factory settings (1) or manually modifying the Motor Nominal Power (G2.3) (2). The value of the current limit factor is initialized according to the table. Values outside the table are estimated according to the table. In all cases the adjustment range is + / -30% of initialized value in any of the two scenarios given (1) and (2). Note: We recommend this value is adjusted only when the current limit action is unstable. A low value will improve the stability although the current limit action will operate earlier.</p>	Default Values for All Powers		G2.3 Motor Power (kW)	Value (%)	2.2	5.30	4	4.30	5.5	4.00	7.5	3.80	11	3.50	15	3.10	18.5	2.90	22	2.67	30	2.16	37	2.10	45	1.90	55	1.87	75	1.60	90	1.50	110	1.36	132	1.20	150	1.09	160	1.03	200	0.79	250	0.75	315	0.70	355	0.65	400	0.60	450	0.52	500	0.46	560	0.43	630	0.35	710	0.40	800	0.32	900	0.30	1000	0.25	YES
Default Values for All Powers																																																																						
G2.3 Motor Power (kW)	Value (%)																																																																					
2.2	5.30																																																																					
4	4.30																																																																					
5.5	4.00																																																																					
7.5	3.80																																																																					
11	3.50																																																																					
15	3.10																																																																					
18.5	2.90																																																																					
22	2.67																																																																					
30	2.16																																																																					
37	2.10																																																																					
45	1.90																																																																					
55	1.87																																																																					
75	1.60																																																																					
90	1.50																																																																					
110	1.36																																																																					
132	1.20																																																																					
150	1.09																																																																					
160	1.03																																																																					
200	0.79																																																																					
250	0.75																																																																					
315	0.70																																																																					
355	0.65																																																																					
400	0.60																																																																					
450	0.52																																																																					
500	0.46																																																																					
560	0.43																																																																					
630	0.35																																																																					
710	0.40																																																																					
800	0.32																																																																					
900	0.30																																																																					
1000	0.25																																																																					
9 STR FRQ = 0.0% START FREQUENCY	G19.2.9 / Initial frequency	0.0% to 100%	Allows setting of an initial frequency that will be applied from the drive at the moment of starting.	YES																																																																		
11 DAMPref=3% REFER.DAMPING	G19.2.11 / Damping reference	0.0 to 10.0%	In some motors, instable behaviours are generated at some frequencies when the motors are connected with no load. Set this parameter will control the instability.	YES																																																																		
13 CT Vbus=800 REGEN BUS VOL	G19.2.13 / Regeneration bus voltage	For Vin = 230v, 390 to 410 For VIN = 400V / 500V 625 to 800V For VIN = 690V 950 to 1251V	During the deceleration with loads with inertia, the drive decelerates keeping the level of the bus voltage set by this parameter, when load and inertia conditions allow it. If when decelerating, the fault 'F2 V LIM FLT', decrease the value of this parameter.	YES																																																																		

4.19.3. Subgroup 19.3 – S19.3: Motor Model

Parameter / Default Value	Name / Description	Range	Function	Set on RUN																																																																																																																																				
1 R. STR=1% STATOR RESISTOR	G19.3.1 / Stator resistance (Rs)	0.0 to 9.9%	Set as a percentage of motor rated impedance.																																																																																																																																					
2 R. RTR = 0%	G19.3.2 / Rotor resistance (Rr)	0.0% to 15%	Stator resistance (Rs): It is used to compensate the iron losses and copper losses of the motor.																																																																																																																																					
3 Lm = 40%	G19.3.3 / Motor inductance (Lm)	40% to 800%	Rotor resistance (Rr): A key parameter that directly concerns the output torque.																																																																																																																																					
			Motor inductance (Lm): It is an interesting parameter if the equipment works with vector control and G19.1.2 = AVC. It is the main inductance of the motor that defines the magnetic field strength. It is a key parameter that directly concerns the motor flux. Typical values can range from 75% (small motors) to 800% (large motors).																																																																																																																																					
4 L.I. = 0%	G19.3.4 / Stray inductance	0.0% to 50%	<p>Note: The following table shows the default values for drives of any nominal voltage.</p> <table border="1"> <thead> <tr> <th colspan="4">Default Values for All Powers</th> </tr> <tr> <th>G2.3- Motor Power (kW)</th> <th>Value G19.3.1 (%)</th> <th>Value G19.3.2 (%)</th> <th>Value G19.3.3 (%)</th> </tr> </thead> <tbody> <tr><td>2.2</td><td>5.30</td><td>5.30</td><td>100</td></tr> <tr><td>4</td><td>4.30</td><td>4.30</td><td>100</td></tr> <tr><td>5.5</td><td>4.00</td><td>4.00</td><td>100</td></tr> <tr><td>7.5</td><td>3.80</td><td>3.80</td><td>100</td></tr> <tr><td>11</td><td>3.50</td><td>3.50</td><td>100</td></tr> <tr><td>15</td><td>3.10</td><td>3.10</td><td>100</td></tr> <tr><td>18.5</td><td>2.90</td><td>2.90</td><td>100</td></tr> <tr><td>22</td><td>2.67</td><td>2.67</td><td>100</td></tr> <tr><td>30</td><td>2.16</td><td>2.16</td><td>250</td></tr> <tr><td>37</td><td>2.10</td><td>2.10</td><td>250</td></tr> <tr><td>45</td><td>1.90</td><td>1.90</td><td>250</td></tr> <tr><td>55</td><td>1.87</td><td>1.87</td><td>250</td></tr> <tr><td>75</td><td>1.60</td><td>1.60</td><td>250</td></tr> <tr><td>90</td><td>1.50</td><td>1.50</td><td>250</td></tr> <tr><td>110</td><td>1.36</td><td>1.36</td><td>250</td></tr> <tr><td>132</td><td>1.20</td><td>1.20</td><td>250</td></tr> <tr><td>150</td><td>1.09</td><td>1.09</td><td>250</td></tr> <tr><td>160</td><td>1.03</td><td>1.03</td><td>450</td></tr> <tr><td>200</td><td>0.79</td><td>0.79</td><td>450</td></tr> <tr><td>250</td><td>0.75</td><td>0.75</td><td>450</td></tr> <tr><td>315</td><td>0.70</td><td>0.70</td><td>450</td></tr> <tr><td>355</td><td>0.65</td><td>0.65</td><td>450</td></tr> <tr><td>400</td><td>0.60</td><td>0.60</td><td>450</td></tr> <tr><td>450</td><td>0.52</td><td>0.52</td><td>450</td></tr> <tr><td>500</td><td>0.46</td><td>0.46</td><td>450</td></tr> <tr><td>560</td><td>0.43</td><td>0.43</td><td>450</td></tr> <tr><td>630</td><td>0.35</td><td>0.35</td><td>450</td></tr> <tr><td>710</td><td>0.40</td><td>0.40</td><td>450</td></tr> <tr><td>800</td><td>0.32</td><td>0.32</td><td>450</td></tr> <tr><td>900</td><td>0.30</td><td>0.30</td><td>450</td></tr> <tr><td>1000</td><td>0.25</td><td>0.25</td><td>450</td></tr> </tbody> </table> <p>G19.3.4 = 5% of G19.3.3</p> <p>Adjust mode: When initializing factory settings (1) or manually modifying the Motor Nominal Power (G2.3) (2), the values are initialized according to the table, values outside the table are estimated according to the table. When auto-tuning is performed (G19.1.8) (3) the value of parameters is automatically changed to the value measured. In all cases, the adjustment range is + / -30% of initialized value in any of the three scenarios given (1), (2), (3).</p> <p>Note: If this G19.3.1 is set too high then increased motor currents can reach the current limit preventing further acceleration to the motor. We recommend consulting the above standard value table as Rs value is variable according to the drive capacity.</p>	Default Values for All Powers				G2.3- Motor Power (kW)	Value G19.3.1 (%)	Value G19.3.2 (%)	Value G19.3.3 (%)	2.2	5.30	5.30	100	4	4.30	4.30	100	5.5	4.00	4.00	100	7.5	3.80	3.80	100	11	3.50	3.50	100	15	3.10	3.10	100	18.5	2.90	2.90	100	22	2.67	2.67	100	30	2.16	2.16	250	37	2.10	2.10	250	45	1.90	1.90	250	55	1.87	1.87	250	75	1.60	1.60	250	90	1.50	1.50	250	110	1.36	1.36	250	132	1.20	1.20	250	150	1.09	1.09	250	160	1.03	1.03	450	200	0.79	0.79	450	250	0.75	0.75	450	315	0.70	0.70	450	355	0.65	0.65	450	400	0.60	0.60	450	450	0.52	0.52	450	500	0.46	0.46	450	560	0.43	0.43	450	630	0.35	0.35	450	710	0.40	0.40	450	800	0.32	0.32	450	900	0.30	0.30	450	1000	0.25	0.25	450	YES
Default Values for All Powers																																																																																																																																								
G2.3- Motor Power (kW)	Value G19.3.1 (%)	Value G19.3.2 (%)	Value G19.3.3 (%)																																																																																																																																					
2.2	5.30	5.30	100																																																																																																																																					
4	4.30	4.30	100																																																																																																																																					
5.5	4.00	4.00	100																																																																																																																																					
7.5	3.80	3.80	100																																																																																																																																					
11	3.50	3.50	100																																																																																																																																					
15	3.10	3.10	100																																																																																																																																					
18.5	2.90	2.90	100																																																																																																																																					
22	2.67	2.67	100																																																																																																																																					
30	2.16	2.16	250																																																																																																																																					
37	2.10	2.10	250																																																																																																																																					
45	1.90	1.90	250																																																																																																																																					
55	1.87	1.87	250																																																																																																																																					
75	1.60	1.60	250																																																																																																																																					
90	1.50	1.50	250																																																																																																																																					
110	1.36	1.36	250																																																																																																																																					
132	1.20	1.20	250																																																																																																																																					
150	1.09	1.09	250																																																																																																																																					
160	1.03	1.03	450																																																																																																																																					
200	0.79	0.79	450																																																																																																																																					
250	0.75	0.75	450																																																																																																																																					
315	0.70	0.70	450																																																																																																																																					
355	0.65	0.65	450																																																																																																																																					
400	0.60	0.60	450																																																																																																																																					
450	0.52	0.52	450																																																																																																																																					
500	0.46	0.46	450																																																																																																																																					
560	0.43	0.43	450																																																																																																																																					
630	0.35	0.35	450																																																																																																																																					
710	0.40	0.40	450																																																																																																																																					
800	0.32	0.32	450																																																																																																																																					
900	0.30	0.30	450																																																																																																																																					
1000	0.25	0.25	450																																																																																																																																					
5 FL WEAK = 90%	G19.3.5/ Weakening field	50% to 100%	The weakening field occurs when the drive cannot give more voltage than it receives from the power supply, and when the frequency exceeds the rated frequency of the motor. In this event, only the frequency will be regulated and the voltage will keep constant producing the weakening of the motor field.	YES																																																																																																																																				

4.19.4. Subgroup 19.4 – S19.4: Control PID

Parameter / Default Value	Name / Description	Range	Function	Set on RUN
1 Kp Sp = 95% (* Available if the drive is in speed mode)	G19.4.1 / Speed closed loop proportional constant.	0.0% to 100%	Allows the setting of the proportional gain value of the speed regulator. If a greater control response is needed, this value has to be increased. Note: When increasing too much this value, the system can be destabilized.	YES
2 Ki Sp= 95% (* Available if the drive is in speed mode)	G19.4.2 / Speed closed loop integration time setting.	0.0% to 100%	Allows the adjustment of the integration time of the speed regulator. In the event of needing more precision, this value has to be increased. Note: When increasing this value too much, the system can get slower.	YES
3 Kp Tq = 95% (* Available if the drive is in torque mode)	G19.4.3 / Torque proportional closed loop constant.	0% to 100%	Allows setting the value of the proportional gain of the overcurrent regulator. If a greater control response is needed this value has to be increased. Note: When increasing too much this value, the system can become more unstable.	YES
4 Ki Tq = 95% (* Available if the drive is in torque mode)	G19.4.4 / Torque closed loop time setting.	0% to 100%	Allows the adjustment of the integration time of the overcurrent regulator. In the event of needing more precision, this value has to be increased. Note: When increasing this value too much, the system can get slower.	YES
5 Kp I = 95% (* Available if G19.1.1=VECT and G19.1.2 = PMC)	G19.4.5 / Current closed loop proportional constant	0.0% to 100%	Allows the setting of the proportional gain value of the flow regulator.	NO
6 Ki I = 15% (* Available if G19.1.1=VECT and G19.1.2 = PMC)	G19.4.6 / Current closed loop integration time setting.	0.0% to 100%	Allows the adjustment of the integration time of the flow regulator	NO
9 Flux tune=2.0% (* Available if G19.1.1=VECT and G19.1.2 = PMC)	G19.4.9 / Flux tuning	0.0% to 10%	Allows to set a greater starting torque in the device. Note: Fault "F39 BLOCKED rotor" when giving the boot order means that the device hasn't got enough torque for the load. The user will have to set a higher value. Once this value has been set to its maximum, if the motor doesn't move it will probably mean that the resistant torque is too high for the device, or there is a mechanical problem.	YES

4.20. Group 20 – G20: Communication Buses

4.20.1. Subgroup 20.0 – S20.0: Communications Control

Parameter / Default Value	Name / Description	Range	Function	Set on RUN																
1 COM. CONTROL = 0	G20.0.1 / Communications Control	0-6	Selection of the communication bus through which the equipment is controlled <table border="1" style="margin-left: 20px;"> <thead> <tr> <th>OPC.</th> <th>FUNCIÓN</th> </tr> </thead> <tbody> <tr> <td>0</td> <td>Modbus</td> </tr> <tr> <td>1</td> <td>Profibus</td> </tr> <tr> <td>2</td> <td>Modbus TCP</td> </tr> <tr> <td>3</td> <td>Ethernet IP</td> </tr> <tr> <td>4</td> <td>Can Open</td> </tr> <tr> <td>5</td> <td>Devicenet</td> </tr> <tr> <td>6</td> <td>OFC</td> </tr> </tbody> </table> Note: This parameter is only functional after the boot up.	OPC.	FUNCIÓN	0	Modbus	1	Profibus	2	Modbus TCP	3	Ethernet IP	4	Can Open	5	Devicenet	6	OFC	NO
OPC.	FUNCIÓN																			
0	Modbus																			
1	Profibus																			
2	Modbus TCP																			
3	Ethernet IP																			
4	Can Open																			
5	Devicenet																			
6	OFC																			

4.20.2. Subgroup 20.1 – S20.1: Modbus RTU

Parameter / Default Value	Name / Description	Range	Function	Set on RUN
1 COMMS T/O =OFF COMMS TIMEOUT	G20.1.1 / Communication timeout MODBUS RTU	OFF=0 to 250s	If this time has elapsed from the last valid data transmission a communication timeout trip can be generated if the user requires it. Serial communication with the drive is possible through RS232 terminals, RS485 terminals, or through optional serial communication interfaces. Note: Do not modify this parameter if is not necessary.	YES
2 COMM ADDR =10 COMM ADDRESS	G20.1.2 / Communication address	1 to 255	Sets the identification address assigned to the drive for communication via the Modbus network. If communication is required with several drives a different address is required for each unit.	YES

Parameter / Default Value	Name / Description	Range	Function	Set on RUN
3 BAUDS=9600	G20.1.3 / Communication speed	600 1200 2400 4800 9600 19200	Sets the data transmission speed for MODBUS serial communications. This rating should be the same as the rating of the master of the communication bus on which the drive is integrated.	YES
4 PARITY=NONE	G20.1.4 / Communication parity	ODD NONE EVEN	MODBUS parity setting. Used for data validation. If you do not want to validate data, set this parameter to 'NONE'. Parity selection should be the same as the parity of the master of the communication bus on which the drive is integrated.	YES
DispBR= 4800	Display communication speed	1200 2400 4800 9600	Set the baud rate of the communication between the display and the control power board.	YES

4.20.3. Subgroup 20.2 – S20.2: PROFIBUS (*)

Parameter / Default Value	Name / Description	Range	Function	Set on RUN
1 NODE ADDR=10 NODE ADDRESS	G20.2.1 / Slave address in Profibus network	1 to 255	Sets the identification address assigned to the drive for communication via Profibus network. If communication is required with several drives a different address is required for each unit.	YES

(*) **Note:** Available if G20.0.1 = 1 Profibus

4.20.4. Subgroup 20.3 – S20.3: CANOPEN (*)

Parameter / Default Value	Name / Description	Range	Function	Set on RUN
1 CO NODEID=0	G20.3.1 / Canopen slave address	0 to 127	The Node slave address is assigned	YES
2 CO BAUD=1Mbps	G20.3.2 / Bus speed connected to drive	125Kbps 250Kbps 500Kbps 1Mbps	Set the bus speed at which the drive will be connected.	YES
3 CO REF sp=+0.0%	G20.3.3 / Canopen Speed		Display screen through which the speed referenced can be seen through the Canopen	YES

(*) **Note:** Available if G20.0.1 = 4 CanOpen

4.20.5. Subgroup 20.4 – S20.4: DEVICENET (*)

Parameter / Default Value	Name / Description	Range	Function	Set on RUN								
1 DN MAC ID=0	G20.4.1 / Devicenet MAC ID	0 to 63	DeviceNet MAC ID setting. Each device must be assigned a unique MAC ID within the network. MAC ID can be changed at any time, but it will come into effect after power-cycling the drive. The default value is 0x00..	YES								
2DNBaud=500Kbps	G20.4.2 / Devicenet Baud rate	125Kbps 250Kbps 500Kbps	Choose the DeviceNet Baud Rate (set by Master device) <table border="1" style="margin-left: 20px;"> <thead> <tr> <th>OPTIONS</th> <th>DESCRIPTION</th> </tr> </thead> <tbody> <tr> <td>0</td> <td>125 Kbps</td> </tr> <tr> <td>1</td> <td>250 Kbps</td> </tr> <tr> <td>2</td> <td>500 Kbps</td> </tr> </tbody> </table> DeviceNet Baud Rate can be changed at any time, but it will come into effect after power-cycling the drive.	OPTIONS	DESCRIPTION	0	125 Kbps	1	250 Kbps	2	500 Kbps	YES
OPTIONS	DESCRIPTION											
0	125 Kbps											
1	250 Kbps											
2	500 Kbps											

Parameter / Default Value	Name / Description	Range	Function	Set on RUN														
3 CONTROL MODE=0	G20.4.3 / Control modes	0 to 2	<p>The following table shows the different control modes</p> <table border="1"> <thead> <tr> <th>OPT</th> <th>DESCRIPTION</th> <th>FUNCTION</th> </tr> </thead> <tbody> <tr> <td>0</td> <td>LOCAL</td> <td>The drive control is given in [G4.1.1] or [G4.1.2] parameter</td> </tr> <tr> <td>1</td> <td>NET</td> <td>If the Control Mode 1 parameter [G4.1.1] is active and set to 3 (Comm.), then the drive is operated through DeviceNet. Identically, when Control Mode 2 is active, the value contained in [G4.1.2] parameter determines the way it is finally controlled.</td> </tr> <tr> <td>2</td> <td>NETDECIDES</td> <td>The PLC will decide how the drive is controlled. If it is controlled over network, option 1 will be enabled. However, if the net resigns control, it will be controlled locally.</td> </tr> </tbody> </table>	OPT	DESCRIPTION	FUNCTION	0	LOCAL	The drive control is given in [G4.1.1] or [G4.1.2] parameter	1	NET	If the Control Mode 1 parameter [G4.1.1] is active and set to 3 (Comm.), then the drive is operated through DeviceNet. Identically, when Control Mode 2 is active, the value contained in [G4.1.2] parameter determines the way it is finally controlled.	2	NETDECIDES	The PLC will decide how the drive is controlled. If it is controlled over network, option 1 will be enabled. However, if the net resigns control, it will be controlled locally.	NO		
OPT	DESCRIPTION	FUNCTION																
0	LOCAL	The drive control is given in [G4.1.1] or [G4.1.2] parameter																
1	NET	If the Control Mode 1 parameter [G4.1.1] is active and set to 3 (Comm.), then the drive is operated through DeviceNet. Identically, when Control Mode 2 is active, the value contained in [G4.1.2] parameter determines the way it is finally controlled.																
2	NETDECIDES	The PLC will decide how the drive is controlled. If it is controlled over network, option 1 will be enabled. However, if the net resigns control, it will be controlled locally.																
4 REFEREN MODE=0	G20.4.4 / Reference modes	0 to 2	<p>The following table shows the different reference modes.</p> <table border="1"> <thead> <tr> <th>OPT.</th> <th>FUNCTION</th> </tr> </thead> <tbody> <tr> <td>0</td> <td>LOCAL</td> </tr> <tr> <td>1</td> <td>NET</td> </tr> <tr> <td>2</td> <td>NETDECIDES</td> </tr> </tbody> </table>	OPT.	FUNCTION	0	LOCAL	1	NET	2	NETDECIDES	NO						
OPT.	FUNCTION																	
0	LOCAL																	
1	NET																	
2	NETDECIDES																	
5 FAULT MODE=2	G20.4.5 / Fault Mode	0 – 2	<p>It is used to select what has to do the drive in case of communication fault:</p> <table border="1"> <thead> <tr> <th>OPT</th> <th>FUNCTION</th> </tr> </thead> <tbody> <tr> <td>FAULT</td> <td>Drive trips by fault F60.</td> </tr> <tr> <td>IGNORE</td> <td>The drive keeps operating despite communication loss.</td> </tr> <tr> <td>PE BEHV</td> <td>While the communication wire is not well connected, the drive still tripping.</td> </tr> </tbody> </table>	OPT	FUNCTION	FAULT	Drive trips by fault F60.	IGNORE	The drive keeps operating despite communication loss.	PE BEHV	While the communication wire is not well connected, the drive still tripping.	YES						
OPT	FUNCTION																	
FAULT	Drive trips by fault F60.																	
IGNORE	The drive keeps operating despite communication loss.																	
PE BEHV	While the communication wire is not well connected, the drive still tripping.																	
6 ASM- IN = 70	G20.4.6 / Input assembly	70 71 100 150 151 152	<p>It is used to select, which input instance of the assembly object is to be used for the default data production of IO connection.</p> <table border="1"> <thead> <tr> <th>OPT</th> <th>FUNCTION</th> </tr> </thead> <tbody> <tr> <td>70</td> <td>Basic Speed Status</td> </tr> <tr> <td>71</td> <td>Extended Speed Status</td> </tr> <tr> <td>100</td> <td>Power Electronics Basic Status</td> </tr> <tr> <td>150</td> <td>Power Electronics Extended Status</td> </tr> <tr> <td>151</td> <td>Power Electronics medium status</td> </tr> <tr> <td>152</td> <td>Power Electronics customized status. The two first bytes are status bytes and the next nine registers are selectable. Configurable in parameters SV20.6.1 to SV20.6.9.</td> </tr> </tbody> </table>	OPT	FUNCTION	70	Basic Speed Status	71	Extended Speed Status	100	Power Electronics Basic Status	150	Power Electronics Extended Status	151	Power Electronics medium status	152	Power Electronics customized status. The two first bytes are status bytes and the next nine registers are selectable. Configurable in parameters SV20.6.1 to SV20.6.9.	YES
OPT	FUNCTION																	
70	Basic Speed Status																	
71	Extended Speed Status																	
100	Power Electronics Basic Status																	
150	Power Electronics Extended Status																	
151	Power Electronics medium status																	
152	Power Electronics customized status. The two first bytes are status bytes and the next nine registers are selectable. Configurable in parameters SV20.6.1 to SV20.6.9.																	
7 ASM- OUT=20	G20.4.7 / Output assembly	20 21 101	<p>It is used to select, which output instance of the assembly object is to be used for the default data consumption of the IO connection</p> <table border="1"> <thead> <tr> <th>OPT</th> <th>FUNCTION</th> </tr> </thead> <tbody> <tr> <td>20</td> <td>Basic Speed Control</td> </tr> <tr> <td>21</td> <td>Extended Speed Control</td> </tr> <tr> <td>101</td> <td>Power Electronics Basic Control</td> </tr> </tbody> </table>	OPT	FUNCTION	20	Basic Speed Control	21	Extended Speed Control	101	Power Electronics Basic Control	YES						
OPT	FUNCTION																	
20	Basic Speed Control																	
21	Extended Speed Control																	
101	Power Electronics Basic Control																	
8 DNst = 0	G20.4.8 / DeviceNet State	0 a 4(Read only)	<p>It is a read-only parameter, which value indicates the current state of DeviceNet communications.</p> <table border="1"> <thead> <tr> <th>OPT</th> <th>DESCRIPTION</th> </tr> </thead> <tbody> <tr> <td>0</td> <td>Not used</td> </tr> <tr> <td>1</td> <td>Does not exist</td> </tr> <tr> <td>2</td> <td>MAC ID Duplicated</td> </tr> <tr> <td>3</td> <td>Online</td> </tr> <tr> <td>4</td> <td>Communications Fault</td> </tr> </tbody> </table> <p>On a switch on, the drive automatically enters into the MAC_ID_Duplicated check state. After the successful response to the duplicated MAC ID request messages (2 messages), the drive will enter into the Online state. There, the drive is ready to communicate within DeviceNet network by mean of explicit and I/O messages.</p> <p>If the drive receives any duplicate MAC ID response message, while in Online state, it will switch over to Communications_Fault state. The drive will recover from this communication-faulted state by means of the offline connection set mechanism.</p> <p>The SD700 DeviceNet stack can communicate with the other DeviceNet node which is present in the DeviceNet network through explicit or cyclic I/O messages.</p>	OPT	DESCRIPTION	0	Not used	1	Does not exist	2	MAC ID Duplicated	3	Online	4	Communications Fault	YES		
OPT	DESCRIPTION																	
0	Not used																	
1	Does not exist																	
2	MAC ID Duplicated																	
3	Online																	
4	Communications Fault																	

(*) **Note:** Available if G20.0.1 = 5 DeviceNet

4.20.6. Subgroup 20.5 – S20.5: OFC(*)

Parameter / Default Value	Name / Description	Range	Function	Set on RUN										
1 B/R F.O =1 Mbps	G20.5.1 / Bus speed connected to drive	0 to 3	Choose this parameters according to bus speed: <table border="1"> <thead> <tr> <th>OPTIONS</th> <th>DESCRIPTION</th> </tr> </thead> <tbody> <tr> <td>0</td> <td>125 Kbps</td> </tr> <tr> <td>1</td> <td>250 Kbps</td> </tr> <tr> <td>2</td> <td>500 Kbps</td> </tr> <tr> <td>3</td> <td>1 Mbps</td> </tr> </tbody> </table>	OPTIONS	DESCRIPTION	0	125 Kbps	1	250 Kbps	2	500 Kbps	3	1 Mbps	YES
OPTIONS	DESCRIPTION													
0	125 Kbps													
1	250 Kbps													
2	500 Kbps													
3	1 Mbps													

(*) **Note:** Available if G20.0.1 = 6 OFC

4.20.7. Subgroup 20.6 – S20.6: Registers

Parameter / Default Value	Name / Description	Range	Function	Set on RUN
01 Reg01 = 40001	G20.6.1 / Register 1	40001 to 45400	It allows the user to have the modbus address that he wants in each register. In this way he will have consecutive Modbus addresses that are interesting for him and in this way the communication will be optimal.	YES
02 Reg02 = 40001	G20.6.2 / Register 2			
03 Reg03 = 40001	G20.6.3 / Register 3			
04 Reg04= 40001	G20.6.4 / Register 4			
.....			
31 Reg31 = 40001	G20.6.31 / Register 31			

4.20.8. Subgroup 20.7 – S20.7: Vis Regist

Parameter / Default Value	Name / Description	Range	Function	Set on RUN
01 Reg01 = 0	G20.7.1 / Register 1	0 to 65535	It allows the user to view and write (if the parameter is writing allowed) the values of the configured addresses in the subgroup 'G20.6 Registers'.	YES
02 Reg02 = 0	G20.7.2 / Register 2			
03 Reg03 = 0	G20.7.3 / Register 3			
04 Reg04= 0	G20.7.4 / Register 4			
.....			
31 Reg31 = 0	G20.7.31 / Register 31			

4.21. Group 21 – G21: Networks

This parameter group is used to configure the drive when it should operate in Ethernet network.

Note: This parameter group and its corresponding subgroups will be only available when the Ethernet board is connected to the drive.

4.21.1. Subgroup 21.1 – S21.1: ETHERNET

This parameter subgroup is used to configure the identification parameters of the drive in the Ethernet network (IP, Subnet Mask, Gateway), and the MAC address.

Parameter / Default Value	Name / Description	Range	Function	Set on RUN						
1 AUTOMATIC IP=Y	G21.1.1 / To enable automatic assignation of parameters	N Y	It allows the possibility of assigning the parameters automatically. <table border="1"> <thead> <tr> <th>OPT.</th> <th>FUNCTION</th> </tr> </thead> <tbody> <tr> <td>N=NO</td> <td>The drive will take IP, Subnet Mask and Gateway addresses set by user from subgroup S21.1.</td> </tr> <tr> <td>Y=YES</td> <td>The drive request and receives the parameters of the IP, Subnet Mask and Gateway addresses from the Network Server. To achieve this, it is used DHCP protocol.</td> </tr> </tbody> </table>	OPT.	FUNCTION	N=NO	The drive will take IP, Subnet Mask and Gateway addresses set by user from subgroup S21.1.	Y=YES	The drive request and receives the parameters of the IP, Subnet Mask and Gateway addresses from the Network Server. To achieve this, it is used DHCP protocol.	YES
OPT.	FUNCTION									
N=NO	The drive will take IP, Subnet Mask and Gateway addresses set by user from subgroup S21.1.									
Y=YES	The drive request and receives the parameters of the IP, Subnet Mask and Gateway addresses from the Network Server. To achieve this, it is used DHCP protocol.									
lxxx.yyy.zzz.hhh	Present IP address of the drive	-	It shows the IP address assigned to the drive automatically or set by the user from the parameters G21.1.2, G21.1.3, G21.1.4 and G21.1.5.	-						
Sxxx.yyy.zzz.hhh	Present Subnet Mask of the drive	-	It shows the Subnet Mask address assigned to the drive automatically or set by the user from parameters G21.1.6, G21.1.7, G21.1.8 and G21.1.9.	-						

Parameter / Default Value	Name / Description	Range	Function	Set on RUN
Gxxx.yyy.zzz.hhh	Present Gateway of the drive	-	It shows the Gateway address assigned to the drive automatically or set by the user from parameters G21.1.10, G21.1.11, G21.1.12 and G21.1.13.	-
2 IP MANU. A=192 ^[6]	G21.1.2 / IP address (A)	0 to 255	<p>Setting of the IP address assigned to the equipment in the local network of the user. This address must be provided by the network administrator of the own user.</p> <p>The format of the IP address is the following one: A.B.C.D. Therefore, the setting of this address is realized by introducing a value in each parameter that configures the complete address, this is, by assigning a value to each one of the 4 parameters (from parameter G21.1.2 to the parameter G21.1.5).</p> <p>Setting of the Subnet Mask address of the local network of the user. This address must be provided by the network administrator of the own user.</p> <p>The format of the Subnet Mask address is the following one: A.B.C.D. Therefore, the setting of this address is realized by introducing a value in each parameter that configures the complete address, this is, by assigning a value to each one of the 4 parameters (from parameter G21.1.6 to the parameter G21.1.9).</p>	YES
3 IP MANU. B=168 ^[6]	G21.1.3 / IP address (B)	0 to 255		YES
4 IP MANU. C=1 ^[6]	G21.1.4 / IP address (C)	0 to 255		YES
5 IP MANU. D=143 ^[6]	G21.1.5 / IP address (D)	0 to 255		YES
6 SUBNET A=255 ^[6]	G21.1.6 / Subnet Mask address (A)	0 to 255		YES
7 SUBNET B=255 ^[6]	G21.1.7 / Subnet Mask address (B)	0 to 255		YES
8 SUBNET C=255 ^[6]	G21.1.8 / Subnet Mask address (C)	0 to 255		YES
9 SUBNET D=0 ^[6]	G21.1.9 / Subnet Mask address (D)	0 to 255		YES
10 GATEWAY A=0 ^[6]	G21.1.10 / Gateway address (A)	0 to 255		YES
11 GATEWAY B=0 ^[6]	G21.1.11 / Gateway address (B)	0 to 255		YES
12 GATEWAY C=0 ^[6]	G21.1.12 / Gateway address (C)	0 to 255		YES
13 GATEWAY D=0 ^[6]	G21.1.13 / Gateway address (D)	0 to 255		YES
14 MAC A=0	G21.1.14 / MAC address (A)	0 to 255		YES
15 MAC B=80	G21.1.15 / MAC address (B)	0 to 255		YES
16 MAC C=194	G21.1.16 / MAC address (C)	0 to 255		YES
17 MAC D=114	G21.1.17 / MAC address (D)	0 to 255		YES
18 MAC E=X	G21.1.18 / MAC address (E)	0 to 255		YES
19 MAC F=Y	G21.1.19 / MAC address (F)	0 to 255		YES

^[6] These parameters will be only available if 'G21.1.1 AUTOMATIC IP = N'.

4.21.2. Subgroup 21.2 – S21.2: MODBUS TCP

Parameter / Default Value	Name / Description	Range	Function	Set on RUN
1 MIPtout=OFF MODBUS TCP TOUT	G21.2.1 / Communication timeout MODBUS TCP	OFF=0 to 600s	<p>When the equipment is powered, if this parameter is set to OFF (this means, set to some value), the drive will wait for the first communication frame during one minute without considering the set value. If during this minute a Modbus request is produced by the Master, the equipment will respond, and from this moment on, the time without communication will be the value set in this parameter, but if during the first minute the equipment does not receive any correct Modbus frame, the drive will trip because of communication fault.</p> <p>Note: Do not modify the value of this parameter if it is not necessary.</p>	YES

4.21.3. Subgroup 21.3 – S21.3: ETHER/IP

Parameter / Default Value	Name / Description	Range	Function	Set on RUN												
1 CONTROL MODE=0	G21.3.1 / Control mode of the drive	0 – 2	<p>This parameter allows setting how the drive will be controlled.</p> <table border="1"> <thead> <tr> <th>OPT.</th> <th>DESCRIPTION</th> <th>FUNCTION</th> </tr> </thead> <tbody> <tr> <td>0</td> <td>LOCAL</td> <td>The drive can be started and stopped like the equipment is not connected to the Ethernet network, this means, from the settings in G4.1.1 or G4.1.2.</td> </tr> <tr> <td>1</td> <td>NETWORK</td> <td>The drive can only be controlled through the Ethernet/IP Client by means of the Ethernet board. In this case, the setting of G4.1.1 and G4.1.2 is ignored.</td> </tr> <tr> <td>2</td> <td>NET DECIDES</td> <td>In this case, the Ethernet/IP Client, through the Ethernet board, will inform the drive all the time about who is controlling it.</td> </tr> </tbody> </table>	OPT.	DESCRIPTION	FUNCTION	0	LOCAL	The drive can be started and stopped like the equipment is not connected to the Ethernet network, this means, from the settings in G4.1.1 or G4.1.2.	1	NETWORK	The drive can only be controlled through the Ethernet/IP Client by means of the Ethernet board. In this case, the setting of G4.1.1 and G4.1.2 is ignored.	2	NET DECIDES	In this case, the Ethernet/IP Client, through the Ethernet board, will inform the drive all the time about who is controlling it.	NO
OPT.	DESCRIPTION	FUNCTION														
0	LOCAL	The drive can be started and stopped like the equipment is not connected to the Ethernet network, this means, from the settings in G4.1.1 or G4.1.2.														
1	NETWORK	The drive can only be controlled through the Ethernet/IP Client by means of the Ethernet board. In this case, the setting of G4.1.1 and G4.1.2 is ignored.														
2	NET DECIDES	In this case, the Ethernet/IP Client, through the Ethernet board, will inform the drive all the time about who is controlling it.														
2 REFEREN.MODE=0	G21.3.2 / Reference mode of the drive	0 – 2	<p>This parameter allows setting from where the speed reference is provided to the drive.</p> <table border="1"> <thead> <tr> <th>OPT.</th> <th>DESCRIPTION</th> <th>FUNCTION</th> </tr> </thead> <tbody> <tr> <td>0</td> <td>LOCAL</td> <td>The drive will take the reference from parameters G3.1 or G3.2.</td> </tr> <tr> <td>1</td> <td>NETWORK</td> <td>The reference will only be taken through the Ethernet/IP Client by means of the Ethernet board. In this case, the setting of G3.1 and G3.2 is ignored.</td> </tr> <tr> <td>2</td> <td>NET DECIDES</td> <td>In this case, the Ethernet/IP Client, through the Ethernet board, will inform the drive all the time about who is providing the speed reference to it.</td> </tr> </tbody> </table>	OPT.	DESCRIPTION	FUNCTION	0	LOCAL	The drive will take the reference from parameters G3.1 or G3.2.	1	NETWORK	The reference will only be taken through the Ethernet/IP Client by means of the Ethernet board. In this case, the setting of G3.1 and G3.2 is ignored.	2	NET DECIDES	In this case, the Ethernet/IP Client, through the Ethernet board, will inform the drive all the time about who is providing the speed reference to it.	NO
OPT.	DESCRIPTION	FUNCTION														
0	LOCAL	The drive will take the reference from parameters G3.1 or G3.2.														
1	NETWORK	The reference will only be taken through the Ethernet/IP Client by means of the Ethernet board. In this case, the setting of G3.1 and G3.2 is ignored.														
2	NET DECIDES	In this case, the Ethernet/IP Client, through the Ethernet board, will inform the drive all the time about who is providing the speed reference to it.														
3 FAULT MODE = 2	G21.3.3 / Fault Mode	0 – 2	<p>It is used to select what has to do the drive in case of communication fault:</p> <table border="1"> <thead> <tr> <th>OPT</th> <th>FUNCTION</th> </tr> </thead> <tbody> <tr> <td>FAULT</td> <td>Drive trips by fault F60.</td> </tr> <tr> <td>IGNORE</td> <td>The drive keeps operating despite communication loss.</td> </tr> <tr> <td>PE BEHV</td> <td>While the communication wire is not well connected, the drive still tripping.</td> </tr> </tbody> </table>	OPT	FUNCTION	FAULT	Drive trips by fault F60.	IGNORE	The drive keeps operating despite communication loss.	PE BEHV	While the communication wire is not well connected, the drive still tripping.	YES				
OPT	FUNCTION															
FAULT	Drive trips by fault F60.															
IGNORE	The drive keeps operating despite communication loss.															
PE BEHV	While the communication wire is not well connected, the drive still tripping.															

5. MODBUS COMMUNICATION

5.1. Supported Modbus Function Codes

Serial communications protocol provided by SD700 drive adheres to Modbus Industrial standard communications protocol of Modicon. The drive uses reading and writing functions between all of the functions that exist in Modbus protocol. The used functions by the drive are the following ones:

Function	Description	Registers Number
3	Registers Reading	120
16	Registers Writing	120

The implementation of this function code in the drive allows reading up to 120 registers into a Parameters Group in a frame. If you want to access to a consecutive memory registers, but belonging to different groups, you should access in so many frames as groups are involved.

5.1.1. Modbus Function Code N° 3: Registers Reading

This function code allows the Modbus controller (master) to read the content of the data registers indicated in the drive (slave). This function code only admits unicast addressing. Broadcast or groupcast addressing are not possible with this function code.

The implementation of this function code in the drive allows reading up to 120 registers with consecutive addresses of the drive in a single frame.

Next, a frame is shown where the master tries to read the content of 3 registers of a drive where the current used by each phase is. The information that should be attached in the ask frame is the following one:

- Data address of the drive.
- Modbus function code (3 Registers reading).
- Starting Data address.
- Registers number for reading.
- CRC-16 code.

The answer of the drive (slave) should contain the following fields:

- Data address of the slave.
- Modbus function code (3 Registers reading).
- Bytes number for reading.
- Bytes number / 2 registers.
- CRC-16 code.

Each register consists of 2 bytes (2x8bits=16 bits). This one is the default length of all of the registers that form the SD700.

5.1.1.1. Operation Example of Modbus Function Code N° 3 (Registers Reading)

We suppose that we want to read the motor current (nameplate data) via communications. This data corresponds to the parameter G2.1 '1 MTR CUR=00.00A'. The frame that should be transmitted is:

Modbus Address	Modbus Function Code	Starting Data Address (40282)	Registers Number	CRC-16
0x0A	0x03	0x0119	0x0001	0x2493

We suppose that instantaneous current of the equipment is 8,2 A. (Modbus value 82 decimal = 0x52 Hexadecimal). The answer of the slave will be:

Modbus Address	Modbus Function Code	Bytes Number	Data (address 20) (=110)	CRC-16
0x0A	0x03	0x02	0x0052	0x9C78

5.1.2. Modbus Function Code N° 16: Registers Writing

This function code allows the Modbus controller (master) to write the content of the data registers indicated in the drive (slave), whenever those registers are not of Read only. Registers writing by the master does not impede the later modification of those registers by the slave.

The implementation of this function code in the drive allows writing up to 5 registers of the drive in a single frame.

Next, a frame is shown where the master tries to write the content of 1 register that stores the acceleration time. The information that should be attached in the ask frame is the following one:

- Data address of the slave.
- Modbus function code (16 Registers writing).
- Starting Data Address.
- Registers number for writing.
- Bytes number for writing.
- Content of registers for writing.
- CRC-16 code.

The answer of the slaves includes:

- Data address of the slave.
- Modbus function code (16 Registers writing).
- Starting Data Address.
- Written registers number.
- CRC-16 code.

5.2. Addressing Modes

5.2.1. Broadcast Addressing Mode

Broadcast addressing mode allows the master to access at the same time to all of the slaves connected to the Modbus network. The Modbus function code that admits this global addressing mode is:

Function	Description
16	Registers Writing

In order to access to all of the equipments connected in a Modbus network, you must use the address 0.

When this address is used, all of the slaves in the Modbus network make the required task but they do not prepare any answer.

5.3. Remote Control Functions

HOST START CONTROL

Screen	-
Range	0 – 1
Modbus address	40562
Modbus range	0 to 1
Read / Write	YES
Description	It allows giving the start command to the equipment through communications network.

HOST STOP CONTROL

Screen	-
Range	0 – 1
Modbus address	40563
Modbus range	0 to 1
Read / Write	YES
Description	It allows giving the stop command to the equipment through communications network.

HOST RESET CONTROL

Screen	-
Range	0 – 1
Modbus address	40564
Modbus range	0 to 1
Read / Write	YES
Description	It allows giving the reset command to the equipment through communications network.

HOST TRIP CONTROL

Screen	-
Range	0 – 1
Modbus address	40565
Modbus range	0 to 1
Read / Write	YES
Description	It allows the equipment to generate a fault through communications network.

HOST COMMS CONTROL

Screen	-
Range	-20480 to +20480
Modbus address	40128
Modbus range	-20480 to +20480
Read / Write	YES
Description	It allows the assignment of the speed reference through communications network.

5.4. Summary of Modbus Addresses

5.4.1. Modbus Register 'GENERAL STATUS'

This register supplies information about the general status of the drive, as the following table shows:

Modbus Address	Bit	Description	Meaning on '0'	Meaning on '1'
40558	0	RUN	Drive stopped	Drive running
	1	FAULT	No Fault	Fault
	2	WARNING	No Warning	At least one warning present
	3	READY	The drive is not ready to start (any fault or warning is present)	The drive is ready to start (no fault and no warning)
	4	EXTERNAL POWER SUPPLY	The drive is powered through internal power supply	The drive is powered through external power supply
	5	DELAYING START	Not delaying start	Delaying start
	6	MOTOR OVERLOAD	Motor overload warning (MOL) is not active	Motor overload warning (MOL) is active
	7	MOTOR OVERLOAD FAULT	Motor overload fault (F25) is not present	Motor overload fault (F25) is present
	8	RESERVED	Reserved	Reserved
	9	DRIVE AT SET SPEED	Motor speed is different to the reference speed	Motor speed has reached the value set as reference
	10	CURRENT LIMIT	Current limitation warning (ILT) is not present	Current limitation warning (ILT) is present
	11	VOLTAGE LIMIT	Voltage limitation warning (VLT) is not present	Voltage limitation warning (VLT) is present
	12	TORQUE LIMIT	Torque limitation warning (TLT) is not present	Torque limitation warning (TLT) is present
	13	COMPARATOR 1	Comparator 1 is 'OFF'	Comparator 1 is 'ON'
	14	COMPARATOR 2	Comparator 2 is 'OFF'	Comparator 2 is 'ON'
15	COMPARATOR 3	Comparator 3 is 'OFF'	Comparator 3 is 'ON'	

5.4.2. Programming Parameters

Parameter	Screen	Description	Address	Range	Modbus Range
G1.1	1 LOCK PARMTRS=0	Parameter lock	-	0 to 2	-
G1.2	2 PASSWORD=OFF	Access password	-	OFF, 0000 to 9999	-
G1.3	3 PSW ERR=XXXX	Unlock password recovery	-	0000 to 9999	-
G1.4	4 LANGUA=ESPAÑOL	Language selection	-	ENGLISH ESPAÑOL DEUTSCH PORTUGUE	-
G1.5	5 INITIALISE=0	Parameter initialize	-	0 to 5	-
G1.6	6 SHORTmenu=NO	To hide some configuration menus	-	NO YES	-
G1.7	7 PROG= STANDAR	Program activation	-	STANDARD PUMP	-
G1.8	SV1.8 Visual				
G1.11	11 FAN CTRL=FIXE	Drive fan control mode	40549	RUN TEMP FIX	0 to 2
G.1.10.1	1 UPLOAD=N	Save parameters from drive to display.		NO YES	0 to 1
G1.10.2	2 DOWNLOAD=N	Save parameters from drive to display.		NO YES	0-1
G1.12	12 RECT.BRIDGE=0	Amount of pulses of the rectifier bridge	40580	0 to 3	0 to 3
G1.14	14 SER GRP PWD = OFF	Group reserved for the Technical Service			
G2.1	1 MTR CUR=A	Motor rated current	40282	1 to 9999A	1638 to 12288
G2.2	2 MTR VOLT=400V	Motor rated voltage	40283	220 to 999V	220 to 999
G2.3	3 MTR PWR=Kw	Motor rated power	40285	0 to 6500kW	0 to 65000
G2.4	4 MTR RPM=1485	Motor rpm	40286	0 to 24000 rpm	0 to 24000
G2.5	5 MTR PFA=0.85	Cosine Phi	40288	0 to 0.99	0 to 99
G2.6	6 MTR FRQ=50Hz	Motor rated frequency	40284	0 to 100Hz	0 to 100
G2.7	7 MTR COOLN=63%	Motor cooling at zero speed	40287	OFF; 5 to 100%	8274;410 to 8192
G3.1	1 REF1 SPD=LOCAL	Reference source 1 of speed	40122	NONE AI1 AI2 AI1+AI2 FIB_1 LOCAL MREF PMOT PID COMMS FIB_2	0 to 11
G3.2	2 REF2 SPD=LOCAL	Reference source 2 of speed	40123	NONE AI1 AI2 AI1+AI2 FIB_1 LOCAL MREF PMOT PID COMMS FIB_2	0 to 11
G3.3	3 LOCAL SP=+100%	Local Speed Reference	40124	-250 to +250%	-20480 to + 20480
G3.4	4 REF1 TQ = LOCAL	Torque reference supply 1	40125	NONE AI1 AI2 AI1+AI2 FIB_1 LOCAL MREF PID COMMS FIB_2	0 to 11

Parameter	Screen	Description	Address	Range	Modbus Range
G3.5	5 REF2 TQ = LOCAL	Torque reference supply 2	40126	NONE AI1 AI2 AI1+AI2 FIB_1 LOCAL MREF PID COMMS FIB_2	0 to 11
G3.6	6 TQ = +100%	Torque local reference	40127	-250 to +250%	-20480 to +20480
G4.1.1	1 CNTR0L MODE1=1	Main Control Mode	40040	0 to 4	0 to 4
G4.1.2	2 CNTR0L MODE2=2	Alternative Control Mode	40041	0 to 4	0 to 4
G4.1.3	3 RESE0T MODE=Y	Reset from keypad	40039	N Y	0 to 1
G4.1.4	4 DIGIT I MODE=1	Selection of Digital Inputs configuration	40038	0 to 5	0 to 5
G4.1.5	5 DIGITL IN 1=06	Multi-function Digital Input 1 configuration	40032	00 to 75	0 to 75
G4.1.6	6 DIGITL IN 2=00	Multi-function Digital Input 2 configuration	40033	00 to 75	0 to 75
G4.1.7	7 DIGITL IN 3=00	Multi-function Digital Input 3 configuration	40034	00 to 75	0 to 75
G4.1.8	8 DIGITL IN 4=00	Multi-function Digital Input 4 configuration	40035	00 to 75	0 to 75
G4.1.9	9 DIGITL IN 5=00	Multi-function Digital Input 5 configuration	40036	00 to 75	0 to 75
G4.1.10	10 DIGITL IN6=17	Multi-function Digital Input 6 configuration	40037	00 to 75	0 to 75
G4.2.1	1 SENSOR 1 ?=N	To enable sensor of Analogue Input 1	40268	N Y	0 to 1
G4.2.2	2 SENSOR 1=I/s	Selection of sensor 1 units	40272	% I/s m ³ /s I/m m ³ /m I/h m ³ /h m/s m/m m/h Bar kPa Psi m °C °F °K Hz rpm	0 to 18
G4.2.3	3 AIN1 FORMAT=V	Analogue Input 1 format	40264	V mA	0 to 1
G4.2.4	4 Inmin1=+0V	Minimum range of Analogue Input 1	40248	-10V to G4.2.6 +0mA to G4.2.6	-10000 to +10000 0 to +20000
G4.2.5	5 Smi1=+0.0I/s	Minimum range of sensor 1	40254	-3200 to G4.2.7 Engineering Units	-32000 to +32000
G4.2.6	6 Inmax1=+10V	Maximum range of Analogue Input 1	40244	G4.2.4 to +10V G4.2.4 to +20mA	-10000 to +10000 0 to +20000
G4.2.7	7 Sma1=+10.0I/s	Maximum range of sensor 1	40250	G4.2.5 to +3200 Engineering Units	-32000 to +32000
G4.2.8	8 SPD LO1=+0%	Speed for the minimum range of Analogue Input 1	40246	-250% to G4.2.9	-20480 to +20480
G4.2.9	9 SPD HI1=+100%	Speed for the maximum range Analogue Input 1	40242	G4.2.8 to +250%	-20480 to +20480
G4.2.10	10 FB1 = +0.0I/s	Minimum operating range of sensor	40256	-3200 to G4.2.12 Engineering Units	-32000 to +32000
G4.2.11	11 FB1-SP = 0%	Minimum speed range for sensor in open loop	40260	-250% to +250%	-20480 to 20480
G4.2.12	12 FA1 = +10.0I/s	Maximum operating range of sensor	40252	G4.2.10 to +3200 Engineering Units	-32000 to +32000
G4.2.13	13 FA1-SP = 100%	Maximum speed range for sensor in open loop	40258	-250% to +250%	-250% to +250%
G4.2.14	14 AIN1 LOSS=N	Protection for Analogue Input 1 loss	40266	N Y	0 to 1
G4.2.15	15 1_Z BAND=OFF	Zero band filter for Analogue Input 1	40270	OFF = 0.0; 0.1 to 2.0%	9 to 163
G4.2.16	16 FILTER1=OFF	Low Pass filter for Analogue Input 1	40274	OFF = 0.0; 0.1 to 20.0%	0 to 200

Parameter	Screen	Description	Address	Range	Modbus Range
G4.3.1	1 SENSOR 2 ?=N	Sensor of Analogue Input 2 enable	40269	N Y	0 to 1
G4.3.2	2 SENSOR 2=Bar	Selection of sensor 2 units	40273	% l/s m ³ /s l/m m ³ /m l/h m ³ /h m/s m/m m/h Bar kPa Psi m °C °F °K Hz rpm	0 to 18
G4.3.3	3 AIN2 FORMAT=mA	Analogue Input 2 format	40265	V mA	0 to 1
G4.3.4	4 Inmin2=+4mA	Minimum range of Analogue Input 2	40249	-10V to G4.3.6 +0mA to G4.3.6	-10000 to +10000 0 to +20000
G4.3.5	5 Smi2=+0.0Bar	Minimum range of sensor 2	40255	-3200 to G4.3.7 Engineering Units	-32000 to +32000
G4.3.6	6 Inmax2=+20mA	Maximum range of Analogue Input 2	40245	G4.3.4 to +10V G4.3.4 to +20mA	-10000 to +10000 0 to +20000
G4.3.7	7 Sma2=+10.0Bar	Maximum range of sensor 2	40251	G4.3.5 to +3200 Engineering Units	32000 to +32000
G4.3.8	8 SPD LO2=+0%	Speed for the minimum range of Analogue Input 2	40247	-250% to G.4.3.9	-20480 to +20480
G4.3.9	9 SPD HI2=+100%	Speed for the maximum range of Analogue Input 2	40243	G4.3.8 to +250%	-20480 to +20480
G4.3.10	10 FB2 = +0.0Bar	Minimum operating range of sensor	40257	-3200 to G4.3.12 Engineering Units	-32000 to +32000
G4.3.11	11 FB2-SP = 0%	Minimum speed range for sensor in open loop	40261	-250% to +250%	-250 to +250
G4.3.12	12 FA2 = +10.0Bar	Maximum operating range of sensor	40253	G4.3.10 to +3200 Engineering Units	-32000 to +32000
G4.3.13	13 FA2-SP = 100%	Maximum speed range for sensor in open loop	40259	-250% to +250%	-250 to +250
G4.3.14	14 AIN2 LOSS=N	Protection for Analogue Input 2 loss	40267	N Y	0 to 1
G4.3.15	15 2_Z BAND=OFF	Zero band filter for Analogue Input 2	40271	OFF=0.0; 0.1 to 2.0%	9 to 163
G4.3.16	16 FILTER2=OFF	Low Pass filter for Analogue Input 2	40275	OFF = 0.0; 0.1 to 20.0%	0 to 200
G4.4.1	1 Sensr U=l/s	Sensor units of Pulse Input	40581	% l/s m ³ /s l/m m ³ /m l/h m ³ /h m/s m/m m/h	0 to 9
G4.4.2	2 Pls/s = 100l/s	Flowmeter configuration	40582	0 to 32760 Flow Units	0 to 32760
G4.4.3	3 M Rn=1000l/s	Maximum range of flow meter	40583	0 to 32760 Flow Units	0 to 32760
G4.6.1	1 FIBER MODE = 0	Fiber Mode	41251	MAS SLV NON	0 to 2
G4.6.3.5	5 CONTROL = NONE	Control	41254	NONE START RUN	0 to 2
G4.6.3.6	6 FAULT = N	Control (Master)	41255	N Y	0 to 1
G4.6.3.7	7 SPIN STP = N	SPIN STOP (Slave)	41256	N Y	0 to 1
G4.6.5	5 T/O F.O = 0	Time out optical fiber (Slave)	41253	OFF, 0.10 to 9.99	0 to 10
G5.1	1 ACC1=5.0%/s	Acceleration ramp 1	40392	0.01 to 650% / sec	1 to 65000
G5.2	2 DECEL1=1.0%/s	Deceleration ramp 1	40394	0.01 to 650% / sec	1 to 65000

Parameter	Screen	Description	Address	Range	Modbus Range
G5.3	3 ACC2=10.0%/s	Acceleration ramp 2	40393	0.01 to 650% / sec	1 to 65000
G5.4	4 DECEL2=10.0%/s	Deceleration ramp 2	40395	0.01 to 650% / sec	1 to 65000
G5.5	5 BRK ACC=OFF	Speed for acceleration ramp change	40396	OFF; 0 to 250%	0 to 20480
G5.6	6 BRK DEC=OFF	Speed for deceleration ramp change	40397	OFF; 0 to 250%	0 to 20480
G5.7	7 MPT INC1=1.0%/s	Ramp 1 of reference increase for motorized pot.	40400	0.01 to 650% / sec	10 to 65000
G5.8	8 MPT DEC1=3.0%/s	Ramp 1 of reference decrease for motorized pot.	40399	0.01 to 650% / sec	10 to 65000
G5.9	9 MPT INC2=1.0%/s	Ramp 2 of reference increase for motorized potentiometer	40398	0.01 to 650% / sec	10 to 65000
G5.10	10 MPT DEC2=3.0%/s	Ramp 2 of reference decrease for motorized potentiometer	40401	0.01 to 650% / sec	10 to 65000
G5.11	11 MPOT BRK = OFF	Speed for ramp change with motorized pot.	40402	OFF=0 to 250%	0 to 20480
G5.12	12 SP FLT=0.250s	Time constant to filter the speed	40403	OFF, 0.0 to 80.0%	0 to 60000
G6.1	1 SEL REF=MREF	Source selection for introducing reference signal	40142	NONE AI1 AI2 RESERV MREF LOCAL locPID COMMS	0 to 8
G6.2	2 PID LOC=+100%	PID local reference	40149	+0.0% to +400%	0 to 32760
G6.3	3 SEL FBK=AI2	Selection of feedback signal source	40143	NONE AI1 AI2 AI1+AI2 COMMS MtrTrq AbsMTq Mtr I. MtrPwr BUSVdc PhiCos	0 to 11
G6.4	4 GAIN Kp=8.0	Proportional gain of PID control	40144	0.1 to 20	1 to 200
G6.5	5 INTEGRAL = 0.0s	Integration time of PID control	40145	0.0 to 1000s; Max	0 to 10000; 10001
G6.6	6 DIFFEREN = 0.0s	Derivation time of PID control	40146	0.0 to 250s	0 to 2500
G6.7	7 INVERT PID=N	PID output inversion	40147	N Y	0 to 1
G6.8	8 Filt FB = OFF	Low pass filter	40150	OFF=0 to 20s	0 to 200
G6.9	9 ERR PID = +0.0%	PID control error	40148	-400 to 400%	-32768 to 32767
G7.1	1 STOP 1 = RAMP	Stop mode 1	40003	RAMP SPIN	0 to 1
G7.2	2 STOP 2 = SPIN	Stop mode 2	40004	RAMP SPIN	0 to 1
G7.3	3 BRK STP 2 = OFF	Changing speed for stop mode	40005	OFF=0 to 250%	0 to 20480
G7.4	4 START = RAMP	Start mode	40002	RAMP SPIN SPIN2	0 to 2
G7.5	5 START 2=RAMP	Start mode 2	40015	RAMP SPIN SPIN2	0 to 2
G7.6	6 STAR DLY = OFF	Start delay time	40006	OFF=0 to 6500s	0 to 65000
G7.7	7 STOP DLY = OFF	Stop delay time	40007	OFF=0 to 6500s	0 to 65000
G7.8	8 STP MIN SP = N	Minimum stop speed	40008	N Y	0 to 1
G7.9	9 OFFdly = OFF	Delay time between stop and next start	40014	OFF=0.000 to 10.0s	0 to 10000
G7.10	10 RUN AFTR VFL = N	Run after occurring power loss	40009	N Y	0 to 1
G7.11	11 SPNstr B = OFF	Accuracy setting for Starting by Spin	40017	OFF=0;1 to 10%	0 to 1000
G7.12	12 OFFdly2 = OFF	Delay time for start command after stop	40031	OFF=0; 0.1 to 6500.0s	0 to 65000
G7.13	13 STR AFT RST=N	Starting after fault reset with start command	40010	N Y	0 to 1
G7.14	14 RPWr OFF = OFF	Power Off Delay	41852	OFF, 0.001 to 9.99	0-9990
G7.15	15 MagneT = OFF	Magnetization time	40404	OFF, 0.001 to 9.99	0-9990
G7.16	16 RetATR = OFF	Start Delay after Reset.	41561	OFF, 0.001 to 9.99	0-9990
G8.1.1	1 SEL RELAY 1=02	Selection of Relay 1 control source	40362	00 to 45	0 to 45
G8.1.2	2 T R1 ON=0.0s	ON delay time for Relay 1	40363	0.0 to 999s	0 to 9999
G8.1.3	3 T R1 OFF=0.0s	OFF delay time for Relay 1	40364	0.0 to 999s	0 to 9999
G8.1.4	4 INVERT REL1=N	Relay 1 inversion	40365	N Y	0 to 1

Parameter	Screen	Description	Address	Range	Modbus Range
G8.1.5	5 SEL RELAY 2=03	Selection of Relay 2 control source	40366	00 to 45	0 to 45
G8.1.6	6 T R2 ON=0.0s	ON delay time for Relay 2	40367	0.0 to 999s	0 to 9999
G8.1.7	7 T R2 OFF=0.0s	OFF delay time for Relay 2	40368	0.0 to 999s	0 to 9999
G8.1.8	8 INVERT REL2=N	Relay 2 inversion	40369	N Y	0 to 1
G8.1.9	9 SEL RELAY 3=05	Selection of Relay 3 control source	40370	00 to 45	0 to 45
G8.1.10	10 T R3 ON=0.0s	ON delay time for Relay 3	40371	0.0 to 999s	0 to 9999
G8.1.11	11 T R3 OFF=0.0s	OFF delay time for Relay 3	40372	0.0 to 999s	0 to 9999
G8.1.12	12 INVERT REL3=N	Relay 3 inversion	40373	N Y	0 to 1
G8.1.13	13 CRAspdOF=+5.0%	Speed for disconnecting relay in option Crane	40597	+0.0% to +250%	0 to 20480
G8.1.34	34 Dig Out FB = DO1	Digital Output Feedback	41155	DO1 DO2 DO3	0 to 2
G8.1.35	35 DlyDoFB = 1.0s	Delay Digital Output Feedback	41156	0.5 to 60s	5 to 600
G8.1.36	36 FAULT1 = OFF	Closure of digital output "FAULT1"	41151	0 to 90	0 to 90
G8.1.37	37 FAULT2 = OFF	Closure of digital output "FAULT2"	41152	0 to 90	0 to 90
G8.1.38	38 FAULT3 = OFF	Closure of digital output "FAULT3"	41153	0 to 90	0 to 90
G8.1.39	39 FAULT4 = OFF	Closure of digital output "FAULT4"	41154	0 to 90	0 to 90
G8.2.1	1 ANLG OUT1=01	Mode selection for Analogue Output 1	40342	00 to 27	0 to 27
G8.2.2	2 FORMT 1=4-20 mA	Format selection for Analogue Output 1	40343	0-10V ±10V 0-20mA 4-20mA	0 to 3
G8.2.3	3 MIN1 RNG=+0%	Low of range selection Analogue Output 1	40344	-250% to +250%	-20480 to +20480
G8.2.4	4 MAX1 RNG=+100%	High range selection of Analogue Output 1	40345	-250% to +250%	-20480 to +20480
G8.2.5	5 FILTER 1=OFF	Filter selection for Analogue Output 1	40346	OFF= 0.0 to 20.0s	0 to 200
G8.2.6	6 ANLG OUT 2=02	Mode selection Analogue Output 2	40347	00 to 27	0 to 27
G8.2.7	7 FORMT 2=4-20 mA	Format selection for Analogue Output 2	40348	0-10V ±10V 0-20mA 4-20mA	0 to 3
G8.2.8	8 MIN2 RNG=+0%	Low range selection of Analogue Output 2	40349	-250% to +250%	-20480 to +20480
G8.2.9	9 MAX2 RNG=+100%	High range selection of Analogue Output 2	40350	-250% to +250%	-20480 to +20480
G8.2.10	10 FILTER 2=OFF	Filter selection for Analogue Output 2	40351	OFF=0.0 to 20.0s	0 to 200
G9.1.1	1 COMP 1 SEL=00	Source selection for Comparator 1	40302	00 to 22	0 to 22
G9.1.2	2 COMP 1 TYPE=0	Comparator 1 type selection	40303	0 to 1	0 to 1
G9.1.3	3 SP C1 ON=+100[%]	Activation value of Comparator 1 in Normal mode	40305	-250% to +250%	-20480 to +20480
G9.1.4	4 LIM 2 C1=+100[%]	Limit 2 for Comparator 1 in Window mode	40305	-250% to +250%	-20480 to +20480
G9.1.5	5 LIM 1 C1=+0[%]	Limit 1 for Comparator 1 in Window mode	40304	-250% to +250%	-20480 to +20480
G9.1.6	6 T C1 ON=0.0s	ON delay time for Comparator 1	40306	0.0 to 999s	0 to 9999
G9.1.7	7 SP C1 OF=+0[%]	Deactivation value of Comparator 1 in Normal mode	40304	-250% to +250%	-20480 to +20480
G9.1.8	8 T C1 OF=0.0s	OFF delay time for Comparator 1	40307	0.0 to 9999s	0 to 99999
G9.1.9	9 SEL FUNT C1=00	Selection of output function for Comparator 1	40308	00 to 15	0 to 15
G9.2.1	1 COMP 2 SEL=00	Source selection for Comparator 2	40311	00 to 22	0 to 22
G9.2.2	2 COMP 2 TYPE=0	Comparator 2 type selection	40312	0 to 1	0 to 1
G9.2.3	3 SP C2 ON=+100[%]	Activation value of Comparator 2 in Normal mode	40314	-250% to +250%	-20480 to +20480
G9.2.4	4 LIM 2 C2=+100[%]	Limit 2 for Comparator 2 in Window mode	40314	-250% to +250%	-20480 to +20480
G9.2.5	5 LIM 1 C2=+0[%]	Limit 1 for Comparator 2 in Window mode	40313	-250% to +250%	-20480 to +20480
G9.2.6	6 T C2 ON=0.0s	ON delay time for Comparator 2	40315	0.0 to 999s	0 to 9999
G9.2.7	7 SP C2 OF=+0[%]	Deactivation value of Comparator 2 in Normal mode	40313	-250% to +250%	-20480 to +20480
G9.2.8	8 T C2 OF=0.0s	OFF delay time for Comparator 2	40316	0.0 to 9999s	0 to 99999
G9.2.9	9 SEL FUNT C2=00	Selection of output function for Comparator 2	40317	00 to 15	0 to 15
G9.3.1	1 COMP 3 SEL=00	Source selection for Comparator 3	40320	00 to 22	0 to 22
G9.3.2	2 COMP 3 TYPE=0	Comparator 3 type selection	40321	0 to 1	0 to 1
G9.3.3	3 SP C3 ON=+100[%]	Activation value of Comparator 3 in Normal mode	40323	-250% to +250%	-20480 to +20480
G9.3.4	4 LIM 2 C3=+100[%]	Limit 2 for Comparator 3 in Window mode	40323	-250% to +250%	-20480 to +20480
G9.3.5	5 LIM 1 C3=+0[%]	Limit 1 for Comparator 3 in Window mode	40322	-250% to +250%	-20480 to +20480
G9.3.6	6 T C3 ON=0.0s	ON delay time for Comparator 3	40324	0.0 to 999s	0 to 9999
G9.3.7	7 SP C3 OF=+0[%]	Deactivation value of Comparator 3 in Normal mode	40322	-250% to +250%	-20480 to +20480
G9.3.8	8 T C3 OF=0.0s	OFF delay time for Comparator 3	40325	0.0 to 9999s	0 to 99999
G9.3.9	9 SEL FUNT C3=00	Selection of output function for Comparator 3	40326	00 to 15	0 to 15
G10.1	1 MIN1 SP=0%	Minimum speed limit 1	40102	-250% to Max. Speed 1	-20480 to G10.2

Parameter	Screen	Description	Address	Range	Modbus Range
G10.2	2 MAX1 SP=+100%	Maximum speed limit 1	40104	Min. Speed 1 to +250%	G10.1 to 20480
G10.3	3 MIN2 SP=-100%	Minimum speed limit 2	40103	-250% to Max. Speed 2	-20480 to G10.4
G10.4	4 MAX2 SP=+100%	Maximum speed limit 2	40105	Min. Speed 2 to +250%	G10.3 to 20480
G10.5	5 I LIMIT=___A	Current limit	40106	0.25 to 1.50In, OFF	2048 to 12291
G10.6	6 I LIM TO=OFF	Trip time because of current limit	40453	0 to 60s, OFF	0 to 600; 610
G10.7	7 I. MAX2=___A	Alternative current limit	40109	0.25 to 1.50In, OFF	2048 to 12291
G10.8	8 MI2 brSP=OFF	Change speed for I _{max} 2	40110	OFF=0%; +1 to +250%	0 to 20480
G10.9	9 MAX TOR=+150%	Torque limit	40107	0% to +250%	0 to +20480
G10.10	10 T LIM TO=OFF	Trip time because of torque limit	40455	0 to 60s, OFF	0 to 600; 610
G10.11	11 INVERSION ?=N	To enable speed inversion	40108	N Y	0 to 1
G10.12	12 ILIM RGN=OFF	Regenerating current limit	40112	OFF, 40.1%·In Motor to 200%·In Drive	4000, 4200 to 16384
G10.13	13 Ilim_rgnTO=OFF	Regenerating current limit trip time	40114	0 to 60s, OFF	0 to 600, 610
G10.14	14 T/I LIM SP = N	Torque limit algorithm	41864	N Y	0 to 1
G10.15	15 Rg TQ L = 150%	Torque limit range	41866	0 to 250%	0 to 20480
G11.1	1 SP LIM TO=OFF	Trip time because of speed limit	40452	0.1 to 60s, OFF	1 to 601
G11.2	2 STOP TO=OFF	Maximum time for stop limit	40454	OFF=0.0 to 999s	0 to 9999
G11.3	3 GND I LIMIT=10%	Ground fault detection	40456	OFF, 0 to 30% In	0 to 2458
G11.4	4 LOW VOLT=360V	Low input voltage level	40457	323 to 425V 586 to 621V	400V → 3230 to 4250 690V → 5860 to 6210
G11.5	5 LOW V TO=5s	Trip time because of low input voltage	40458	0.0 to 60s, OFF	0 to 600; 610
G11.6	6 HIGH VOLT=500V	High input voltage level	40459	418 to 587V 726 to 759V	400V → 4180 to 5870 690V → 7260 to 7590
G11.7	7 HI V TO=5s	Trip time because of high input voltage	40460	0.0 to 60s, OFF	0 to 600; 610
G11.8	8 Dlasy VO = 5s	Trip delay time due to output voltage imbalance	40463	0.0s to 10s; OFF	0 to 100; 101
G11.9	9 LOW V BHV=1	Performance in case of input power loss	40461	0 to 3	0 to 3
G11.10	10 PTC EXT ?=N	PTC motor option	40462	N Y	0 to 1
G11.11	11 PUMP OV=20.0A	Pump overload level	40289	0.0 to 3000A	0 to 30000
G11.12	12 Pmovl FIL=OFF	Filter for pump overload	40290	OFF=0; 0.1 to 20.0s	0 to 200
G11.13	13 Povi DLY=OFF	Trip delay time because of pump overload	40291	OFF=0; 1 to 999.9s	0 to 9999
G11.14	14 UNDERLOAD=N	To enable underload protection	42085	N Y	0 to 1
G11.15	15 ULD CUR=___A	Underload current	42086	(0.2 to 1.50)·In	0 to 12288
G11.16	16 ULD SPD=+100%	Underload speed	42087	+0.1% to +250%	9 to 20480
G11.17	17 ULD DELY=10s	Delay time to activate underload protection	42088	0 to 999s	0 to 9999
G11.18	18 DEC.Spdly=OFF	Speed decreasing delay time	40599	OFF=0; 1 to 10s	0; 1 to 10
G11.19	19 Sp.SRCH.I =10%	Increasing of speed searching	40464	2 to 40%·In	164 to 3276
G11.21	21 Vc Min. T = OFF	Minimum speed limit	40466	0.1 to 60.0, OFF	1 to 601
G11.22	22 Rdsq ls = 5.0s	Sets delay time before the trip.	40467	0.0 to 10.0, OFF	0-101
G12.1	1 AUTO RESET=N	Auto Reset	40571	N Y	0 to 1
G12.2	2 ATTEMP NUMBR=1	Number of Auto Reset attempts	40572	1 to 5	1 to 5
G12.3	3 R STR DEL=5s	Delay time before Auto Reset	40573	5 to 120s	5 to 120
G12.4	4 RS COUNT=15min	Reset time counter of Auto Reset attempts	40574	1 to 60min	1 to 60
G12.5	5 F1 AUTO RST=0	Selection of fault 1 to be reset	40575	0 to 27	0 to 27
G12.6	6 F2 AUTO RST=0	Selection of fault 2 to be reset	40576	0 to 27	0 to 27
G12.7	7 F3 AUTO RST=0	Selection of fault 3 to be reset	40577	0 to 27	0 to 27
G12.8	8 F4 AUTO RST=0	Selection of fault 4 to be reset	40578	0 to 27	0 to 27
G13.1	1 F0 NO FAULT	Register 1 of fault history	40432	-	-
G13.2	2 F0 NO FAULT	Register 2 of fault history	40433	-	-
G13.3	3 F0 NO FAULT	Register 3 of fault history	40434	-	-
G13.4	4 F0 NO FAULT	Register 4 of fault history	40435	-	-
G13.5	5 F0 NO FAULT	Register 5 of fault history	40436	-	-
G13.6	6 F0 NO FAULT	Register 6 of fault history	40437	-	-
G13.7	7 CLEAR FAULTS=N	G13.7 / Erase fault history	40438	N Y	0 to 1
G14.1	1 MREF 1=+10.0%	Multi-reference 1	40052	-250% to +250%	-20480 to +20480
G14.2	2 MREF 2=+20.0%	Multi-reference 2	40053	-250% to +250%	-20480 to +20480
G14.3	3 MREF 3=+30.0%	Multi-reference 3	40054	-250% to +250%	-20480 to +20480
G14.4	4 MREF 4=+40.0%	Multi-reference 4	40055	-250% to +250%	-20480 to +20480
G14.5	5 MREF 5=+50.0%	Multi-reference 5	40056	-250% to +250%	-20480 to +20480
G14.6	6 MREF 6=+60.0%	Multi-reference 6	40057	-250% to +250%	-20480 to +20480

Parameter	Screen	Description	Address	Range	Modbus Range
G14.7	7 MREF 7=+70.0%	Multi-reference 7	40058	-250% to +250%	-20480 to +20480
G15.1	1 INCH1=+0.00%	Inch speed 1	40092	-250% to +250%	-20480 to +20480
G15.2	2 INCH2=+0.00%	Inch speed 2	40093	-250% to +250%	-20480 to +20480
G15.3	3 INCH3=+0.00%	Inch speed 3	40094	-250% to +250%	-20480 to +20480
G16.1	1 SKIP 1=+0.0%	Skip frequency 1	40132	-250% to +250%	-20480 to +20480
G16.2	2 SKIP 2=+0.0%	Skip frequency 2	40133	-250% to +250%	-20480 to +20480
G16.3	3 SKIP BAND=OFF	Skip bandwidth	40134	OFF=0 to 20%	0 to 1638
G17.1	1 T DC BRAKE=OFF	Time for DC brake activation	40025	OFF=0.0 to 99s	0 to 990
G17.2	2 DC CURR=0%	Current applied to the brake	40022	0 to 100%	0 to 8192
G17.3	3 DC VOLTS=0.0%	Voltage applied to the brake	40023	0.0 to 25%	0 to 2048
G17.4	4 I HEATING=OFF	Non condensing heating current	40024	OFF=0.0 to 30%	0 to 2458
G17.5	5 DYN BRAK=N	Use of external brake	40026	N Y	0 to 1
G18.0	0 ENCODER = NO	Encoder	40475	N Y	0 to 1
G18.1	1 PULSES=1024	Pulses per revolution of the encoder	40337	200 to 8191	200 to 8191
G18.2	2 TYPE=DIFF	Encoder Type	40473	DIFF SING	0 to 1
G18.3	3 ENCOD FILTER=N	Encoder filter selection	40474	Yes NO	0 to 1
G19.1.1	1 TYPE CRTL=V/Hz	Selection of control type	40522	V/Hz VECT	0 to 1
G19.1.2	2 VECTOR CTR = PMC	Vector Control mode	40535	PMC AVC	0 to 1
G19.1.3	3 PMC = OL SP	Power Motor Control mode	40526	OL SP OL TQ CL SP CL TQ	1 to 4
G19.1.4	4 AVC = CL SP	Advance Vector Control mode	40527	CL SP CL TQ	3 to 4
G19.1.5	5 FRQ=4000Hz	Commutation frequency	40523	4000 to 8000 Hz	4000 to 8000
G19.1.6	6 PEWAVE=Y	Pewave control	40524	N Y	0 to 1
G19.1.8	8 AUTOTUNE=N	Motor parameter auto-tuning	40486	N Y	0 to 1
G19.1.9	9 OVERMODULATIO=N	Over-modulation	40493	N Y	0 to 1
G19.2.1	1 MIN FLUX = 100%	Minimum Flux	40502	40 to 100%	3277 to 8192
G19.2.3	3 V BOOST = 0.0%	Initial voltage	40592	0.0 to 100%	0 to 8192
G19.2.4	4 SLIP COMPENS=N	Slip compensation	40505	N Y	0 to 1
G19.2.7	7 I SLIP=2.0%	Current limit factor	40508	0.0 to 20.0%	0 to 1638
G19.2.9	9 STR FRQ = 0.0%	Initial frequency	40594	0.0% to 100%	0 to 8192
G19.2.11	11 DAMPref=10%	Damping reference	40506	0 a 10%	0 to 819
G19.2.13	13 CT Vbus = 800	Regeneration bus voltage	40021	For Vin = 230v, 390 to 410 For VIN = 400V / 500V 625 to 800V For VIN = 690V 950 to 1251V	Real value = Modbus value
G19.3.1	1 R STR=1%	Stator resistance (Rs)	40482	0.0 to 9.9%	0 to 811
G19.3.2	2 R. RTR = 0%	Rotor resistance (Rr)	40530	0.0% to 15%	0 to 15000
G19.3.3	3 Lm = 40%	Magnetizing inductance (Lm)	40531	40% to 800%	3276 to 65535
G19.3.4	4 LI = 0%	Stray Inductance	40534	0.0% to 50%	0 to 4096
G19.3.5	5 FL WEAK = 90%	Weakening field	40532	50% to 100%	4096 to 8192
G19.4.1	1 Kp Sp = 95%	Closed loop proportional speed constant.	40334	0.0% to 100%	0-8192
G19.4.2	2 Ki Sp = 95%	Speed closed loop integration time setting.	40335	0.0% to 100%	0-8192
G19.4.3	3 Kp Tq = 95%	Torque proportional closed loop constant.	40331	0.0% to 100%	0-8192
G19.4.4	4 Ki Tq = 95%	Torque closed loop time setting.	40332	0.0% to 100%	0-8192
G19.4.5	5 Kp I = 95%	Current closed loop proportional constant	40528	0.0% to 100%	0 to 8192
G19.4.6	6 Ki I = 15%	Current closed loop integration time setting	40529	0.0% to 100%	0 to 8192
G19.4.9	9 Flux tune=2.0%	Flux tuning	40333	0.0% to 10%	0-100
G20.0.1	1 COM CONTROL=0	Communications Control	40042	0-6	0-6
G20.1.1	1 COMMS T/O=OFF	Communication timeout MODBUS RTU	40413	OFF=0 to 250s	0 to 250
G20.1.2	2 COMM ADDR=10	Communication address	40414	1 to 255	1 to 255
G20.1.3	3 BAUDS=9600	Communication speed	40415	600 1200 2400 4800 9600 19200 38400	0 to 6

Parameter	Screen	Description	Address	Range	Modbus Range
G20.1.4	4 PARITY=NONE	Communication parity	40416	ODD NONE EVEN	0 to 2
	DispBR=4800	Display communication speed	40417	1200 2400 4800 9600	1 to 4
G20.2.1	1 NODE ADDR=10	Slave address in Profibus network	40852	1 to 255	1 to 255
G20.3.1	1 CO NODEID=0	Canopen slave address	41501	0-127	0-127
G20.3.2	2 CO BAUD=1Mbps	Bus speed connected to equipment	41502	1Mbps 10Mbps 125Mbps 250Mbps 500Mbps	0-4
G20.3.3	3 CO REF sp=+0.0%	Canopen Speed	41503	-	-32768 to +32768
G20.4.1	1 DN MAC ID=0	Devicenet MAC ID	41701	0-63	0-63
G20.4.2	2 DNBAUD=500kbps	Devicenet Baud rate	41702	125kbps 250kbps 500kbps	0-2
G20.4.3	3 CONTROL MODE=	Control modes	41401	0-2	0-2
G20.4.4	4 REFEREN MODE=0	Reference modes	41402	0-2	0-2
G20.4.5	5 FAULT MODE =2	Fault Mode	41404	FAULT IGNORE PE BEHV	0-2
G20.4.6	6 ASM IN=70	Input assembly	41704	70 71 100 150 151 152	0-5
G20.4.7	7 ASM- OUT=20	Output assembly	41705	20 21 100	0-2
G20.4.8	8 DNst=UNUSED	DeviceNet State	41703	0 to 4	0-4
G20.5.1	1 B/R F.O = 1 Mbps	Bus Speed connected to drive	41252	0 to 3	0-3
G20.6.1	01 Reg01 = 40001	Register 1	41966	40001-45400	40001-45400
G20.6.2	02 Reg02 = 40001	Register 2	41967	40001-45400	40001-45400
G20.6.3	03 Reg03 = 40001	Register 3	41968	40001-45400	40001-45400
G20.6.4	04 Reg04 = 40001	Register 4	41969	40001-45400	40001-45400
G20.6.5	05 Reg05 = 40001	Register 5	41970	40001-45400	40001-45400
G20.6.6	06 Reg06 = 40001	Register 6	41971	40001-45400	40001-45400
G20.6.7	07 Reg07 = 40001	Register 7	41972	40001-45400	40001-45400
G20.6.8	08 Reg08 = 40001	Register 8	41973	40001-45400	40001-45400
G20.6.9	09 Reg09 = 40001	Register 9	41974	40001-45400	40001-45400
G20.6.10	10 Reg10 = 40001	Register 10	41975	40001-45400	40001-45400
G20.6.11	11 Reg11 = 40001	Register 11	41976	40001-45400	40001-45400
G20.6.12	12 Reg12 = 40001	Register 12	41977	40001-45400	40001-45400
G20.6.13	13 Reg13 = 40001	Register 13	41978	40001-45400	40001-45400
G20.6.14	14 Reg14 = 40001	Register 14	41979	40001-45400	40001-45400
G20.6.15	15 Reg15 = 40001	Register 15	41980	40001-45400	40001-45400
G20.6.16	16 Reg16 = 40001	Register 16	41981	40001-45400	40001-45400
G20.6.17	17 Reg17 = 40001	Register 17	41982	40001-45400	40001-45400
G20.6.18	18 Reg18 = 40001	Register 18	41983	40001-45400	40001-45400
G20.6.19	19 Reg19 = 40001	Register 19	41984	40001-45400	40001-45400
G20.6.20	20 Reg20 = 40001	Register 20	41985	40001-45400	40001-45400
G20.6.21	21 Reg21 = 40001	Register 21	41986	40001-45400	40001-45400
G20.6.22	22 Reg22 = 40001	Register 22	41987	40001-45400	40001-45400
G20.6.23	23 Reg23 = 40001	Register 23	41988	40001-45400	40001-45400
G20.6.24	24 Reg24 = 40001	Register 24	41989	40001-45400	40001-45400
G20.6.25	25 Reg25 = 40001	Register 25	41990	40001-45400	40001-45400
G20.6.26	26 Reg26 = 40001	Register 26	41991	40001-45400	40001-45400
G20.6.27	27 Reg27 = 40001	Register 27	41992	40001-45400	40001-45400
G20.6.28	28 Reg28 = 40001	Register 28	41993	40001-45400	40001-45400
G20.6.29	29 Reg29 = 40001	Register 29	41994	40001-45400	40001-45400
G20.6.30	30 Reg30 = 40001	Register 30	41995	40001-45400	40001-45400
G20.6.31	31 Reg31 = 40001	Register 31	41996	40001-45400	40001-45400
G20.7.1	01 Reg01 = 0	Register 01	40801	0-65535	0-65535
G20.7.2	02 Reg02 = 0	Register 02	40802	0-65535	0-65535
G20.7.3	03 Reg03 = 0	Register 03	40803	0-65535	0-65535
G20.7.4	04 Reg04 = 0	Register 04	40804	0-65535	0-65535

Parameter	Screen	Description	Address	Range	Modbus Range
G20.7.5	05 Reg05 = 0	Register 05	40805	0-65535	0-65535
G20.7.6	06 Reg06 = 0	Register 06	40806	0-65535	0-65535
G20.7.7	07 Reg07 = 0	Register 07	40807	0-65535	0-65535
G20.7.8	08 Reg08 = 0	Register 08	40808	0-65535	0-65535
G20.7.9	09 Reg09 = 0	Register 09	40809	0-65535	0-65535
G20.7.10	10 Reg10 = 0	Register 10	40810	0-65535	0-65535
G20.7.11	11 Reg11 = 0	Register 11	40811	0-65535	0-65535
G20.7.12	12 Reg12 = 0	Register 12	40812	0-65535	0-65535
G20.7.13	13 Reg13 = 0	Register 13	40813	0-65535	0-65535
G20.7.14	14 Reg14 = 0	Register 14	40814	0-65535	0-65535
G20.7.15	15 Reg15 = 0	Register 15	40815	0-65535	0-65535
G20.7.16	16 Reg16 = 0	Register 16	40816	0-65535	0-65535
G20.7.17	17 Reg17 = 0	Register 17	40817	0-65535	0-65535
G20.7.18	18 Reg18 = 0	Register 18	40818	0-65535	0-65535
G20.7.19	19 Reg19 = 0	Register 19	40819	0-65535	0-65535
G20.7.20	20 Reg20 = 0	Register 20	40820	0-65535	0-65535
G20.7.21	21 Reg21 = 0	Register 21	40821	0-65535	0-65535
G20.7.22	22 Reg22 = 0	Register 22	40822	0-65535	0-65535
G20.7.23	23 Reg23 = 0	Register 23	40823	0-65535	0-65535
G20.7.24	24 Reg24 = 0	Register 24	40824	0-65535	0-65535
G20.7.25	25 Reg25 = 0	Register 25	40825	0-65535	0-65535
G20.7.26	26 Reg26 = 0	Register 26	40826	0-65535	0-65535
G20.7.27	27 Reg27 = 0	Register 27	40827	0-65535	0-65535
G20.7.28	28 Reg28 = 0	Register 28	40828	0-65535	0-65535
G20.7.29	29 Reg29 = 0	Register 29	40829	0-65535	0-65535
G20.7.30	30 Reg30 = 0	Register 30	40830	0-65535	0-65535
G20.7.31	31 Reg31 = 0	Register 31	40831	0-65535	0-65535
G21.1.1	1 AUTOMATIC IP=Y	To enable automatic assignation of parameters	40922	N Y	0 to 1
-	lxxx.yyy.zzz.hhh	Present IP address of the drive	40923 – A 40924 – B 40925 – C 40926 – D	-	-
-	Sxxx.yyy.zzz.hhh	Present Subnet Mask of the drive	40927 – A 40928 – B 40929 – C 40930 – D	-	-
-	Gxxx.yyy.zzz.hhh	Present Gateway of the drive	40931 – A 40932 – B 40933 – C 40934 – D	-	-
G21.1.2	2 IP MANU. A=192	IP address (A)	40374	0 to 255	0 to 255
G21.1.3	3 IP MANU. B=168	IP address (B)	40375	0 to 255	0 to 255
G21.1.4	4 IP MANU. C=1	IP address (C)	40376	0 to 255	0 to 255
G21.1.5	5 IP MANU. D=143	IP address (D)	40377	0 to 255	0 to 255
G21.1.6	6 SUBNET A=255	Subnet Mask address (A)	40378	0 to 255	0 to 255
G21.1.7	7 SUBNET B=255	Subnet Mask address (B)	40379	0 to 255	0 to 255
G21.1.8	8 SUBNET C=255	Subnet Mask address (C)	40380	0 to 255	0 to 255
G21.1.9	9 SUBNET D=0	Subnet Mask address (D)	40381	0 to 255	0 to 255
G21.1.10	10 GATEWAY A=0	Gateway address (A)	40382	0 to 255	0 to 255
G21.1.11	11 GATEWAY B=0	Gateway address (B)	40383	0 to 255	0 to 255
G21.1.12	12 GATEWAY C=0	Gateway address (C)	40384	0 to 255	0 to 255
G21.1.13	13 GATEWAY D=0	Gateway address (D)	40385	0 to 255	0 to 255
G21.1.14	14 MAC A=0	MAC address (A)	40386	0 to 255	0 to 255
G21.1.15	15 MAC B=80	MAC address (B)	40387	0 to 255	0 to 255
G21.1.16	16 MAC C=194	MAC address (C)	40388	0 to 255	0 to 255
G21.1.17	17 MAC D=114	MAC address (D)	40389	0 to 255	0 to 255
G21.1.18	18 MAC E=X	MAC address (E)	40390	0 to 255	0 to 255
G21.1.19	19 MAC F=Y	MAC address (F)	40391	0 to 255	0 to 255
G21.2.1	1 MIptout=OFF	Communication timeout MODBUS TCP	41451	OFF=0 to 600s	0 to 600
G21.3.1	1 CONTROL MODE=0	Control mode of the drive	41401	LOCAL NETWORK NET DECIDES	0 to 2
G21.3.2	2 REFEREN.MODE=0	Reference mode of the drive	41402	LOCAL NETWORK NET DECIDES	0 to 2
G21.3.3	3 FAULT MODE = 2	Fault Mode	41404	FAULT IGNORE PE BEHV	0 to 2

5.4.3. Visualization Parameters

Parameter	Screen	Description	Address	Modbus Range
STATUS LINE	OFF 0.0A +0.0%	Present status of the drive.	40219	0 to 201
Modbus value for drive status, warning and fault messages.				
Modbus value → STATUS MESSAGE				
0 → OFF	4 → DEC	12 → DCB	42 → IN2	
1 → ON	5 → SPG	15 → TBR	43 → IN3	
2 → ACL	6 → EST	16 → DLY	49 → HEA	
3 → RUN	10 → SPN	41 → IN1		
Note: See description of the status messages in section 8.1.				
Modbus value → WARNING MESSAGE				
61 → MOL	66 → TLT	70 → AVI	91 → S2L	
63 → MOC	67 → VLT	71 → OVV		
64 → DOC	68 → ACO	72 → UNV		
65 → ILT	69 → AVO	90 → S1L		
Note: See description of the warning messages in section 8.2.				
Modbus value → FAULT MESSAGE				
120 → NFL	140 → F20	160 → F40	180 → F60	
121 → F01	141 → F21	161 → F41	181 → F61	
122 → F02	142 → F22	162 → F42	182 → F62	
123 → F03	143 → F23	163 → F43	183 → F63	
124 → F04	144 → F24	164 → F44	184 → F64	
125 → F05	145 → F25	165 → F45	185 → F65	
126 → F06	146 → F26	166 → F46	186 → F66	
127 → F07	147 → F27	167 → F47	187 → F67	
128 → F08	148 → F28	168 → F48	188 → F68	
129 → F09	149 → F29	169 → F49	189 → F69	
130 → F10	150 → F30	170 → F50	190 → F70	
131 → F11	151 → F31	171 → F51	191 → F71	
132 → F12	152 → F32	172 → F52	192 → F72	
133 → F13	153 → F33	173 → F53	193 → F73	
134 → F14	154 → F34	174 → F54	194 → F74	
135 → F15	155 → F35	175 → F55	195 → F75	
136 → F16	156 → F36	176 → F56	196 → F76	
137 → F17	157 → F37	177 → F57	197 → F77	
138 → F18	158 → F38	178 → F58	198 → F78	
139 → F19	159 → F39	179 → F59		
Note: See description of the fault messages in section 11.				
STATUS LINE	OFF 0.0A +0.0%	Motor output current. (Corresponds with SV1.6)	40163	Real value = (Modbus value / 10)
STATUS LINE	OFF 0.0A +0.0%	Motor output speed (in %). (Corresponds with SV1.3).	40170	8192 = 100% of motor rated speed

Note for drive status

Equipment status.

Parameter Equipment Status has Word size like the rest of Modbus parameters.

The information of the previous tables about status messages, warning and fault messages will be displayed by means of the Low Byte (LSB).

The High Byte (MSB) is reserved for internal use (bit by bit). Interesting information for the user is below:

- Bit 15:
 - 0 → Drive with no fault.
 - 1 → Drive in fault status.
- Bit 12:
 - 0 → Drive started.
 - 1 → Drive stopped.

Alternation between two states.

During the standard running of the equipment, the drive status value will appear in a stable and continuous way, only changing when the drive status changes (from 'ACL' (Accelerating) to 'RUN', for example). Nevertheless, there are two situations where the status value intermittently alternates between two states:

- First case: If the equipment presents a warning, this one will appear by alternating with the equipment status, for example, normal status 'RUN' and the warning 'ILT' will be alternatively and intermittently displayed.
- Second case: If a fault occurs, the last status value before the fault has occurred will be shown in alternation with the present fault number. For example, normal status 'RUN' and 'F40' will be alternatively and intermittently displayed.

Parameter	Screen	Description	Address	Modbus Range
SV1.1	Sp Ref = +000%	Value of present speed reference.	40162	8192 = 100% of motor rated speed
SV1.2	Tq Ref=000	Torque Reference Value	41316	-20480 to +20480
SV1.3	Mtr Speed = +0rpm	It shows the motor speed in rpm.	40169	Real value = Modbus value
SV1.4	Mtr Sp = +0.0%	It shows the motor speed in %.	40170	8192 = 100% of motor rated speed
SV1.5	Mtr Freq = +0.0Hz	Frequency at which motor is running.	40167	Real value = Modbus value
SV1.6	Mtr Vout = 0V	It shows the present voltage applied to the motor.	40166	Real value = Modbus value
SV1.7	Mtr Iout = 0.0A	Present current flowing to the motor.	40163	Real value = (Modbus value / 10)
SV1.8	Mtr Torqe = 0.0%	It shows the present torque applied to the motor.	40164	8192 = 100% of motor rated torque
SV1.9	Mtr Pfactr = 0.0	It shows the power factor of the motor.	40168	Real value = (Modbus value / 10)
SV1.10	Mtr Pwr = +0.0kW	Instantaneous power consumption of the motor.	40165	Real value = (Modbus value / 10)
SV1.11	0.0A 0.0A 0.0A	Instantaneous current per phase of the motor (U, V y W).	40177 → U 40178 → V 40179 → W	Real value = (Modbus value / 10)
SV1.12	Vmt= 0 0 0V	Compound Instantaneous voltage (UV, VW, UW).	40180 → UV 40181 → VW 40182 → UW	Real value = Modbus value
SV1.13	PTC Motor = 0	It shows if the motor PTC is connected or not.	40218	0 to 1
SV1.14	Motor T. = 0.0%	Theoretical heating level of the motor.	40173	8192 = 100% of motor temperature
SV1.15	Enco. Pulso = 0	It shows the encoder pulses	40337	Real value = Modbus value
SV1.16	Clspe d = 0 rpm	Real speed measured by the encoder	40336	Real value = Modbus value
SV2.1	390 390 390V	Input instantaneous voltage.	40183 → RS 40184 → ST 40185 → RT	Real value = Modbus value
SV2.2	Inp Vol = 390V	Average input voltage to the drive.	-	Non accessible from this SW version
SV2.3	50.0 50.0 50.0Hz	Frequency of input voltage.	40159 → RS 40160 → ST 40161 → RT	Real value = (Modbus value / 10)
SV2.4	Bus vol = 540V	DC Link voltage of the drive.	40171	Real value = Modbus value
SV2.5	IGBT Temp = +23°C	Temperature measured at the power stage.	40172	Real value = Modbus value
SV2.6	Drive Temp = +26°C	Internal temperature of the drive.	40240	Real value = (Modbus value / 100)
SV3.1	ANLG IN1 = +0.0V	Average value of the Analogue Input 1.	40186	Real value = (Modbus value / 1000)
SV3.2	AIN1 Refr = +0.00%	Speed reference or PID setpoint proportional to the AI1.	40190	8192 = 100% maximum range of the Analogue Input 1
SV3.3	AIN1 S = +0.00l/s	Value of sensor 1 associated to the AI1.	40262	Real value = (Modbus value / 10)
SV3.4	ANLG IN2 = +0.0V	Average value of the Analogue Input 2.	40187	Real value = (Modbus value / 1000)
SV3.5	AIN2 Refr = +0.00%	Speed reference or PID setpoint proportional to the AI2.	40191	8192 = 100% maximum range of the Analogue Input 2
SV3.6	AIN 2 S = +0.00Bar	Value of sensor 2 associated to the AI2.	40263	Real value = (Modbus value / 10)
SV3.7	ANL OUT1 = +4.0mA	It shows the value of the Analogue Output 1.	40192	Real value = (Modbus value / 1000)
SV3.8	AOUT1 Refer = +0.0%	Value of the magnitude associated to the AO1.	40194	8192 = 100% maximum range of the Analogue Output 1
SV3.9	ANL OUT2 = +4.0mA	It shows the value of the Analogue Output 2.	40193	Real value = (Modbus value / 1000)
SV3.10	AOUT2 Refer = +0.0%	Value of the magnitude associated to the AO2.	40195	8192 = 100% maximum range of the Analogue Output 2
SV3.11	DI: 000000 0	Digital Inputs and PTC status.	40196	LSB → BIT0 → MF11 BIT6 → PTC 0 to 1
SV3.12	Relays 1-3: X0X	Output relays status.	40197	BIT 0 → R1; Range from 0 to 1 BIT 1 → R2; Range from 0 to 1 BIT 2 → R3; Range from 0 to 1
SV3.13	Speed M = +0.000m/s	Machine speed associated to the motor (speed motor in engine. Units).	-	
SV3.14	Modbus Traffic:0	Traffic in user port (Modbus RTU)	40418	0 to 1
SV3.15	Display_traffi = 0	Presence of the Display Unit	40422	0 to 1
SV4.1	Actual Fault = 00	Present code fault.	40235	Fault number
SV4.2	Drive Curr = 170A	Drive rated current.	40209	Real value = (Modbus value / 10)
SV4.3	Drive Volt = 400V	It shows the drive rated voltage.	40210	Real value = (Modbus value / 10)
SV4.4	S/W	Software version installed into the equipment.	40206	Real value = Modbus value
SV4.5	H/W y.y	It shows the hardware version of the equipment.	40207	Real value = (Modbus value / 100)
SV4.6	PID R% = +0.0%	PID setpoint value of the equipment standard program.	40204	8192 = 100% maximum range of AI
SV4.7	PID F% = +0.0%	PID feedback value of the equipment standard program.	40205	8192 = 100% maximum range of AI

Parameter	Screen	Description	Address	Modbus Range
SV4.8	PID Error = +0.0%	Error value in PID mode.	40203	8192 = 100% maximum range of AI
SV4.9	Comparators: 000	Status of the three comparators.	40232 → C1 40233 → C2 40234 → C3	0 to 1
SV4.10	FLT.STAT.=NO FLT	Drive status before occurring the fault	40559	0 to 17 (See fault message list)
SV4.11	Fault Diag.=N	Fault diagnosis	41601	0 to 1
SV5.1	Local Sp = +100%	Speed reference in local mode.	40124	-20480 to 20480
SV5.2	PID Local = +100%	PID setpoint in local mode.	40149	0 to 32760
SV5.3	Mref 1 = +10.0%	Speed value assigned to Multi-reference 1.	40052	-20480 to 20480
SV5.4	Mref 2 = +20.0%	Speed value assigned to Multi-reference 2.	40053	-20480 to 20480
SV5.5	Mref 3 = +30.0%	Speed value assigned to Multi-reference 3.	40054	-20480 to 20480
SV5.6	Mref 4 = +40.0%	Speed value assigned to Multi-reference 4.	40055	-20480 to 20480
SV5.7	Mref 5 = +50.0%	Speed value assigned to Multi-reference 5.	40056	-20480 to 20480
SV5.8	Mref 6 = +60.0%	Speed value assigned to Multi-reference 6.	40057	-20480 to 20480
SV5.9	Mref 7 = +70.0%	Speed value assigned to Multi-reference 7.	40058	-20480 to 20480
SV5.10	Inch Spd1 = 0.00%	Inch speed 1.	40092	-20480 to 20480
SV5.11	Inch Spd2 = 0.00%	Inch speed 2.	40093	-20480 to 20480
SV5.12	Inch Spd3 = 0.00%	Inch speed 3.	40094	-20480 to 20480
SV5.13	PMP manSP=+0.0%	LOCAL manual speed reference.	42042	-20480 to 20480
SV5.14	PMP Mre1=0.0%	Local setpoint 1 of PID. Multi-reference 1.	42151	0 to 32760
SV5.15	PMP Mre2=0.0%	Local setpoint 2 of PID. Multi-reference 2.	42152	0 to 32760
SV5.16	PMP Mre3=0.0%	Local setpoint 3 of PID. Multi-reference 3.	42153	0 to 32760
SV5.17	PMP Mre4=0.0%	Local setpoint 4 of PID. Multi-reference 4.	42154	0 to 32760
SV5.18	PMP Mre5=0.0%	Local setpoint 5 of PID. Multi-reference 5.	42155	0 to 32760
SV5.19	PMP Mre6=0.0%	Local setpoint 6 of PID. Multi-reference 6.	42156	0 to 32760
SV5.20	PMP Mre7=0.0%	Local setpoint 7 of PID. Multi-reference 7.	42157	0 to 32760
SV5.21	PMP Mre8=0.0%	Local setpoint 8 of PID. Multi-reference 8.	42158	0 to 32760
SV5.22	T AutOFF=OFF	Time for Automatic Stop.	42044	0 to 999
SV5.23	TIME OFF=OFF	It shows the resting time in minutes for the automatic stopping of the system.	42356	0 to 6000
SV5.24	MAX flow=1000l/s	Level of maximum flow.	42143	0 to 32760
SV5.25	RESET LEVL=+100%	Reset level for the flow control algorithm.	42145	0 to 100
SV5.26	SLEP FLO=0.0l/s	Flow level to sleep the drive.	42324	0 to 32760
SV6.1	TOT= d h	Total time during which the drive is running (RUN).	40550 → Days 40551 → Hours	Days → Real value = Modbus value Hours → 1 = 0.1 hours
SV6.2	PAR= d h	Partial time during which the drive is running (RUN).	40552 → Days 40553 → Hours	Days → Real value = Modbus value Hours → 1 = 0.1 hours
SV6.3	CLEAR PARTIAL=N	To reset the counter of partial time for running status (RUN).	40554	0 to 1
SV6.4	TOTAL ENERGY	Total drive energy counter in kW	41552	0 to 999kW
SV6.4	TOTAL ENERGY	Total drive energy counter in MW	41553	1MW to 999MW
SV6.4	TOTAL ENERGY	Total drive energy counter in GW	41554	1GB to 5000GB
SV6.5.1	PARTIAL ENERGY	Partial drive energy counter in kW	41556	0 to 999kW
SV6.5.1	PARTIAL ENERGY	Partial drive energy counter in MW	41557	1MW to 999MW
SV6.5.1	PARTIAL ENERGY	Partial drive energy counter in GW	41558	1GB to 5000GB
SV6.5.2	RSET PRTL ENRG=N	Partial drive energy counter reset	41559	0 to 1

6. FAULT MESSAGES. DESCRIPTIONS AND ACTIONS

When a fault occurs the SD700 will stop the motor and show the generated fault on the display. You can display this fault in the programming line (lower line) while motor current and the speed values at the moment of the fault are displayed in the upper line.

It is possible to navigate through the additional display lines to access other status parameters without resetting the fault. These additional status parameters offer further information about the moment at which the fault occurred. Additionally, the FAULT led will blink and the fault message will be displayed until the fault is remedied and the drive is reset.

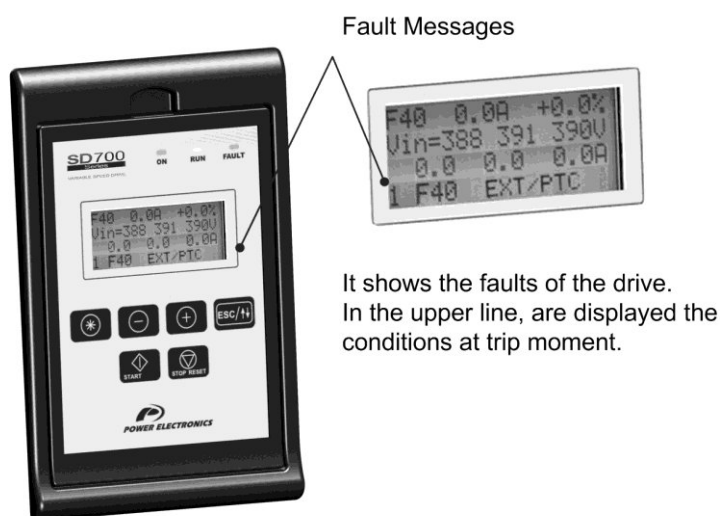

SD70ITC0113AI

Figure 6.1 Fault displaying – Programming Line

6.1. Description of Fault List

DISPLAY	DESCRIPTION
F0 NO FAULT	Drive is operative. There is no fault.
F1 I LIM FLT	Output current has reached a dangerous level. Its value is above 220% of the drive rated current. Protection is activated instantaneously.
F2 V LIM FLT	DC Bus voltage has reached a dangerous level >850VDC. Hardware Protection. Drive will turn off the output to the motor.
F3 PDINT FLT	DC Bus voltage and the output current of the equipment have reached dangerous levels.
F4 OVERLOAD U+	Internal protection within the appropriate IGBT semiconductor has acted.
F5 OVERLOAD U-	
F6 OVERLOAD V+	
F7 OVERLOAD V-	
F8 OVERLOAD W+	
F9 OVERLOAD W-	
F10 SAFE STOP	Automatic internal protection of several of the IGBT semiconductors has acted or safe stop contact of the drive (connected to an external circuit by the user) has been activated (for example, emergency stop).
F11 VIN LOSS	Power supply loss of any input phase for a time higher than 20ms has occurred.
F12 IMB V IN	Input voltage imbalance greater than $\pm 10\%$ of average input power supply of SD700 for a time higher than 100ms.
F13 HI V IN	Average supply voltage has exceeded the value set in 'G11.6 HIGH VOLT' for greater than the time set in 'G11.7 HIGH V TO'.
F14 LW V IN	Average supply voltage is lower than the value set in 'G11.4 LOW VOLT' for greater than the time set in 'G11.5 LOW V TO'.
F15 CURL Vdc	Unstable bus voltage. There is a DC Bus voltage ripple higher than 100VDC for more than 1.1sec.
F16 HI Vdc	DC Bus voltage has exceeded critical operating level (>850VDC). Software Protection.
F17 LW Vdc	DC Bus voltage is lower than critical operating level (<350VDC).

DISPLAY	DESCRIPTION
F18 IMB V OUT	Voltage imbalance of more than $\pm 5\%$ of the average drive output average voltage for a time higher than 100ms.
F19 IMB I OUT	Current imbalance of more than $\pm 25\%$ of the average output motor current for a time higher than 1s.
F20 GROUND FLT	Current level to the ground has exceeded the level set in 'G11.3 GND I LIMIT'.
F21 I LIM T/O	Motor current has exceeded the current limit set in 'G10.5 I LIMIT' for the time set in 'G10.6 I LIM TO'.
F22 TQ LIM T/O	Motor torque has exceeded the torque limit set in parameter 'G10.7 MAX TOR' for the time set in 'G10.8 T LIMT TO'.
F23 Min Spd Lm	Motor speed does not reach the speed limit (parameters G10.1 to G10.4) for the time set in 'G11.21 SP Min. T'.
F25 MTR O/L	Motor overload calculated by SD700 thermal model has exceeded 110%.
F27 DL SMTH	DC Bus has not charged in the expected time.
F28 Ir.LIM TO	Motor load current has exceeded the regenerating current limit set in 'G10.12 ILIM RGN' for the time set in 'G10.13 Ilim_rgnTO'.
F29 DSP FLT	DSP has detected wrong data.
F30 WATCHDOG	An unknown fault has reset the microprocessor of the control board.
F31 SCR L1	Trip on conduction status of thyristor 1. The thyristor has not turned on correctly.
F32 SCR L2	Trip on conduction status of thyristor 2. The thyristor has not turned on correctly.
F33 SCR L3	Trip on conduction status of thyristor 3. The thyristor has not turned on correctly.
F34 IGBT TEMP	IGBT internal temperature has reached a level of 110°C (See parameter SV2.4).
F35 PHS L1 LOS	Input phase L1 is not present. Phase fault.
F36 PHS L2 LOS	Input phase L2 is not present. Phase fault.
F37 PHS L3 LOS	Input phase L3 is not present. Phase fault.
F38 ENCOD LOST	Incorrect reading made by the encoder working in closed loop.
F40 EXT / PTC	External trip device or motor PTC has operated (terminals 8 and 9). Values lower than $90\Omega \pm 10\%$ or higher than $1K5 \pm 10\%$ generate the fault.
F41 COMMS TRIP	Trip generated through RS232 or RS485 communication. Master (PLC or PC) is generating a fault in the SD700 through serial communication.
F42 AIN1 LOSS	The SD700 is not receiving a signal on analogue input 1 and 'G4.2.14 AIN1 LOSS' is set to 'Yes'. The signal connected to this input has been lost.
F43 AIN2 LOSS	The SD700 is not receiving a signal on the analogue input 2 and 'G4.3.14 AIN2 LOSS' is set to 'Yes'. The signal connected to this input has been lost.
F44 CAL FLT	Internal reference voltage levels are wrong.
F45 STOP T/O	Trip generated due to excessive stopping time. The elapsed time from stop signal activation has exceeded the value set in parameter 'G11.2 STOP TO'.
F46 EEPROM FLT	Non-volatile memory (EEPROM) is faulty.
F47 COMMS T/O	Trip generated due to excessive delay of serial communication. The elapsed time from the last valid data transmission has exceeded the time set in parameter 'G20.2 COMMS T/O'.
F48 SPI COM	Trip because data bus transfer is wrong.
F49 SPD LIMIT MAX	Motor speed has exceeded the speed limit (parameters G10.1 to G10.4) for the time set in 'G11.1 SP LIM TO'.
F50 PSU FAULT	Internal power supply is not supplying the correct voltage. One voltage level has decreased to zero value for 100ms approx.
F51 SCR TEMP	Rectifier heat sink temperature has reached a dangerous level.
F52 FAN P.SUPP	A fault in the power supply to the cooling fans has occurred.
F53 INTRNL TEMP	Internal temperature of the SD700 control electronics chamber has reached a dangerous level.
F54 WATCHDOG	Internal fault of the microcontroller.
F55 DO Feedbck	The digital input configured as "Dig Output FB" has not received the feedback of the digital output set in parameter G8.1.34 before the time configured in parameter G8.1.35.
F56 EMERG.STOP	Digital input configured as 'EXTERN EMERGE' has been activated (NC contact).
F57 PUMP OvLd	This fault is generated when the output current of the drive is higher than the current set in 'G11.11 PUMP OV' during the time adjusted in 'G11.13 Powl DLY'.
F58 PROFI.TOUT	Once the Profibus Master has configured the drive as Profibus Slave, and after establishing the connection, which is always permanent, if the communication is cut off, the drive trips by Timeout fault.
F60 EIP/DN T.O	The connection between the drive (server) and the Ethernet/IP Client (PLC) has been lost. If there is not a configuration to indicate the contrary, the CIP standard forces the drive to stop the motor and to trip because of Timeout fault.
F61 NO INPUT V	This fault will be shown in the display of the SD700 when the start command is activated and the input voltage applied to the drive is lost, and the drive is powered by the External 24V Power Supply.
F73 FLT COMP 1	Failure of the comparator 1
F74 FLT COMP 2	Failure of the comparator 2
F75 FLT COMP 3	Failure of the comparator 3
F76 SLAVE O.F	The master of the optical fiber network shows this fault if one of their slaves fails.
F77 OPT FIB TO	Timeout of the optical fiber has been exceeded.
F78 TMP FREMAQ	Temperature of the filter has reached a dangerous value.

6.2. Procedure for Fault Solutions

DISPLAY	POSSIBLE CAUSE	ACTIONS
F0 NO FAULT		
F1 I LIM FLT	Motor output short circuit:	Check output cables and motor for possible wiring faults or short circuits.
	Wiring fault.	
	Circuit fault.	
	Motor fault.	
F2 V LIM FLT	High voltage peak on the input.	Check conditions of input power supply. Decrease deceleration ramps.
	High load regeneration.	
	Deceleration ramp too high (parameters 'G5.2 DECEL1' and 'G5.4 DECEL2').	
F3 PDINT FLT	See faults F1 and F2.	See faults F1 and F2.
F4 OVERLOAD U+ F5 OVERLOAD U- F6 OVERLOAD V+ F7 OVERLOAD V- F8 OVERLOAD W+ F9 OVERLOAD W-	Short circuit.	Check if there are possible wiring faults or a motor fault. If the fault persists after disconnecting output wires request technical assistance.
	Extreme over current, equipment overload.	
	Wiring fault; circuit fault.	
	Desaturation of IGBT; IGBT fault.	
F10 SAFE STOP	See possible causes for faults F4 – F9.	See actions for F4 – F9.
	Safe stop contact of the drive has been activated.	Revise the external circuit, where the safe stop contact is connected, that produces the activation of this contact into the drive.
F11 VIN LOSS	Input power is incorrect, damaged fuses.	Check conditions of input power supply.
	Input wiring is incorrect.	Check wiring.
F12 IMB V IN	Input power is incorrect, damaged fuses.	Check conditions of input power supply.
	Input wiring is incorrect.	Check wiring.
F13 HI V IN	Input power is incorrect.	Check input power conditions.
	Incorrect setting of parameter 'G11.6 HIGH VOLT'.	Check parameters settings.
F14 LW V IN	Input power is incorrect, damaged fuses.	Check input power conditions.
	Incorrect setting of parameter 'G11.4 LOW VOLT'.	Check parameters settings.
F15 CURL Vdc	Input power is incorrect.	Check input power conditions, load type of the application, and all of the motor mechanical parts. If the fault persists after disconnecting output wires, request technical assistance.
	Motor is driving an unstable load.	
	One of the input fuses is damaged.	
F16 HI Vdc	High voltage peak on the input.	Check conditions of input power supply.
	High load regeneration.	Check stop conditions of the drive.
	Deceleration ramp too high (parameters 'G5.2 DECEL1' and 'G5.4 DECEL2').	Decrease deceleration ramps.
F17 LW Vdc	Input power is wrong, damaged fuses.	Check conditions of input power supply.
F18 IMB V OUT	Motor is driving an unstable load.	Check motor circuit completely in case of possible wiring faults or motor fault. If the fault persists after disconnecting output wires, request technical assistance.
	Motor wiring fault.	
	Motor is wrong.	
F19 IMB I OUT	Motor is supporting unstable loads.	Check motor circuit completely in case of possible wiring faults or motor fault.
	Motor wiring fault.	
	Motor is wrong.	
F20 GROUND FLT	Motor or wiring has short-circuited to ground.	Disconnect the motor and wiring of the SD700 and check motor insulation.
	Ground is incorrectly connected or wrong.	Check and improve the ground connection system.
F21 I LIM T/O	Motor stalled. Heavy load.	Check the motor load.
	Motor mechanical brake is coupled.	Increase maximum current limit.
F22 TQ LIM T/O	Motor stalled. Heavy load.	Check the motor load.
	Motor mechanical brake is coupled.	Increase maximum torque limit.
F23 Min Spd Lm	Speed reference is lower or equal than the speed limit.	Check the reference source and the motor load.
	Motor speed is out of control or motor is not accelerating due to the load.	Verify speed limits.

DISPLAY	POSSIBLE CAUSE	ACTIONS
F25 MTR O/L	High current used by the motor due to heavy load.	Check the motor load. Check the setting of parameters 'G2.1 MTR CUR' and 'G2.7 MTR COOL' relating to the motor thermal model. Increasing the parameter 'G2.7 MTR COOL', can be undertaken when there is a motor PTC fitted and it is connected to the SD700.
	The load exceeds the capacity of motor cooling under normal operating conditions.	
	Incorrect setting of the thermal model parameters.	
	Phase loss of the motor or a fault in motor windings.	
F27 DL SMTH	Potential damage to the soft charge resistors of the SD700.	Try to reset the fault. Disconnect and re-connect again the input power. If the fault persists contact Power Electronics for technical service.
F28 Ir.LIM TO	Excessive regeneration is produced due to deceleration ramp to high.	Decrease deceleration ramp. Revise the setting of parameters related to regenerating current limitation (G10.12 and G10.13).
F29 DSP FLT	Input power fault.	Disconnect and connect again SD700 input power. If the same fault appears, initialize all of the parameters (parameter 'G1.5 INITIALISE') and connect the input power again. If the fault persists, request technical assistance.
	Parameter setting is incoherent.	
F30 WATCHDOG	Input power fault.	Reset the fault; If the fault persists, request technical assistance.
F31 SCR L1	A conduction fault has been produced in the corresponding thyristor. The thyristor is OFF when it should be on.	Try to reset the fault. Disconnect and re-connect again the input power. If the fault persists request technical assistance.
F32 SCR L2		
F33 SCR L3		
F34 IGBT TEMP	Blocked or poor ventilation.	Check if there is an object blocking ventilation. Improve the cooling.
	Heat sink and cooling fan fault on the SD700.	Check if the heat sink and the cooling fan are operating correctly.
	Ambient temperature is higher than 50°C.	Check the cooling and thermal conditions. Request technical assistance.
F35 PHS L1 LOS	Input phase L1 is not connected correctly or there is no voltage on it.	Verify the wiring of the input power supply of the drive. Check input voltage and input fuses.
F36 PHS L2 LOS	Input phase L2 is not connected correctly or there is no voltage in it.	
F37 PHS L3 LOS	Input phase L3 is not connected correctly or there is no voltage in it.	
F38 ENCOD LOST	Incorrect reading made by the encoder	Check the encoder wiring and its power supply
F40 EXT / PTC	External trip device has operated.	Check the external trip switch (if exists).
	Motor is overheated (motor load exceeds the cooling capacity at operating speed).	Check motor temperature. To reset the fault the motor must be return to normal temperature.
	Fault in sensor connection.	Check sensor wiring.
F41 COMMS TRIP	Trip generated by a computer through serial communication.	Disconnect the SD700 from the communication network and verify if the fault is generated again.
F42 AIN1 LOSS	Analogue input cable has been come loose or disconnected (terminals 10 and 11).	Verify the wiring and the device which provides the analogue signal.
F43 AIN2 LOSS	Analogue input cable has been come loose or disconnected (T12 and T13).	Verify the wiring and the device which provides the analogue signal.
F44 CAL FLT	SD700 fault.	Verify drive select. Request technical assistance.
F45 STOP T/O	Deceleration ramps (parameters 'G5.2 DECEL1' and 'G5.4 DECEL2') are too slow.	Verify that the time set in parameter 'G11.2 STOP TO' to stop the system after setting deceleration ramps and checking the system performance.
	SD700 is voltage limiting voltage due to regeneration from the motor.	
F46 EEPROM FLT	Integrated circuit fault.	Request technical assistance.
F47 COMMS T/O	Communications cable has been come loose or cut.	Verify the wiring of communications system.
	Master device has not sent valid data in the required frame or it has sent incorrect data.	Verify the data and settings of the master device.
F48 SPI COM	Input power fault.	Reset the equipment and if the fault persists request technical assistance.

DISPLAY	POSSIBLE CAUSE	ACTIONS
F49 SPD LIMIT MAX	Speed reference is higher or equal than the speed limit.	Check the reference source and the motor load.
	Motor speed is out of control or motor is accelerating because of the load.	Verify speed limits.
F50 PSU FAULT	Damaged power supply.	Reset the equipment and if the fault persists request technical assistance.
F51 SCR TEMP	Temperature limits for SD700 rectifier have been exceeded.	Verify that the ambient conditions are proper for the equipment. Be sure that there is nothing obstructing the cooling fans (dust, papers, dirt, etc) and that these rotate correctly.
F52 FAN P.SUPP	Fans of the equipment are operating wrong.	Verify that fans are not obstructed. Check that fans are not dirty and rotate correctly.
	Power supply of the fans has been overheated.	Wait for the temperature of the power supply decreases down to a value in normal conditions and restart it. You can disconnect the equipment, connect it again, and restart the power supply again. If the fault persists request technical assistance of Power Electronics.
F53 INTRNL TEMP	The limit of internal temperature of the electronics chamber has been exceeded.	Verify that the ambient conditions are proper for the equipment. Be sure that there is nothing obstructing the cooling fans (dust, papers, dirt in general) and that these rotate correctly.
F54 WATCHDOG	A fault in the microcontroller has occurred.	Disconnect and re-connect the input power of the drive. If the fault persists request technical assistance of Power Electronics.
F55 DO Feedbck	Timeout of the parameter G8.1.35 has been exceeded.	Check the feedback of the digital output configured in the parameter G8.1.34.
F56 EMERG.STOP	An external trip has been produced by closing a contact on the digital input configured in this option.	Verify the wiring of digital input. Check the installation.
F57 PUMP OvLd	High current used by the motor due to heavy load.	Check the motor load. Check if the motor cooling is appropriate. Check the setting of the parameters related to pump overload in group G11.
	The load exceeds the capacity of the motor cooling under normal operating conditions.	
	Incorrect setting of the parameters related to pump overload.	
	Phase loss of the motor or a fault in motor windings.	
F58 PROFI.TOUT	The communication between Profibus Master and Slave is cut off.	Revise the Profibus wiring and the configuration in the Master (PLC).
F60 EIP/DN T.O	The active connection with the Ethernet/IP Client has been lost.	Check the Ethernet/IP connection of the client (PLC, PC).
F61 NO INPUT V	The start command has been given while the drive is powered through the External 24V Power Supply.	Restore 3-Phase power supply to the drive before giving the start command.
F73 FLT COMP 1	The comparator 1 has been disabled.	Check the configuration of the comparator 1.
F74 FLT COMP 2	The comparator 2 has been disabled.	Check the configuration of the comparator 2.
F75 FLT COMP 3	The comparator 3 has been disabled.	Check the configuration of the comparator 3.
F76 SLAVE O.F	Failure of a slave.	Check the slave status.
F77OPT FIB TO	The fiber is broken.	Check wiring. Check the equipment status.
	One of the equipments of the network is turned off.	
	Improper connection.	
F78 TMP FREEMAQ	The temperature of the filter is very high.	Check the ventilation. Check the thermal contacts. Check the power contactor Check the wiring to the digital input configured as "FREMAQ FLT".

7. COMMONLY USED CONFIGURATIONS

7.1. Start / Stop Commands and Speed Reference by Keypad

7.1.1. Parameters Configuration

Parameter	Name / Description	Value
G1: Options Menu.		
4 LANG=ENGLISH	G1.4 / Language selection	ENGLISH
7 PROG = STANDARD	G1.7 / Program activation	STANDARD
G2: Motor Nameplate.		
1 MTR CURR=00.00A	G2.1 / Motor rated current	__ A (Set according to motor nameplate).
2 MTR VOLT=400V	G2.2 / Motor rated voltage	__ V (Set according to motor nameplate).
3 MTR PWR=00.0kW	G2.3 / Motor rated power	__ kW (Set according to motor nameplate).
4 MTR RPM=1450	G2.4 / Motor rpm	__ rpm (Set according to motor nameplate).
5 MTR PFA=0.84	G2.5 / Cosine Phi	__ (Set according to motor nameplate).
6 MTR FRQ=50Hz	G2.6 / Motor frequency	__ Hz (Set according to motor nameplate).
7 MTR COOL=63%	G2.7 / Motor cooling at zero speed	Use the following values as a reference: Submersible pumps and non-deflagrating motors → 5% Self-cool motor → 63% Force-cooled motor → 100%
G3: References.		
1 REF1 SPD=LOCAL	G3.1 / Speed reference source 1	LOCAL → Reference will be determined by keypad and is set in G3.3 'Local Speed Reference'.
3 LOCAL SPD=+100%	G3.3 / Local Speed Reference	100%
G4: Inputs – S4.1: Digital Inputs.		
1 CNTR0L MODE1=1	G4.1.1 / Main Control Mode	1 → LOCAL (Drive control is done by keypad).
3 RESET MODE=Y	G4.1.3 / Reset by keypad	Y → YES (Enables reset by keypad).

7.2. Start / Stop Commands by Terminals and Speed Reference by Analogue Input

7.2.1. Parameters Configuration

Parameter	Name / Description	Value
G1: Options Menu.		
4 LANG=ENGLISH	G1.4 / Language selection	ENGLISH
7 PROG = STANDARD	G1.7 / Program activation	STANDARD
G2: Motor Nameplate.		
1 MTR CURR=00.00A	G2.1 / Motor rated current	__ A (Set according to motor nameplate).
2 MTR VOLT=400V	G2.2 / Motor rated voltage	__ V (Set according to motor nameplate).
3 MTR PWR=00.0kW	G2.3 / Motor rated power	__ kW (Set according to motor nameplate).
4 MTR RPM=1485	G2.4 / Motor rpm	__ rpm (Set according to motor nameplate).
5 MTR PFA=0.85	G2.5 / Cosine Phi	__ (Set according to motor nameplate).
6 MTR FRQ=50Hz	G2.6 / Motor frequency	__ Hz (Set according to motor nameplate).
7 MTR COOL=63%	G2.7 / Motor cooling at zero speed	Use the following values as a reference: Submersible pumps and non-deflagrating motors → 5% Self-cool motor → 63% Force-cooled motor → 100%
G3: References.		
1 REF1 SPD=LOCAL	G3.1 / Speed reference source 1	LOCAL → Reference will be introduced by keypad and is set in G3.3 'Local Speed Reference'.
2 REF2 SPD=LOCAL	G3.2 / Speed reference source 2	AI1 → Reference will be introduced by Analogue Input 1.
3 LOCAL SPD=+100%	G3.3 / Local Speed Reference	+100%

Parameter	Name / Description	Value
G4: Inputs – S4.1: Digital Inputs.		
1 CTRL MODE1=2	G4.1.1 / Main Control Mode	2 → REMOTE (Drive control is done through control terminals).
4 DIGIT I MODE=1	G4.1.4 / Digital Inputs configuration selection	1 → ALL PROGRAMMABLE (all digital inputs can be individually configured by the user).
5 DIGITL IN 1=05	G4.1.5 / Multi-function Digital Input 1 configuration	05 → Start/Stop (Allows the start/stop command to be given by a switch).
6 DIGITL IN 2=15	G4.1.6 / Multi-function Digital Input 2 configuration	15 → Reference 2 (It allows selecting the alternative speed reference programmed in G3.2.)

7.2.2. Connections drawing

Terminals 1 and 2: start / stop command (NO status).
 Terminals 1 and 3: alternative reference command (NO status).

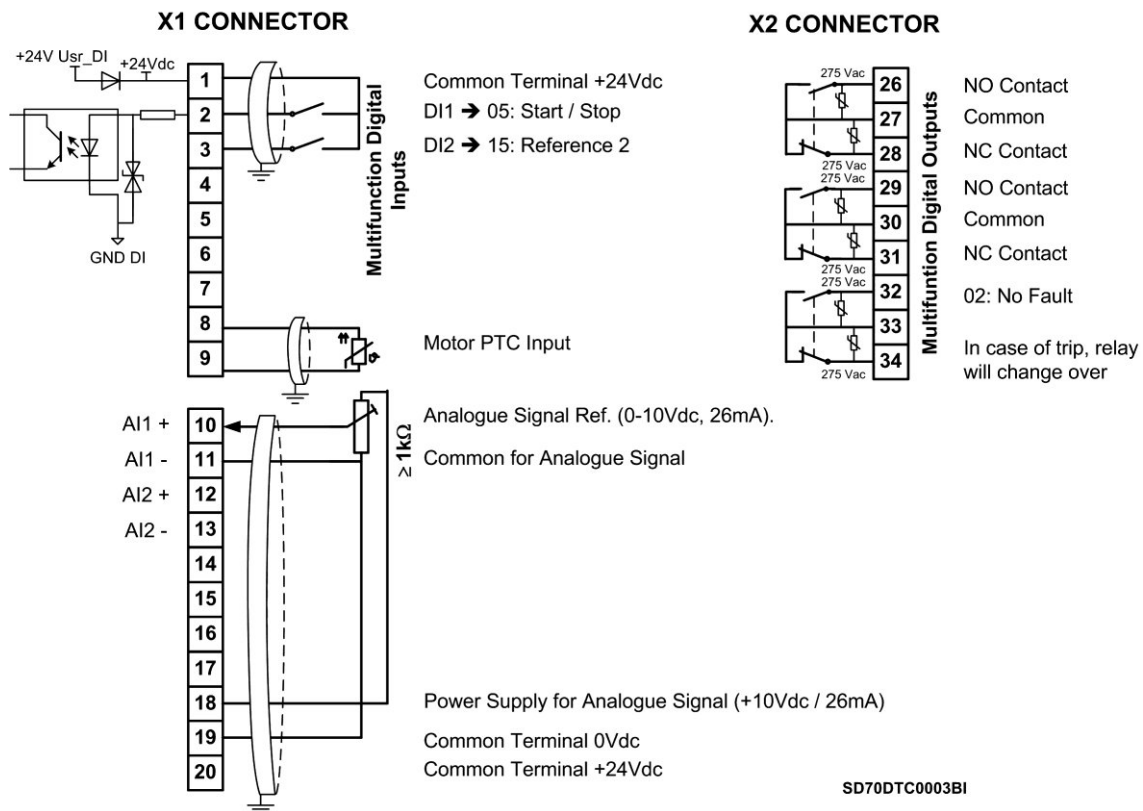

Figure 7.1 Start / Stop commands by terminals and speed reference by analogue input

Note: Use screened cables for the controls and connect screen to ground.

7.3. Start / Stop Commands by Terminals and Speed Reference by Motorized Potentiometer

7.3.1. Parameters Configuration

Parameter	Name / Description	Value
G1: Options Menu.		
4 LANG=ENGLISH	G1.4 / Language selection	ENGLISH
7 PROG = STANDARD	G1.7 / Program activation	STANDARD
G2: Motor Nameplate.		
1 MTR CURR=00.00A	G2.1 / Motor rated current	A (Set according to motor nameplate).
2 MTR VOLT=400V	G2.2 / Motor rated voltage	V (Set according to motor nameplate).
3 MTR PWR=00.0kW	G2.3 / Motor rated power	kW (Set according to motor nameplate).
4 MTR RPM=1485	G2.4 / Motor rpm	rpm (Set according to motor nameplate).
5 MTR PFA=0.85	G2.5 / Cosine Phi	(Set according to motor nameplate).
6 MTR FRQ=50Hz	G2.6 / Motor frequency	Hz (Set according to motor nameplate).
7 MTR COOL=63%	G2.7 / Motor cooling at zero speed	Use the following values as a reference: Submersible pumps and non-deflagrating motors → 5% Self-cool motor → 63% Force-cooled motor → 100%
G3: References.		
1 REF1 SPD=PMOT	G3.1 / Speed reference source 1	PMOT → Motorized potentiometer with or without reference memory.
G4: Inputs – S4.1: Digital Inputs.		
1 CNTROL MODE1=2	G4.1.1 / Main Control Mode	2 → REMOTE (Drive control is done through control terminals).
4 DIGIT I MODE=1	G4.1.4 / Digital Inputs configuration selection	4 → MOTORIZED POT (It assigns the function of up and down speed reference to two of the digital inputs. DI5 = Up (NO Contact) and DI6 = Down (NC Contact). Reference is memorized) 5 → ERASAB POT (As per above mode without memorizing the reference).
5 DIGITL IN 1=05	G4.1.5 / Multi-function Digital Input 1 configuration	05 → Start/Stop (Allows the start/stop command to be given by a switch).
G5: Inputs: Acceleration and Deceleration Ramps.		
7 PMT ACL1=1.0% / s	G5.7 / Ramp 1 of reference increase for motorized potentiometer	1.0% / s (Modify these ramps to tune operation). If the ramp is increased the speed reference response will be faster. If the ramp is decreased the speed reference response will be slower.
8 PMT DCL1=3.0% / s	G5.8 / Ramp 1 of reference decrease for motorized potentiometer	3.0% / s (Modify these ramps to tune operation). If the ramp is increased the speed reference response will be faster. If the ramp is decreased the speed reference response will be slower.

7.3.2. Connections Drawing

Terminals 1 and 2: start / stop command (NO status).
Terminals 1 and 6: up speed command (NO status).
Terminals 1 and 7: down speed command (NC status).

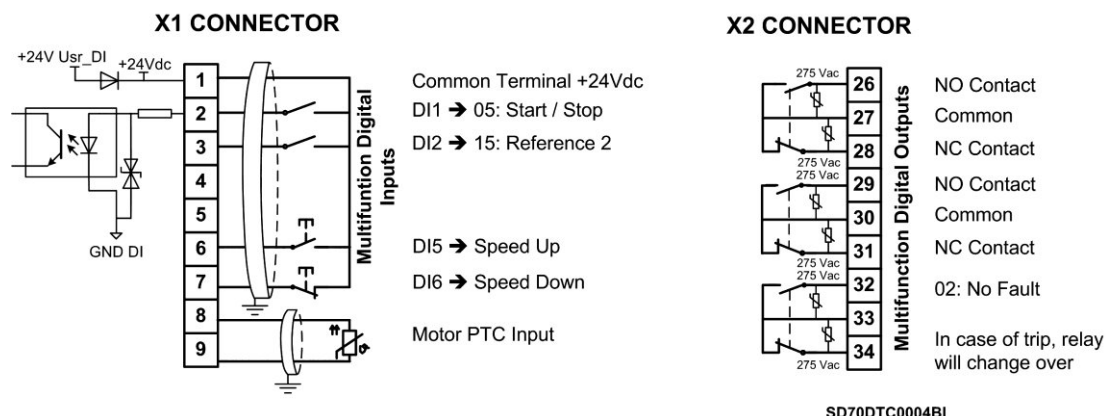

Figure 7.2 Start / Stop commands by terminals and speed reference by motorized potentiometer

Note: Use screened cables for the controls and connect the screen to the ground.

7.4. Start / Stop Commands by Terminals and Seven Speed References Selectable by Digital Inputs

7.4.1. Parameters Configuration

Parameter	Name / Description	Value
G1: Options Menu.		
4 LANG=ENGLISH	G1.4 / Language selection	ENGLISH
7 PROG = STANDARD	G1.7 / Program activation	STANDARD
G2: Motor Nameplate.		
1 MTR CURR=00.00A	G2.1 / Motor rated current	A (Set according to motor nameplate).
2 MTR VOLT=400V	G2.2 / Motor rated voltage	V (Set according to motor nameplate).
3 MTR PWR=00.0kW	G2.3 / Motor rated power	kW (Set according to motor nameplate).
4 MTR RPM=1485	G2.4 / Motor rpm	rpm (Set according to motor nameplate).
5 MTR PFA=0.85	G2.5 / Cosine Phi	(Set according to motor nameplate).
6 MTR FRQ=50Hz	G2.6 / Motor frequency	Hz (Set according to motor nameplate).
7 MTR COOL=63%	G2.7 / Motor cooling at zero speed	Use the following values as a reference: Submersible pumps and non-deflagrating motors → 5% Self-cool motor → 63% Force-cooled motor → 100%
G3: References.		
1 REF1 SPD=MREF	G3.1 / Speed reference source 1	MREF → Multiple speed references activated by digital inputs.
G4: Inputs – S4.1: Digital Inputs.		
1 CNTROL MODE1=2	G4.1.1 / Main Control Mode	2 → REMOTE (Drive control is done through control terminals).
4 DIGIT I MODE=3	G4.1.4 / Digital Inputs configuration selection	3 → MREF 3 WIRES (Automatically programs digital inputs 4, 5 and 6 as multiple speed references for up to 7 different values. The others digital inputs remain user configurable).
5 DIGITL IN 1=05	G4.1.5 / Multi-function Digital Input 1 configuration	05 → Start/Stop (Allows the start/stop command to be given by a switch).
G14: Multi-references.		
1 MREF 1=+10.0%	G14.1 / Multi-reference 1	+10.0% (Allows setting the setpoint 1 value for the drive. It should be set according to the application requirements).
2 MREF 2=+20.0%	G14.2 / Multi-reference 2	+20.0% (Allows setting the setpoint 2 value for the drive. It should be set according to the application requirements).
3 MREF 3=+30.0%	G14.3 / Multi-reference 3	+30.0% (Allows setting the setpoint 3 value for the drive. It should be set according to the application requirements).
4 MREF 4=+40.0%	G14.4 / Multi-reference 4	+40.0% (Allows setting the setpoint 4 value for the drive. It should be set according to the application requirements).
5 MREF 5=+50.0%	G14.5 / Multi-reference 5	+50.0% (Allows setting the setpoint 5 value for the drive. It should be set according to the application requirements).
6 MREF 6=+60.0%	G14.6 / Multi-reference 6	+60.0% (Allows setting the setpoint 6 value for the drive. It should be set according to the application requirements).
7 MREF 7=+70.0%	G14.7 / Multi-reference 7	+70.0% (Allows setting the setpoint 7 value for the drive. It should be set according to the application requirements).

7.4.2. Connections Drawing

Terminals 1 and 2: start / stop command (NO status).
 Terminals 1 and 5: multi-reference A (NO status).
 Terminals 1 and 6: multi-reference M (NO status).
 Terminals 1 and 7: multi-reference B (NO status).

SPEED	REF	Digital Input 4 Multi-reference-A	Digital Input 5 Multi-reference-M	Digital Input 6 Multi-reference-B
G14.1 = +10.0%	MREF1	0	0	X
G14.2 = +20.0%	MREF2	0	X	0
G14.3 = +30.0%	MREF3	0	X	X
G14.4 = +40.0%	MREF4	X	0	0
G14.5 = +50.0%	MREF5	X	0	X
G14.6 = +60.0%	MREF6	X	X	0
G14.7 = +70.0%	MREF7	X	X	X

Note: 0: Not active and X: Active.

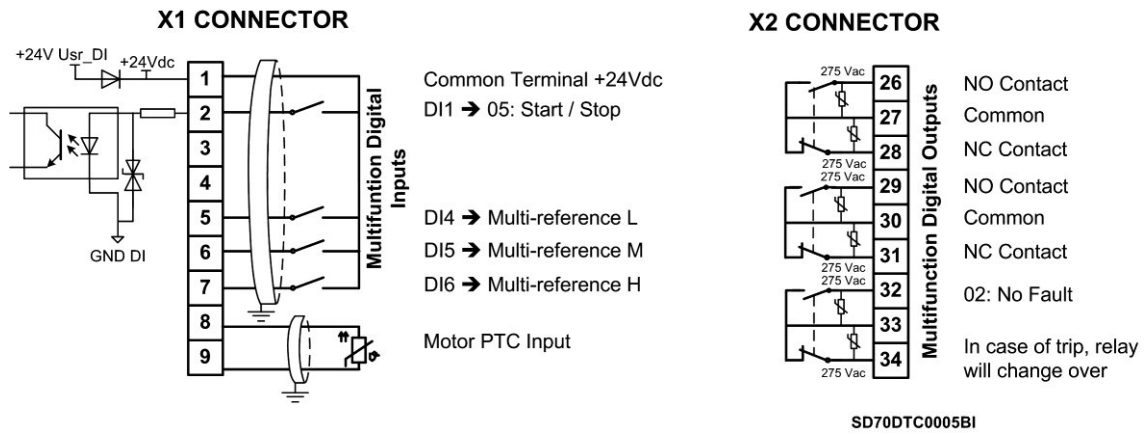

Figure 7.3 Start / Stop commands by terminals and 7 speeds by digital inputs

Note: Use screened cables for the controls and connect the screen to ground.

8. CONFIGURATION REGISTER

VARIABLE SPEED DRIVE: SD700.
 SERIAL N°: MODEL:
 APPLICATION:
 DATE:
 CUSTOMER:
 NOTES:

PARAMETERS	FACTORY SETTINGS	SETTING 1	SETTING 2
G1: Options Menu			
1 LOCK PARMTRS=0	0	_____	_____
2 PASSWORD_=OFF	OFF	_____	_____
3 PSW ERR=XXXX	XXXX	_____	_____
4 LANGUA=ESPAÑOL	ESPAÑOL	_____	_____
5 INITIALISE=0	0	_____	_____
6 SHORT Menu=NO	NO	_____	_____
7 PROG = STANDARD	STANDARD	_____	_____
11 FAN CTRL=FIXE	FIXE	_____	_____
12 RECT.BRIDGE=0	0	_____	_____

PARAMETERS	FACTORY SETTINGS	SETTING 1	SETTING 2
G2: Motor Nameplate Data			
1 MTR CUR=A MOTOR CURRENT	00.00A	_____	_____
2 MTR VOLT=400V MOTOR VOLTAGE	400V	_____	_____
3 MTR PWR=kW MOTOR POWER	00.00W	_____	_____
4 MTR RPM=1485 MOTOR SPEED (rpm)	1485	_____	_____
5 MTR PFA=0.85 MTR POWER FACTOR	0.85	_____	_____
6 MTR FRQ=50Hz MOTOR FREQUENCY	50Hz	_____	_____
7 MTR COOL=63% MOTOR COOLING	63%	_____	_____
G3: References			
1 REF1 SPD=LOCAL	LOCAL	_____	_____
2 REF2 SPD=LOCAL	LOCAL	_____	_____
3 LOCAL SPD=+100% LOCAL SPEED	+100%	_____	_____
4 REF1 TQ = LOCAL	LOCAL	_____	_____
5 REF2 TQ = NONE	NONE	_____	_____
6TQ= +100%	+100%	_____	_____
G4: Inputs – S4.1: Digital Inputs			
1 CNTROL MODE1=1	1	_____	_____
2 CNTROL MODE2=2	2	_____	_____
3 RESET MODE=Y	Y	_____	_____
4 DIGIT I MODE=1	1	_____	_____
5 DIGITL IN 1=06	06	_____	_____
6 DIGITL IN 2=00	00	_____	_____
7 DIGITL IN 3=00	00	_____	_____
8 DIGITL IN 4=00	00	_____	_____
9 DIGITL IN 5=00	00	_____	_____
10 DIGITL IN6=17	17	_____	_____
G4: Inputs – S4.2: Analogue Input 1			
1 SENSOR 1 ?=N	N	_____	_____
2 SENSOR 1= I/s	I/s	_____	_____
3 AIN1 FORMAT=V	V	_____	_____
4 INmin1=+0V AIN1 LOW RANGE	+0V	_____	_____
5 Smi1=+0.0I/s SENS1 LOW RANGE	+0.0I/s	_____	_____
6 INmax1=+10V AIN1 HIGH RANGE	+10V	_____	_____
7 Sma1=+10.0I/s SENS1 HIGH RANGE	+10.0I/s	_____	_____
8 SPD LO1=+0% SPD LO RNG AIN1	+0%	_____	_____

PARAMETERS	FACTORY SETTINGS	SETTING 1	SETTING 2
9 SPD HI1=+100% SPD HIG RNG AIN1	+100%	_____	_____
10 FB1 = +0.0l/s	+0.0l/s	_____	_____
11 FB1-SP = 0%	0%	_____	_____
12 FA1 = +10.0l/s	+10.0l/s	_____	_____
13 FA1-SP = 100%	100%	_____	_____
14 AIN1 LOSS=N	N	_____	_____
15 1_Z BAND=OFF AIN1 ZERO BAND	OFF	_____	_____
16 FILTER1=OFF AIN1 STABIL FILT	OFF	_____	_____
G4 Inputs – S4.3: Analogue Input 2			
1 SENSOR 2 ?=N	N	_____	_____
2 SENSOR 2=Bar	Bar	_____	_____
3 AIN2 FORMAT=mA	mA	_____	_____
4 INmin2=+4mA AIN2 LOW RANGE	+4mA	_____	_____
5 Smi2=+0.0Bar SENS2 LOW RANGE	+0.0Bar	_____	_____
6 INmax2=+20mA AIN2 HIGH RANGE	+20mA	_____	_____
7 Sma2=+10.0Bar SENS2 HIGH RANGE	+10.0Bar	_____	_____
8 SPD LO2=+0% SPD LO RNG AIN2	+0%	_____	_____
9 SPD HI2=+100% SPD HIG RNG AIN2	+100%	_____	_____
10 FB2 = +0.0Bar	+0.0Bar	_____	_____
11 FB2-SP = 0%	0%	_____	_____
12 FA2 = +10.0Bar	+10.0Bar	_____	_____
13 FA2-SP = 100%	100%	_____	_____
14 AIN2 LOSS=N	N	_____	_____
15 2_Z BAND=OFF AIN2 ZERO BAND	OFF	_____	_____
16 FILTER2=OFF AIN2 STABIL FILT	OFF	_____	_____
G4: Inputs – S4.4: Pulse Input			
1 Sensr U=l/m	l/m	_____	_____
2 Pls/s = 100 l/s LIQU AMOUNT/PULS	100l/s	_____	_____
3 M Rn=1000 l/s FLOW MAX RANGE	1000l/s	_____	_____
G4: Inputs – S4.6: Optic Fiber			
1 FIBER MODE = MAS	MAS	_____	_____
3.5 CONTROL = NONE	NONE	_____	_____
3.6 FAULT = N	N	_____	_____
3.7 SPIN STP = N	N	_____	_____
6.5 T/O F.O = 0	0	_____	_____

PARAMETERS	FACTORY SETTINGS	SETTING 1	SETTING 2
G5: Acceleration and Deceleration Ramps			
1 ACCE 1=5.0% / s INITIAL ACCEL	5.0% / s	_____	_____
2 DECEL 1=1.0% / s INITIAL DECEL	1.0% / s	_____	_____
3 ACCE 2=10.0% / s SECOND ACCELE	10.0% / s	_____	_____
4 DECEL 2=10.0% / s SECOND DECELE	10.0% / s	_____	_____
5 BRK ACC=OFF BREAKPOINT ACL	OFF	_____	_____
6 BRK DEC=OFF BREAKPOINT DCL	OFF	_____	_____
7 MP I1=1.0% / s MOTO POT INC1	1.0% / s	_____	_____
8 MP D1=3.0% / s MOTO POT DEC1	3.0% / s	_____	_____
9 MP I2=1.0% / s MOTO POT INC2	1.0% / s	_____	_____
10 MPD2=3.0% / s MOTO POT DEC2	3.0% / s	_____	_____
11 MPOTBRK=OFF MOTO POT BRKPOIN	OFF	_____	_____
12 SP FLT = 0.250s SMOOT SPD FILTER	0.250s	_____	_____
G6: PID Control			
1 SEL REF=MREF	MREF	_____	_____
2 PID LOC=+100.0% PID LOCAL SETPOI	+100.0%	_____	_____
3 SEL FBK=AI2	AI2	_____	_____
4 GAIN Kp=8.0 PID PROPORTIONAL	8.0	_____	_____
5 INTEGRAL = 0.1s PID INTEGRAL	0.0s	_____	_____
6 DIFFEREN = 0.0s PID DIFFERENTIAL	0.0s	_____	_____
7 INVERT PID=N	N	_____	_____
8 Filt FB = OFF	OFF	_____	_____
9 ERR PID = +0.0%	+0.0%	_____	_____
G7: Start / Stop Mode Configuration			
1 STOP 1 = RAMP	RAMP	_____	_____
2 STOP 2 = SPIN	SPIN	_____	_____
3 BRK STP 2 = OFF STP2 UNDER SPEED	OFF	_____	_____
4 START = RAMP	RAMP	_____	_____
5 START 2 = RAMP	RAMP	_____	_____
6 START DLY = OFF DELAY TO START	OFF	_____	_____
7 STOP DLY = OFF DELAY TO STOP	OFF	_____	_____
8 STP MIN SP = N	N	_____	_____
9 OFFdly = OFF DELAY AFTER STOP	OFF	_____	_____
10 RUN AFTR VFL = N	N	_____	_____
11 SPNstr B=OFF SPIN START TUNE	OFF	_____	_____

PARAMETERS	FACTORY SETTINGS	SETTING 1	SETTING 2
12 OFFdly2=OFF DELAY AFTER STP2	OFF	_____	_____
13 STR AFT RST=N	N	_____	_____
14 Dpwr OFF = OFF	OFF	_____	_____
15 MagnetT = OFF	OFF	_____	_____
16 DL SAR = 0.01s	0.01s	_____	_____
G8: Outputs – S8.1: Output Relays			
1 SEL RELAY 1=02	02	_____	_____
2 T R1 ON=0.0s R1 ACTIVAT DELAY	0.0s	_____	_____
3 T R1 OFF=0.0s R1 DEACTIV DELAY	0.0s	_____	_____
4 INVERT R1=N	N	_____	_____
5 SEL RELAY 2=03	03	_____	_____
6 T R2 ON=0.0s R2 ACTIVAT DELAY	0.0s	_____	_____
7 T R2 OFF=0.0s R2 DEACTIV DELAY	0.0s	_____	_____
8 INVERT R2=N	N	_____	_____
9 SEL RELAY 3=05	05	_____	_____
10 T R3 ON=0.0s R3 ACTIVAT DELAY	0.0s	_____	_____
11 T R3 OFF=0.0s R3 DEACTIV DELAY	0.0s	_____	_____
12 INVERT R3=N	N	_____	_____
13 CRAspdOF=+5.0% CRANE BRKoff SPD	+5.0%	_____	_____
34 Dig Out FB = DO1	DO1	_____	_____
35 DlyDoFB = 1.0s	1.0s	_____	_____
36 FAULT1 = OFF	OFF	_____	_____
37 FAULT2 = OFF	OFF	_____	_____
38 FAULT3 = OFF	OFF	_____	_____
39 FAULT4 = OFF	OFF	_____	_____
G8: Outputs – S8.2: Analogue Outputs			
1 ANLG OUT 1=01	01	_____	_____
2 FORMT 1=4-20 mA	mA	_____	_____
3 MIN1 RNG=0% MIN RANG ANAOUT1	+0%	_____	_____
4 MAX1 RNG=+100% MAX RANG ANAOUT1	+100%	_____	_____
5 FILTER 1=OFF FILTER ANAOUTPU1	OFF	_____	_____
6 ANLG OUT 2=02	02	_____	_____
7 FORMT 2=4-20 mA	4-20mA	_____	_____
8 MIN2 RNG=0% MIN RANG ANAOUT2	+0%	_____	_____

PARAMETERS	FACTORY SETTINGS	SETTING 1	SETTING 2
9 MAX2 RNG=+100%			
MAX RANG ANAOUT2	+100%	_____	_____
10 FILTER 2=OFF			
FILTER ANAOUTPU2	OFF	_____	_____
G9: Comparators – S9.1: Comparator 1			
1 COMP 1 SEL=00	00	_____	_____
2 COMP 1 TYPE=0	0	_____	_____
3 SP C1 ON=+100[%]			
C1 ACTIVAT LEVEL	+100[%]	_____	_____
4 LIM 2 C1=+100[%]			
C1 WINDOW LIMIT2	+100[%]	_____	_____
5 LIM 1 C1=+0[%]			
C1 WINDOW LIMIT1	+0[%]	_____	_____
6 T C1 ON=0.0s			
C1 ACTIVAT DELAY	0.0s	_____	_____
7 SP C1 OF=0[%]			
C1 DEACTIV LEVEL	+0[%]	_____	_____
8 T C1 OF=0.0s			
C1 DEACTIV DELAY	0.0s	_____	_____
9 SEL FUNT C1=00	00	_____	_____
G9: Comparators – S9.2: Comparator 2			
1 COMP 2 SEL=00	00	_____	_____
2 COMP 2 TYPE=0	0	_____	_____
3 SP C2 ON=+100[%]			
C2 ACTIVAT LEVEL	+100[%]	_____	_____
4 LIM 2 C2=+100[%]			
C2 WINDOW LIMIT2	+100[%]	_____	_____
5 LIM 1 C2=+0[%]			
C2 WINDOW LIMIT1	+0[%]	_____	_____
6 T C2 ON=0.0s			
C2 ACTIVAT DELAY	0.0s	_____	_____
7 SP C2 OF=0[%]			
C2 DEACTIV LEVEL	+0[%]	_____	_____
8 T C2 OF=0.0s			
C2 DEACTIV DELAY	0.0s	_____	_____
9 SEL FUNT C2=00	00	_____	_____
G9: Comparators – S9.3: Comparator 3			
1 COMP 3 SEL=00	00	_____	_____
2 COM 3 TYPE=0	0	_____	_____
3 SP C3 ON=+100[%]			
C3 ACTIVAT LEVEL	+100[%]	_____	_____
4 LIM 2 C3=+100[%]			
C3 WINDOW LIMIT2	+100[%]	_____	_____
5 LIM 1 C3=+0[%]			
C3 WINDOW LIMIT1	+0[%]	_____	_____
6 T C3 ON=0.0s			
C3 ACTIVAT DELAY	0.0s	_____	_____
7 SP C3 OF=0[%]			
C3 DEACTIV LEVEL	+0[%]	_____	_____
8 T C3 OF=0.0s			
C3 DEACTIV DELAY	0.0s	_____	_____
9 SEL FUNT C3=00	00	_____	_____
G10: Limits			
1 MIN1 SP=+0%			
SPEED MIN LIMIT1	0%	_____	_____
2 MAX1 SP=+100%			
SPEED MAX LIMIT1	+100%	_____	_____

PARAMETERS	FACTORY SETTINGS	SETTING 1	SETTING 2
3 MIN2 SP=-100% SPEED MIN LIMIT2	-100%	_____	_____
4 MAX2 SP=+100% SPEED MAX LIMIT2	+100%	_____	_____
5 I LIMIT= ___ A MAX CURRENT	___ A	_____	_____
6 I LIM TO = OFF TIMEOUT MAX CURRE	OFF	_____	_____
7 I. MAX2= ___ A MAX CURRENT 2	___ A	_____	_____
8 MI2 brSP=OFF MAX CURR BRK SPD	OFF	_____	_____
9 MAX TOR=+150% MAX TORQUE	+150%	_____	_____
10 T LIM TO=OFF TIMEOUT MAX TORQ	OFF	_____	_____
11 INVERSION?=N	N	_____	_____
12 ILIM RGN=OFF CURR.LIMIT.RGN	OFF	_____	_____
13 Ilim_rgnTO=OFF ILim.Regen.Tmout	OFF	_____	_____
14 T/I LIM SP = N	N	_____	_____
15 Rg TQ L = 150%	150%	_____	_____
G11: Protections			
1 SP LIM_TO=OFF TMAX LIMITIN SPD	OFF	_____	_____
2 STOP TO=OFF TIMEOUT STOPPING	OFF	_____	_____
3 GND I LIMIT=10% GND CURR MAX LEV	10%	_____	_____
4 LOW VOLT=360V LO INPUT VOLTAGE	360V	_____	_____
5 LOW V TO=5s LO INP VOL TIMEO	5s	_____	_____
6 HIGH VOLT=500V HI INPUT VOLTAGE	500V	_____	_____
7 HI V TO=5s HI INP VOL TIMEO	5.0s	_____	_____
8 Dasy VO = OFF VOU_T asyTRIP DLY	OFF	_____	_____
9 LOW V BHV=1	1	_____	_____
10 PTC EXT ?=N	N	_____	_____
11 PUMP OV=20.0A PUMP OVERLOAD LV	20.0A	_____	_____
12 PMovl FIL=OFF PMP OVL FILTER	OFF	_____	_____
13 Povi DLY=OFF PMP OVERLOAD DLY	OFF	_____	_____
14 UNDERLOAD=N	N	_____	_____
15 ULD CUR= ___ A UNDERLOAD CURREN	___ A	_____	_____
16 ULD SPD=+100% UNDERLOAD SPEED	+100%	_____	_____
17 ULD DELY=10s UNDERLOAD DELAY	10s	_____	_____
18 DEC.SPdly=OFF DECREM.SP.DELAY	OFF	_____	_____
19 Sp.SRCH.I =10% SPD.SEARCH INCR.	10%	_____	_____
21 MSpeedT = OFF	OFF	_____	_____
22 Dasy IO = 5.0s	5.0s	_____	_____

PARAMETERS	FACTORY SETTINGS	SETTING 1	SETTING 2
G12: Auto Reset			
1 AUTORESET=N	N	_____	_____
2 ATTEMP NUMBR=1 MAX ATTEMPT NUMB	1	_____	_____
3 R STR DEL=5s TIME BEFORE RESET	5s	_____	_____
4 RS COUNT=15min AUTORESET TIMEOUT	15min	_____	_____
5 F1 AUTO RST=0	0	_____	_____
6 F2 AUTO RST=0	0	_____	_____
7 F3 AUTO RST=0	0	_____	_____
8 F4 AUTO RST=0	0	_____	_____
G13: Fault History			
1 F0 NO FAULT LAST FAULT=FX	-	_____	_____
2 F0 NO FAULT FIFTH FAULT=FX	-	_____	_____
3 F0 NO FAULT FOURTH FAULT=FX	-	_____	_____
4 F0 NO FAULT THIRD FAULT=FX	-	_____	_____
5 F0 NO FAULT SECOND FAULT=FX	-	_____	_____
6 F0 NO FAULT FIRST FAULT=FX	-	_____	_____
7 CLEAR FAULTS=N	N	_____	_____
G14: Multi-references			
1 MREF 1=+10.0% MULTI-REFERENCE1	+10.0%	_____	_____
2 MREF 2=+20.0% MULTI-REFERENCE2	+20.0%	_____	_____
3 MREF 3=+30.0% MULTI-REFERENCE3	+30.0%	_____	_____
4 MREF 4=+40.0% MULTI-REFERENCE4	+40.0%	_____	_____
5 MREF 5=+50.0% MULTI-REFERENCE5	+50.0%	_____	_____
6 MREF 6=+60.0% MULTI-REFERENCE6	+60.0%	_____	_____
7 MREF 7=+70.0% MULTI-REFERENCE7	+70.0%	_____	_____
G15: Inch Speeds			
1 INCH1=+0.00% INCH SPEED 1	+0.00%	_____	_____
2 INCH2=+0.00% INCH SPEED 2	+0.00%	_____	_____
3 INCH3=+0.00% INCH SPEED 3	+0.00%	_____	_____
G16: Skip Frequencies			
1 SKIP 1=+0.0% SKIP FREQUENCY 1	+0.0%	_____	_____
2 SKIP 2=+0.0% SKIP FREQUENCY 2	+0.0%	_____	_____
3 SKIP BAND=OFF OFFSET BAND	OFF	_____	_____
G17: Brake			
1 T DC BRAKE=OFF DC BRAKING TIME	OFF	_____	_____
2 DC CURR=0% DC CURRENT LEVEL	0%	_____	_____

PARAMETERS	FACTORY SETTINGS	SETTING 1	SETTING 2
3 DC VOLTS=0.0% DC BR VOLT LEVEL	0.0%	_____	_____
4 I HEATING=OFF Idc HEATING	OFF	_____	_____
5 DYN BRAK=N	N	_____	_____
G18: Encoder			
0 ENCODER = N	N	_____	_____
1 PULSES = 1024	1024	_____	_____
2 TYPE = DIFF	DIFF	_____	_____
3 ENCOD FILTER = N	N	_____	_____
G19: Fine Tuning – S19.1: IGBT Control			
1 TYPE CRTL=V/Hz	V / Hz	_____	_____
2 VECTOR CTR = PMC	PMC	_____	_____
3 PMC = OL SP	OL SP	_____	_____
4 AVC = CL SP	CL SP	_____	_____
5 FRQ=4000Hz MODULAT FREQUENC	4000	_____	_____
6 PEWAVE=Y	Y	_____	_____
8 Autotune=N	N	_____	_____
9 OVERMODULATIO=N	N	_____	_____
G19: Fine Tuning – S19.2: MTR Load			
1 MIN FLUX = 100% MINIMUM FLUX	100%	_____	_____
3 V BOOST = 0.0% BOOST VOLTAGE	0.0%	_____	_____
4 SLIP COMPENS=N	N	_____	_____
5 DAMP.gain=0.0%	0.0%	_____	_____
7 I SLIP=2.0% I SLIP COMPENSAT	2.0%	_____	_____
9 STR FRQ = 0.0% START FREQUENCY	0.0%	_____	_____
11 DAMP.ref=3% DAMPINGreferec	3%	_____	_____
13 CTR Vbus=800 REGEN BUS VOLT	800	_____	_____
G19: Fine Tuning – S19.3: MTR Model			
1 R STATOR=0.9% STATOR RESISTOR	0.9%	_____	_____
2 R. RTR = 0%	0.0%	_____	_____
3 Lm = 40%	40%	_____	_____
4 L.I = 0%	0.0%	_____	_____
5 FL WEAK = 90%	90%	_____	_____
G19: Fine Tuning – S19.4: Control PID			
1 Kp Sp = 95%	95%	_____	_____
2 Ki Sp = 95%	95%	_____	_____

PARAMETERS	FACTORY SETTINGS	SETTING 1	SETTING 2
3 Kp Tq = 95%	95%	_____	_____
4 Ki Tq = 95%	95%	_____	_____
5 Kp I = 95%	95%	_____	_____
6 Ki I = 15%	15%	_____	_____
9 Flux tune = 2.0%	2.0%	_____	_____
G20: Communication Buses – S20.0: Communications Control			
1 COM. CONTROL=0	0	_____	_____
G20: Communication Buses – S20.1: Modbus RTU			
1 COMMS T/O=OFF COMMS TIMEOUT	OFF	_____	_____
2 COMM ADDR=10 COMM ADDRESS	10	_____	_____
3 BAUDS=9600	9600	_____	_____
4 PARITY=NONE	NONE	_____	_____
G20: Communication Buses – S20.2: PROFIBUS			
1 NODE ADDR=10 NODE ADDRESS	10	_____	_____
G20: Communication Buses – S20.3: CANOPEN			
1 CO NODEID=0	0	_____	_____
2 CO BAUD=1Mbps	1Mbps	_____	_____
3 CO REF sp=+0.0%	+0.0%	_____	_____
G20: Communication Buses – S20.4: DEVICENET			
1 DN MACID=0	0°	_____	_____
2 DNBAud=500kbps	500kbps	_____	_____
3 CONTROL MODE=0	0	_____	_____
4 REFEREN MODE=0	0	_____	_____
5 FAULT MODE = PE BEHV	PE BEHV	_____	_____
6 ASM IN=70	70°	_____	_____
7 ASM- OUT=20	20°	_____	_____
8 DNst=UNUSED	UNUSED	_____	_____
G20: Communication Buses – S20.5: OFC			
1 B/R F.O = 1 Mbps	1 Mbps	_____	_____
G20: Communication Buses – S20.6: Registers			
01 Reg01 = 40001	40001	_____	_____
02 Reg02 = 40001	40001	_____	_____
03 Reg03 = 40001	40001	_____	_____
04 Reg04 = 40001	40001	_____	_____
05 Reg05 = 40001	40001	_____	_____
06 Reg06 = 40001	40001	_____	_____
07 Reg07 = 40001	40001	_____	_____

PARAMETERS	FACTORY SETTINGS	SETTING 1	SETTING 2
08 Reg08 = 40001	40001	_____	_____
09 Reg09 = 40001	40001	_____	_____
10 Reg10 = 40001	40001	_____	_____
11 Reg11 = 40001	40001	_____	_____
12 Reg12 = 40001	40001	_____	_____
13 Reg13 = 40001	40001	_____	_____
14 Reg14 = 40001	40001	_____	_____
15 Reg15 = 40001	40001	_____	_____
16 Reg16 = 40001	40001	_____	_____
17 Reg17 = 40001	40001	_____	_____
18 Reg18 = 40001	40001	_____	_____
19 Reg19 = 40001	40001	_____	_____
20 Reg20 = 40001	40001	_____	_____
21 Reg21 = 40001	40001	_____	_____
22 Reg22 = 40001	40001	_____	_____
23 Reg23 = 40001	40001	_____	_____
24 Reg24 = 40001	40001	_____	_____
25 Reg25 = 4001	40001	_____	_____
26 Reg26 = 40001	40001	_____	_____
27 Reg27 = 40001	40001	_____	_____
28 Reg28 = 40001	40001	_____	_____
29 Reg29 = 40001	40001	_____	_____
30 Reg30 = 40001	40001	_____	_____
31 Reg31 = 40001	40001	_____	_____
G21: Networks – S21.1: ETHERNET			
1 AUTOMATIC IP=Y	Y	_____	_____
lxxx.yyy.zzz.hhh	-	_____	_____
Sxxx.yyy.zzz.hhh	-	_____	_____
Gxxx.yyy.zzz.hhh	-	_____	_____
2 IP MANU. A=192	192	_____	_____
3 IP MANU. B=168	168	_____	_____
4 IP MANU. C=1	1	_____	_____
5 IP MANU. D=143	143	_____	_____
6 SUBNET A=255	255	_____	_____

PARAMETERS	FACTORY SETTINGS	SETTING 1	SETTING 2
7 SUBNET B=255	255	_____	_____
8 SUBNET C=255	255	_____	_____
9 SUBNET D=0	0	_____	_____
10 GATEWAY A=0	0	_____	_____
11 GATEWAY B=0	0	_____	_____
12 GATEWAY C=0	0	_____	_____
13 GATEWAY D=0	0	_____	_____
14 MAC A=0	0	_____	_____
15 MAC B=80	80	_____	_____
16 MAC C=194	194	_____	_____
17 MAC D=114	114	_____	_____
18 MAC E=X	X	_____	_____
19 MAC F=Y	Y	_____	_____
G21: Networks – S21.2: MODBUS TCP			
1 MIPtout=OFF			
MODBUS TCP TOUT	OFF	_____	_____
G21: Networks – S21.3: ETHER./IP			
1 CONTROL MODE=0	0	_____	_____
2 REFEREN.MODE=0	0	_____	_____
3 FAULT MODE = PE BEHV	PE BEHN	_____	_____



POWER ELECTRONICS®

www.powerelectronics.es | www.power-electronics.com

24 Hours Technical Assistance 365 days a year

+34 96 136 65 57

HEADQUARTER • VALENCIA • SPAIN	
C/ Leonardo da Vinci, 24 – 26 • Parque Tecnológico • 46980 – PATERNA • VALENCIA • ESPAÑA Tel. 902 40 20 70 • Tel. (+34) 96 136 65 57 • Fax (+34) 96 131 82 01	
BRANCHES	
CATALONIA	BARCELONA • Avda. de la Ferrería, 86-88 • 08110 • MONTCADA I REIXAC Tel. (+34) 96 136 65 57 • Fax (+34) 93 564 47 52
	LLEIDA • C/ Terrasa, 13 • Bajo • 25005 • LLEIDA Tel. (+34) 97 372 59 52 • Fax (+34) 97 372 59 52
CANARY ISLANDS	LAS PALMAS • C/ Juan de la Cierva, 4 • 35200 • TELDE Tel. (+34) 928 68 26 47 • Fax (+34) 928 68 26 47
LEVANT	VALENCIA • Leonardo da Vinci, 24-26 • 46980 • PATERNA Tel. (+34) 96 136 65 57 • Fax (+34) 96 131 82 01
	CASTELLÓN • C/ Juan Bautista Poeta • 2º Piso • Puerta 4 • 12006 • CASTELLÓN Tel. (+34) 96 434 03 78 • Tel. (+34) 96 136 65 57 • Fax (+34) 96 434 14 95
	MURCIA • Pol. Residencial Santa Ana • Avda. Venecia, 17 • 30319 • CARTAGENA Tel. (+34) 96 853 51 94 • Fax (+34) 96 812 66 23
NORTH	VIZCAYA • Parque de Actividades • Empresariales Asuarán • Edificio Asúa, 1º B • Ctra. Bilbao • Plencia • 48950 • ERANDIO • Tel. (+34) 96 136 65 57 • Fax (+34) 94 431 79 08
CENTRE	MADRID • Avda. Rey Juan Carlos I, 98, 4º C • 28916 • LEGANÉS Tel. (+34) 96 136 65 57 • Fax (+34) 91 687 53 84
SOUTH	SEVILLA • C/ Averroes, 6 • Edificio Eurosevilla • 41020 • SEVILLA Tel. (+34) 96 136 65 57 • Fax (+34) 95 451 57 73
INTERNATIONAL SUBSIDIARIES	
GERMANY	Power Electronics Deutschland GmbH • Dieselstrasse, 77 • D-90441 • NÜRNBERG • GERMANY Tel. (+49) 911 99 43 99 0 • Fax (+49) 911 99 43 99 8
AUSTRALIA	Power Electronics Australia Pty Ltd • U6, 30-34 Octal St, Yatala, • BRISBANE, QUEENSLAND 4207 • P.O. Box 3166, Browns Plains, Queensland 4118 • AUSTRALIA Tel. (+61) 7 3386 1993 • Fax (+61) 7 3386 1997
BRAZIL	Power Electronics Brazil Ltda • Av. Guido Caloi, 1985-Galpão 09 • CEP 05802-140 • SÃO PAULO • BRASIL Tel. (+55) 11 5891 9612 • Tel. (+55) 11 5891 9762
CHILE	Power Electronics Chile Ltda • Los Productores # 4439 – Huechuraba • SANTIAGO • CHILE Tel. (+56) (2) 244 0308 • 0327 • 0335 • Fax (+56) (2) 244 0395
	Oficina Petronila # 246, Casa 19 • ANTOFAGASTA • CHILE Tel. (+56) (55) 793 965
CHINA	Power Electronics Beijing • Room 509, Yiheng Building • No 28 East Road, Beisanhuan • 100013, Chaoyang District • BEIJING • R.P. CHINA Tel. (+86 10) 6437 9197 • Fax (+86 10) 6437 9181
	Power Electronics Asia Ltd • 20/F Winbase Centre • 208 Queen's Road Central • HONG KONG • R.P. CHINA
KOREA	Power Electronics Asia HQ Co • Room #305, SK Hub Primo Building • 953-1, Dokok-dong, Gangnam-gu • 135-270 • SEOUL • KOREA Tel. (+82) 2 3462 4656 • Fax (+82) 2 3462 4657
INDIA	Power Electronics India • No 26 3rd Cross, • Vishwanathapuram • 625014 • MADURAI Tel. (+91) 452 434 7348 • Fax (+91) 452 434 7348
ITALY	Power Electronics Italia Srl • Piazzale Cadorna, 6 • 20123 • MILANO • ITALIA Tel. (+39) 347 39 74 792
JAPAN	Power Electronics Japan KK • Nishi-Shinbashi 2-17-2 • HF Toranomom Bldg. 5F • 105-0003 • Minato-Ku • Tokyo Tel. (+81) 03 6355 8911 • Fax (+81) 03 3436 5465 • Email: salesjapan@power-electronics.com
MEXICO	P.E. Internacional Mexico S de RL • Calle Cerrada José Vasconcelos, 9 • Colonia Tlalnepantla Centro • Tlalnepantla de Baz • CP 54000 • MEXICO DF Tel. (+52) 55 5390 8818 • Tel. (+52) 55 5390 8363 • Tel. (+52) 55 5390 8195
NEW ZEALAND	Power Electronics Nueva Zelanda Ltd • 12A Opawa Road, Waltham • CHRISTCHURCH 8023 • P.O. Box 1269 CHRISTCHURCH 8140 Tel. (+64 3) 379 98 26 • Fax. (+64 3) 379 98 27
UNITED STATES OF AMERICA	Power Electronics USA Inc. • 505 Montgomery Street, 11th Floor • San Francisco • CA 94111 • UNITED STATES OF AMERICA Tel: (415) 874-3668 • Fax: (415) 874-3001 • Mov: (415) 376-1471 • Email: sales@power-electronics.us



www.power-electronics.com